



FHSCP-UNV-12W-L-SD



Important Safety Instructions

When using electrical equipment and this lighting device basic safety precaution should be followed at all times including but not limited to the following:

PLEASE READ CAREFULLY AND FOLLOW ALL INSTRUCTIONS FOR YOUR OWN SAFETY

Important: An un-switched AC power source of 120VAC to 277VAC is required.

Important: Double insulation used between the supply and battery circuit.

Important: Intermittent re-charging circuit.

Important: The recharging device remains safe after abnormal operating condition.

CAUTION: Do not let power supply cords touch hot surfaces.

CAUTION: Do not mount near gas or electric heaters.

CAUTION: Do not use outdoors.

CAUTION: This equipment has not been investigated for use in an air-handling fixture, it is not suitable in a heated air outlet.

CAUTION: Sealed unit. Battery not replaceable. Replace entire unit when necessary.

Do not use this emergency driver with accessory equipment other than recommended by manufacturer; failure to follow this may cause an unsafe condition. Servicing should only be performed by qualified service personnel.

De-energize before opening.

Do not use this emergency driver for other than intended use.

Equipment should be mounted in locations and at heights where it will not readily be subjected to tampering by unauthorized personnel.

Use with grounded, UL Listed, dry or damp location rated fixtures.

Important: Indicator (LED light) illuminated indicates battery in charge mode when AC power is applied.

CAUTION: Device has to be checked and re-activated to keep emergency function after installation.

It is recommended and required by applicable code to test emergency function to ensure proper operation of the system; push the test switch for sixty (60) seconds every 30 days to ensure the emergency driver is functioning as by illuminating the LED light source. Conduct a ninety minute (90) discharge test one time (1) per year; LED light source should be illuminated for a minimum of ninety minutes (90).

ASSEMBLY and FIELD INSTALLATION WIRING: WARNING: AC power must be off before proceeding with assembly or installation of emergency driver.

TESTING SYSTEM: The emergency battery requires a charge minimum of one (1) hour before testing the circuit. A full charge requires Twenty-four (24) hours.

IMPORTANT: In order to maintain proper operation and warranty coverage, the battery must be recharged once per year prior to installation.

WARNING: Install in accordance with the national and local electrical code. Disconnect power before servicing. Driver must be grounded.

ATTENTION: L'installation doit être conforme aux normes du code national électrique. Débranchez l'alimentation avant l'entretien. Pilote doivent être mis à la terre.

Fulham Head Quarters:
Fulham Co., Inc
12705 South Van Ness Ave.
Hawthorne, CA90250

Manufacturer:
North China
Fulham Electronic Co. Ltd.
No. 9 heying Road, Nanshao Zhen Changping Science and technology Park, Beijing, P.R. China

SAVE THESE INSTRUCTIONS

FHSCP-UNV-12W-L-SD



RoHS
COMPLIANT



Wiring Diagram

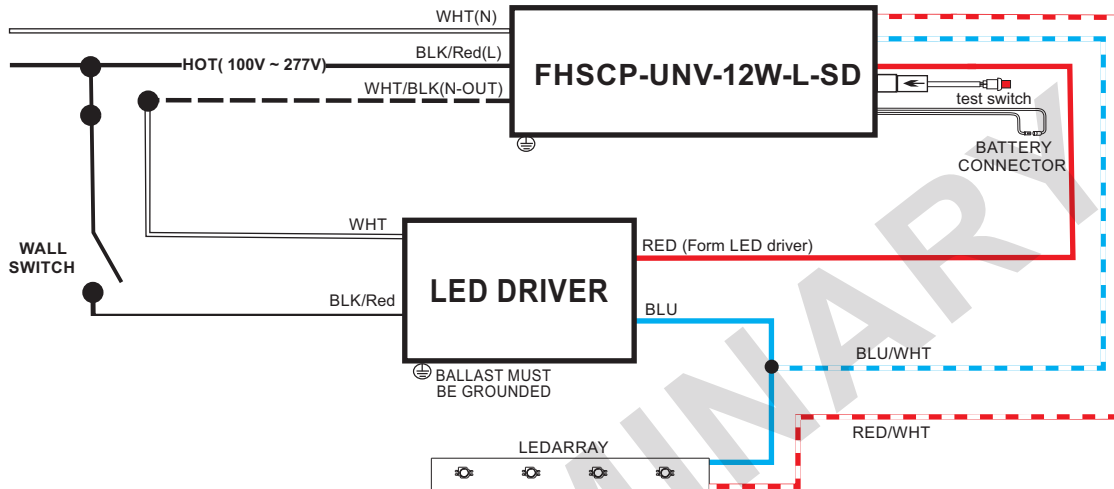

Wiring Diagram (Emergency Only)

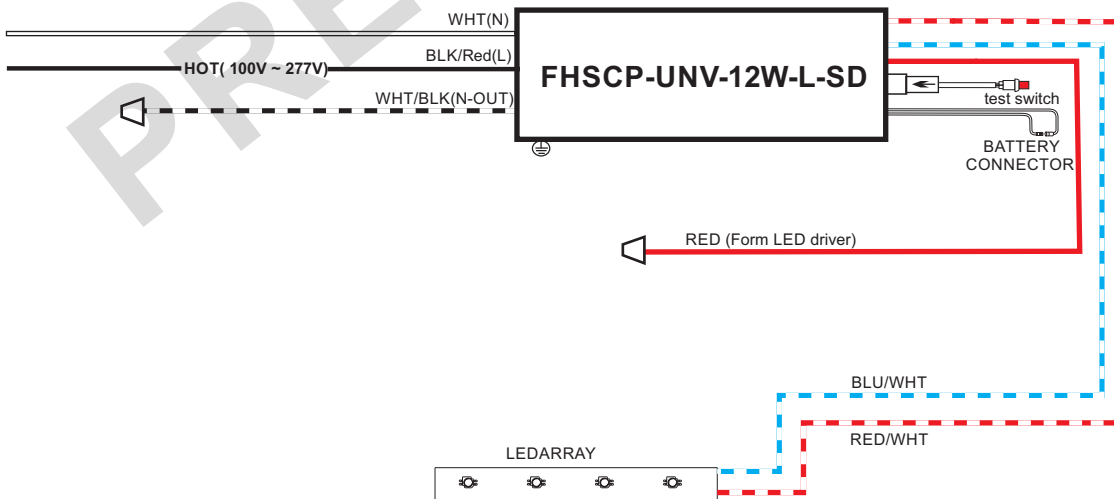

FHSCP-UNV-12W-L-SD

Accessories

Test switch wire

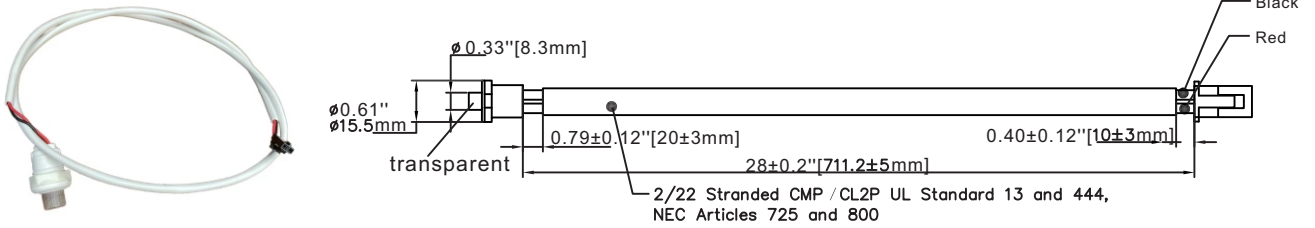

Wall Plate: FHSWLPWH



Wall plate and screw color:
white with black lettering

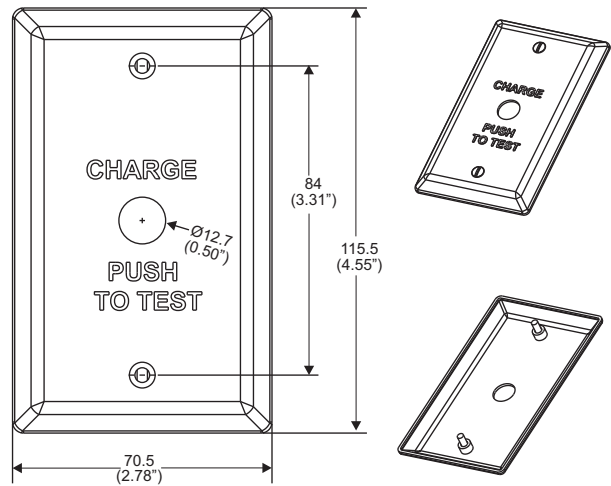

1. "Charge push to Test" plate
2. (2) 6-32 x 1/2" LG mounting screws

FHSCP-UNV-12W-L-SD



Guideline on calculating emergency illumination level

The purpose of this guideline is to identify the illumination level of the LED luminaire when used with Fulham's FHSCP-UNV-12W-L-SD LED emergency driver. The path of egress illumination level during emergency operation is determined by types of luminaires, Luminaire Efficacy, Luminaire Mounting Height, Emergency Power and some other effects in real application.

Step 1: Select an LED Luminaire, and make sure the LED light source is electrically compatible with Fulham's LED emergency driver. Get the Light Distribution data (usually an .ies file) and Rated Efficacy data (lumen per watt) from luminaire supplier.

If the luminaire is Design Lights Consortium TM (DLC) compliant, you can also get the efficacy information from DLC website.

- Open DLC Qualified Product List(QPL) database search page: <https://www.designlights.org/search/>
- Searching keywords by model, brand name or manufacturer for the luminaire used.
- Find the "Efficacy" data listed on website or calculated by dividing "Light output" by "Wattage", the efficacy value should be shown in lumen per watt (lm/W).

If the luminaire is ENERGY STAR compliant, you can also get the luminaire efficacy information from ENERGY STAR website.

- Open ENERGY STAR certified Light Fixtures database search page: <https://www.energystar.gov/productfinder/product/certified-light-fixtures/results>
- Searching keywords by model, brand name or manufacturer for the luminaire used.
- Find the "Energy Efficiency" data listed on website. If it is showed as "Measured at the Source", please contact with luminaire supplier for additional light loss for this light source inside the fixture. The value should be shown in lumen per watt (lm/W).

Step 2: Determine the Emergency Power and calculate the Emergency Light Output.

FHSCP-UNV-12W-L-SD is programmable output; setting a proper Emergency Power is vital to achieve desired illumination.

Emergency Light Output is equal to the Emergency Power multiply by luminaire efficacy. For example, if the luminaire is 120lm/W and in 3W emergency operation, the total Emergency Light Output is 120lm/W 3W = 360lm.

Step 3: Use industry lighting design software to calculate the illumination level according to the luminaire layout in room, luminaire mounting height, the original .ies file and Emergency Light Output calculated above. If the illumination level cannot meet life safety codes, go back to Step 2 to use a higher Emergency Power or go back to Step1 to select a higher efficacy luminaire or use more luminaires in the room.

Fulham's FHSCP-UNV-12W-L-SD LED emergency driver is compliant with UL924 standard, according to UL test data, Table 1 below give basic indication to determine the min. Emergency Power and Luminaire Max. Mounting Height for 1 foot-candle illumination based on a single luminaire with typical Lambertian distribution. It is the light designer / construction contractor's responsibility to validate the real illumination level on site, to assure the emergency light illumination level is in accordance with the requirement of Federal, state and local municipal codes. It may differ from the theoretical calculations or simulations on a computer.

Table 1. Max. Mounting Height vs. Luminaire Efficacy

Luminaire Efficacy (lm/W)	Max. Mounting Height for 1fc
	EM 12W
175	26.2 ft

FHSCP-UNV-12W-L-SD



SELF-DIAGNOSTIC INSTRUCTIONS / OPERATION:

If the self-diagnostic feature is enabled:

The emergency LED driver will conduct a self-check for sixty(60)seconds every thirty(30)days; and ninety(90) minutes self-check every 12 months. After every self-check the LED indicator light will indicate a status signal. Check indicator status chart above to diagnose the status signal.

***Self-Diagnostic feature is factory enabled**

TEST SWITCH INDICATOR STATUS:

LED Indicators Status	EM Driver Status/Mode
● Solid Green	System OK/AC OK.
● Flashing (0.1s on/3s off)	Normal working in EM mode. (Including Self-test/self-diagnostic)
● Flashing (1s on/1s off)	Self-diagnose process ongoing.
● Flashing (2s on/0.5s off)	Self-diagnose enabled
● Flashing (0.5s on/2s off)	Self-diagnose disabled
● Flashing (4s on/1s off)	Battery PACK not found.(Including Self-test/self-diagnostic)
● Flashing (1s on/1s off)	Battery PACK fault. (Including Self-test/self-diagnostic)
● Solid Red	Over voltage protection. (Including Self-test/self-diagnostic)
● Solid Red	Over current protection. (Including Self-test/self-diagnostic)
● Flashing (1s on/7s off)	Over temperature protection.(Including Self-test/self-diagnostic)
● Flashing (0.1s on/3s off)	Self-diagnose process current fault or Battery voltage <87.5%.

Test Switch Operations:

EM Test: Press and hold test button (1s) to enter EM mode for testing in normal AC powered.
Long press (10s) exit emergency mode.

Instructions for self-diagnostics key settings:

1. Set Self-Diagnostic Enable/Disable: Quickly press the test press once, then release and hold the test button for two seconds. Flashing 2s ON/0.5s OFF three times in a row means "Enabled", and flashing 0.5s ON/2s OFF three times in a row means "Disabled".
2. Query Self-Diagnostic Status: Quickly click twice within 2 seconds, the indicator flashes, 2s ON/0.5s OFF flashes three times in a row to indicate that it is "enabled", and 0.5s ON/2s OFF flashes three times in a row to indicate that it is disabled.

How to Enable and Disable Self-Diagnostic Status:

Press and hold the test button for one second, then release, and press and hold the test button for 2 seconds.