

## 60 to 120 W Constant Current LED Drivers with Tri-Mode Dimming™ (TRIAC, ELV & 0-10 V)

Input Voltage	Max. Output Power	Output Voltage	Output Current	Efficiency	Max. Case Temperature	THD	Power Factor	Dimming Method	Dimming Range	Startup Time
120 to 277 Vac nominal	120 W	30 to 84 Vdc	1.05 to 3 A CC	up to 87% typical	90°C (measured at the hot spot)	< 20%	> 0.9	Forward-Phase, Reverse-Phase & 0 - 10V	1 - 100% (% of Iout)	400 ms

CC: Constant Current



**Metal Case**  
L 144 x W 70 x H 40 mm  
(L 5.67 x W 2.76 x H 1.57 in)

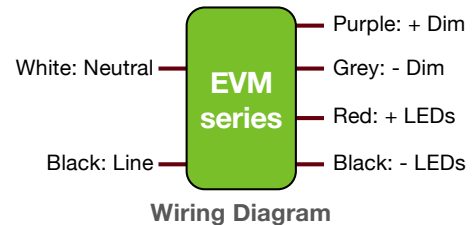
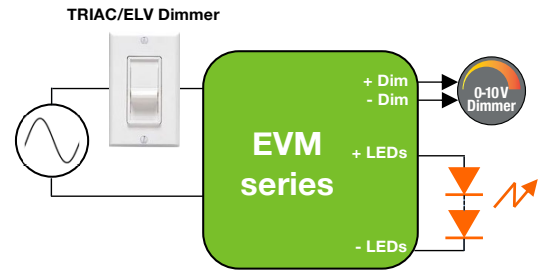

### FEATURES

- Compatible with TRIAC (forward-phase or leading-edge) / ELV (reverse-phase or trailing-edge) and 0-10 V dimmers
- TRIAC and ELV dimming only at 120 Vac
- Outdoor surge protection: 3 kV line to line/6 kV line to earth
- Linear 0-10V dimming transfer function: 10V=100%, 1V=10%, 0.1V=1%
- Optional non-linear 0-10V dimming profile with dim to off
- Lifetime: 50,000 hours @ Tc = 70° C
- 90°C maximum case hot spot temperature
- Class 2 power supply (only some models)
- IP20-rated Bottom Leads with Studs metal case with silicone-based potting. Optional IP64 metal case with side leads
- Protections: output open load, over-current and short-circuit (hiccup), and over-temperature with auto recovery
- Conducted and radiated EMI: Compliant with FCC CFR Title 47 Part 15 Class B (120 Vac) and Class A (277 Vac)
- Complies with ENERGY STAR® luminaire specification and DLC (Design Light Consortium®) technical requirements
- Worldwide safety approvals

### APPLICATIONS

- High Bay Lights
- Industrial LED Lighting
- Metal Halide replacement
- Tunnels and street lighting
- Outdoor LED Lighting
- Wide-area downlights
- Suitable for driving high current COB LEDs such as Cree's CXA3050/3070/3590, Bridgelux' Vero series and modules such as Cree's LMH2 6000/8000



## 60 to 120 W Constant Current LED Drivers with Tri-Mode Dimming™ (TRIAC, ELV & 0-10 V)

### 1 - ORDERING INFORMATION - MODEL DESCRIPTION

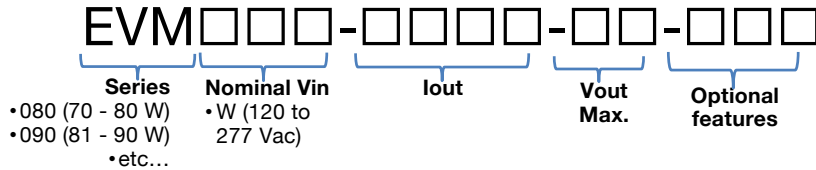

ERP Part Number	Nominal Input Voltage (Vac)	Iout (mA)	Max Output Power (W)	Vout Min (Vdc)	Vout Nom (Vdc)	Vout Max (Vdc)	No Load Voltage (Vdc)	Comments
<b>EVM060W: up to 60W</b>								
EVM060W-1400-42-Z1B	120 to 277	1400	58.8	30	37.8	42	50	Non-linear 0-10V dimming profile with dim-to-off 10V to 8.1V=100%, 1V to 0.8V=1%, <0.8V=dim-to-off
<b>EVM080W: 71-80W</b>								
EVM080W-1750-42-Z1B	120 to 277	1750	73.5	30	37.8	42	50	Non-linear 0-10V dimming profile with dim-to-off 10V to 8.1V=100%, 1V to 0.8V=1%, <0.8V=dim-to-off
EVM080W-1900-42	120 to 277	1900	79.8	30	37.8	42	50	
<b>EVM090W: 81-90W</b>								
EVM090W-1050-84 <sup>[1]</sup>	120 to 277	1050	88.2	70	75.6	84	100	
EVM090W-1700-48-N1B <sup>[2]</sup>	120 to 277	1700	81.6	37	43.2	48	60	Customized 0-10V dimming profile (10V=100%, 1V=1%) and dim-to-off
EVM090W-2000-42-S	120 to 277	2000	84.0	30	37.8	42	50	Side leads no studs case, IP64
EVM090W-2000-42-Z1	120 to 277	2000	84.0	30	37.8	42	50	Non-linear 0-10V dimming profile with dim-to-off 10V to 8.1V=100%, 1V to 0.8V=1%, <0.8V=dim-to-off
<b>EVM100W: 91-100W</b>								
EVM100W-2100-45	120 to 277	2100	94.5	32	40.5	45	58.5	
EVM100W-2350-42	120 to 277	2350	98.7	30	37.8	42	50	
<b>EVM120W: 111-120W</b>								
EVM120W-2700-42 <sup>[1]</sup>	120 to 277	2700	113.4	30	37.8	42	50	

**Notes:**

- (1) Not class 2.
- (2) The EVM090W-1700-48-N1B is specifically intended to drive the Cree LMH2 6000 module and exhibits a customized 0-10V dimming transfer function.
- For additional options of output current and output voltage, contact your sales representative or send an email to: [SaveEnergy@ERP-Power.com](mailto:SaveEnergy@ERP-Power.com)

## 60 to 120 W Constant Current LED Drivers with Tri-Mode Dimming™ (TRIAC, ELV & 0-10 V)

### 2 - INPUT SPECIFICATION (@25°C ambient temperature)

	Units	Minimum	Typical	Maximum	Notes
<b>AC Line Input Voltage Range (Vin)</b>	Vac	90	120, 230, 277	305	The rated output current for each model is achieved at Vin ≥ 108 Vac and at Vin ≥ 198 Vac, at nominal load.
<b>Input Frequency Range</b>	Hz	47	60 / 50	63	
<b>Input Current (Iin)</b>	A			1.5 A @ 120 VAC 0.8 A @ 230 VAC 0.7 A @ 277 VAC	
<b>Power Factor (PF)</b>		0.9	> 0.9		At nominal input voltage
<b>Inrush Current</b>	A	Meets NEMA-410 requirements			At any point on the sine wave and 25°C
<b>Leakage Current</b>	µA			250 µA @ 120 Vac 500 µA @ 230 Vac 600 µA @ 277 Vac	Measured per IEC60950-1
<b>Input Harmonics</b>	Complies with IEC61000-3-2 for Class C equipment				
<b>Total Harmonics Distortion (THD)</b>				20%	•At nominal input voltage and nominal LED load •Complies with DLC (DesignLight Consortium) technical requirements
<b>Efficiency</b>			87% 89%	-	•At 120 Vac •At 277 Vac
<b>Isolation</b>	The AC input to the main DC output is isolated and meets Class II reinforced/double insulation power supply <input type="checkbox"/>				

### 3 - OUTPUT SPECIFICATION (@25°C ambient temperature)

	Units	Minimum	Typical	Maximum	Notes
<b>Output Voltage (Vout)</b>	Vdc	30		84.0	See ordering information for details
<b>Output Current (Iout)</b>	A	1.05		3	• See ordering information for details • The rated output current for each model is achieved at Vin ≥ 108 Vac and at Vin ≥ 198 Vac, at nominal load.
<b>Output Current Regulation</b>	%	-5		+5	Includes AC line voltage, load, and current set point variations
<b>Output Current Overshoot</b>	%	-	-	10	The driver does not operate outside of the regulation requirements for more than 500 ms during power on with nominal LED load and without dimmer.
<b>Ripple Current</b>	< 25% peak-to-peak of rated output current				• Measured at nominal LED voltage and nominal input voltage without dimming. • Calculated in accordance with the IES Lighting Handbook, 9th edition.
<b>Dimming Range (% of Iout)</b>	%	1		100	• The dimming range is dependent on each specific dimmer. It may not be able to achieve 1% dimming with some dimmers. • Dimming performance is optimal when the driver is operated at its nominal output voltage matching the LED nominal Vf (forward voltage). Dimming performance may vary when the driver is operated near its minimum output voltage.
<b>Start-up Time</b>	ms			400	• Measured from application of AC line voltage to the time where light is visible (about 10% of rated output current)
				500	• Measured from application of AC line voltage to 100% light output • Complies with California Title 24 and ENERGY STAR® luminaire specification

## 60 to 120 W Constant Current LED Drivers with Tri-Mode Dimming™ (TRIAC, ELV & 0-10 V)

### 4 - 0-10 V DIMMING CONTROL (@25° C ambient temperature)

	Units	Minimum	Typical	Maximum	Notes
<b>+Dim Signal, -Dim Signal</b>	The EVM series operate only with 0-10V dimmers that sink current. The method to dim the output current of the driver is done via the +Dim/-Dim Signal pins. The +Dim/-Dim signal pins can be used to adjust the output setting via a standard commercial wall dimmer, an external control voltage source (0 to 10 Vdc), or a variable resistor when using the recommended number of LEDs. The dimming input permits 1% to 100% dimming.				
<b>Dimming Range (% of Iout)</b>	%	1		100	<ul style="list-style-type: none"> <li>The dimming range is dependent on each specific dimmer. It may not be able to achieve 1% dimming with some dimmers.</li> <li>Dimming performance is optimal when the driver is operated at its nominal output voltage matching the LED nominal Vf (forward voltage). Dimming performance may vary when the driver is operated near its minimum output voltage.</li> </ul>
<b>Current Supplied by the +Dim Signal Pin</b>	mA			1	
<b>Output Current Tolerance While Being Dimmed</b>	%			±8	The tolerance of the output current while being dimmed is ≤ +/-8% until down to 1V.
<b>Isolation</b>	The 0-10 V circuit is isolated from the AC input and meets Class II reinforced/double insulation power supply. 				

### 5 - ENVIRONMENTAL CONDITIONS

	Units	Minimum	Typical	Maximum	Notes
<b>Operating Case Temperature (Tc)</b>	°C	-30		70	Case temperature measured at the hot spot •tc (see label in page 11)
<b>Maximum Case Temperature (Tc)</b>					Case temperature measured at the hot spot •tc (see label in page 11)
<b>Storage Temperature</b>	°C			90	
<b>Humidity</b>	%	5	-	95	Non-condensing
<b>Cooling</b>	Convection cooled				
<b>Acoustic Noise</b>	dBA			22	Measured at a distance of 1 foot (30 cm) without and with approved dimmers
<b>Mechanical Shock Protection</b>	per EN60068-2-27				
<b>Vibration Protection</b>	per EN60068-2-6 & EN60068-2-64				
<b>MTBF</b>	> 300,000 hours when operated at nominal input and output conditions, and at Tc ≤ 70°C				
<b>Lifetime (see graphs "Lifetime vs. Case and Ambient Temperature" in section 8)</b>	50,000 hours at 70°C maximum case hot spot temperature (see hot spot •tc on label in page 11)				

## 60 to 120 W Constant Current LED Drivers with Tri-Mode Dimming™ (TRIAC, ELV & 0-10 V)

### 6 - EMC COMPLIANCE AND SAFETY APPROVALS

EMC Compliance			
<b>Conducted and Radiated EMI</b>		FCC CFR Title 47 Part 15 Class B at 120 Vac and Class A at 277 Vac	
<b>Harmonic Current Emissions</b>		IEC61000-3-2	For Class C equipment
<b>Voltage Fluctuations &amp; Flicker</b>		IEC61000-3-3	
<b>Immunity Compliance</b>	<b>ESD (Electrostatic Discharge)</b>	IEC61000-4-2	6 kV contact discharge, 8 kV air discharge, level 3
	<b>RF Electromagnetic Field Susceptibility</b>	IEC61000-4-3	3 V/m, 80 - 1000 MHz, 80% modulated at a distance of 3 meters
	<b>Electrical Fast Transient</b>	IEC61000-4-4	± 2 kV on AC power port for 1 minute, ±1 kV on signal/control lines
	<b>Surge</b>	IEC61000-4-5	± 3 kV line to line (differential mode) /± 6 kV line to common mode ground (tested to secondary ground) on on AC power port, ±0.5 kV for outdoor cables
		ANSI/IEEE c62.41.1-2002 & c62.41.2-2002 category A, 2.5 kV ring wave	
	<b>Conducted RF Disturbances</b>	IEC61000-4-6	3 V, 0.15-80 MHz, 80% modulated
<b>Voltage Dips</b>	IEC61000-4-11	>95% dip, 0.5 period; 30% dip, 25 periods; 95% reduction, 250 periods	

### Safety Agency Approvals

<b>UL</b>	UL8750 recognized
<b>cUL</b>	CAN/CSA C22.2 No. 250.13-14 LED equipment for lighting applications

### Safety

	Units	Minimum	Typical	Maximum	Notes
<b>Hi Pot (High Potential) or Dielectric Voltage-Withstand</b>	Vdc	4242			<ul style="list-style-type: none"> <li>Insulation between the input (AC line and Neutral) and the output</li> <li>Tested at the RMS voltage equivalent of 3000 Vac</li> </ul>

### 7 - PROTECTION FEATURES

#### Under-Voltage (Brownout)

The EVM series provides protection circuitry such that an application of an input voltage below the minimum stated in paragraph 1 (Input Specification) shall not cause damage to the driver.

#### Short Circuit

The EVM series is protected against short-circuit such that a short from any output to return shall not result in a fire hazard or shock hazard. The driver shall hiccup as a result of a short circuit or over current fault. Removal of the fault will return the driver to within normal operation. The driver shall recover, with no damage, from a short across the output for an indefinite period of time.

#### Internal Over temperature Protection

The EVM series incorporates circuitry that prevents internal damage due to an over temperature condition. An over temperature condition may be a result of an excessive ambient temperature or as a result of an internal failure. When the over temperature condition is removed, the driver shall automatically recover.

#### Output Open Load

When the LED load is removed, the output voltage of the EVM series is limited to 1.3 times the maximum output voltage of each model.

## 60 to 120 W Constant Current LED Drivers with Tri-Mode Dimming™ (TRIAC, ELV & 0-10 V)

### 8 - PREDICTED LIFETIME VERSUS CASE AND AMBIENT TEMPERATURE

Lifetime is defined by the measurement of the temperatures of all the electrolytic capacitors whose failure would affect light output under the nominal LED load and worst case AC line voltage. The graphs in figure 1 are determined by the electrolytic capacitor with the shortest lifetime, among all electrolytic capacitors. They represent a worst case scenario in which the LED driver is powered 24 hours/day, 7 days/week. The lifetime of an electrolytic capacitor is measured when any of the following changes in performance are observed:

- 1) Capacitance changes more than 20% of initial value
- 2) Dissipation Factor ( $\tan \delta$ ): 150% or IEVM of initial specified value
- 3) Equivalent Series Resistance (ESR): 150% or IEVM of initial specified value
- 4) Leakage current: IEVM of initial specified value

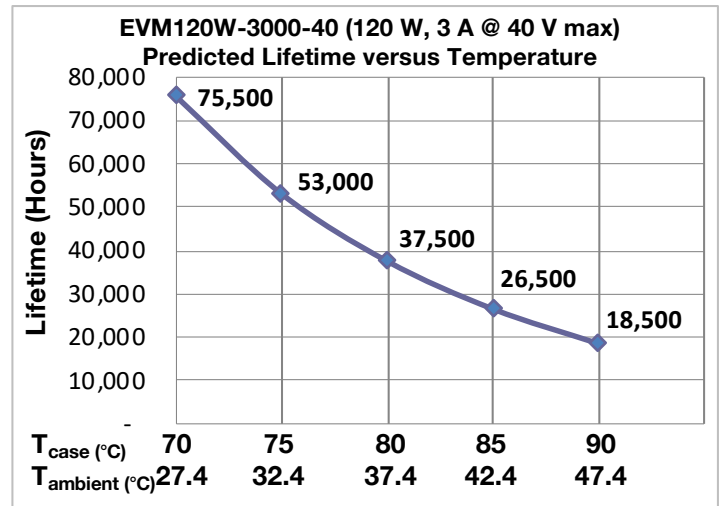
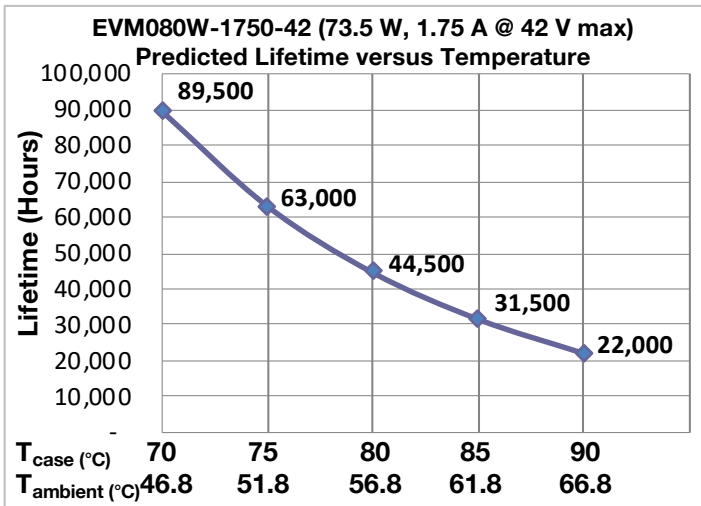
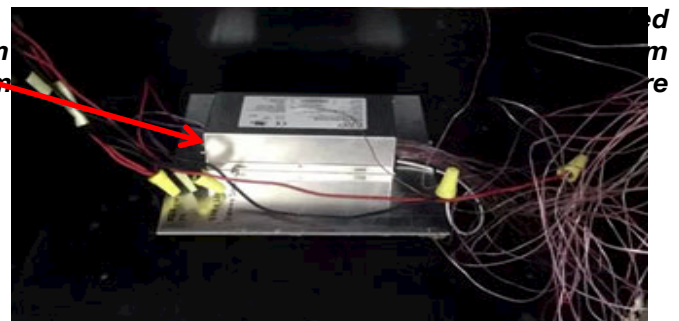

Figure 1

Notes:

- The ambient temperature  $T_{ambient}$  and the differential between  $T_{ambient}$  and  $T_{case}$  mentioned in the above graphs are relevant only as long as both the driver and the light fixture are exposed to the same ambient room temperature. If the LED driver is used in an enclosure or covered by insulation material, then the ambient room temperature is no longer valid. In this situation, please refer only to the case temperature  $T_{case}$ .
- It should be noted the graph "Lifetime vs. Ambient Temperature" may have an error induced in the final application if the mounting has restricted convection flow around the case. For applications where this is evident, the actual case temperature measured at the  $T_c$  point in the application should be used for reliability calculations.
- For EVM models  $\geq 90$  W, flush on a flat aluminum dimensions 210 mm x 200 mm, adequate thermal derating and life performance.



## 60 to 120 W Constant Current LED Drivers with Tri-Mode Dimming™ (TRIAC, ELV & 0-10 V)

### 9 - PHASE-CUT DIMMING

Dimming of the driver is possible with standard TRIAC-based incandescent dimmers that chop the AC voltage as shown in Figure 2, or with ELV dimmers. During the rapid rise time of the AC voltage when the dimmer turns on, the driver does not generate any voltage or current oscillations, and inrush current is controlled. During the on-time of the AC input, the driver regulates the output current based upon the conduction angle. The RMS value of the driver output current is proportional to the on-time of the AC input voltage. When operating with an incandescent dimmer, the RMS output current varies depending upon the conduction angle and RMS value of the applied AC input voltage. Figure 3 shows the typical output current versus conduction angle at nominal input voltage.

Forward-phase (TRIAC) and reverse-phase (ELV) dimming are only working at 120 Vac.

The EVM series offers tri-mode dimming compatibility with both phase-cut (reverse-phase and forward-phase) and 0-10V dimmers. Phase-cut dimming always has priority over 0-10 V dimming.

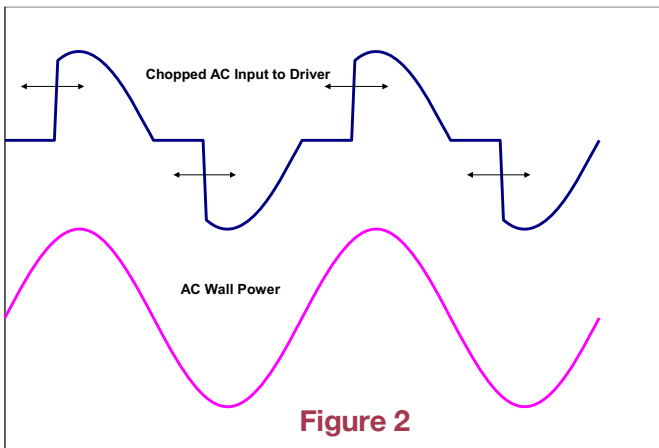

Figure 2

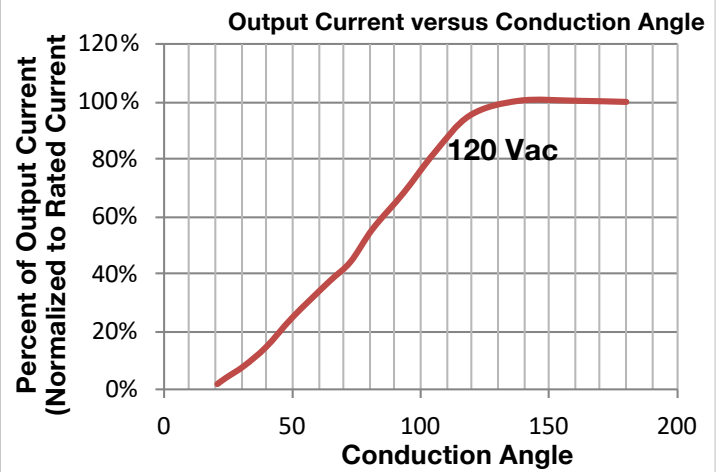

Figure 3

### 10 - COMPATIBLE PHASE-CUT DIMMERS & DIMMING RANGE

120Vac Dimmers					
Mfg.	Model	Mfg.	Model	Mfg.	Model
Lutron	S-603PG	Lutron	DVELV-303P	Lutron	CT-103P
Leviton	IPI06-1LZ	Lutron	SELV-300P	Cooper	SLC03P
Leviton	6631-2	Leviton	6683-IW	Leviton	IPE04
Lutron	DVCL-153P	Leviton	6161	Lutron	MAELV-600
Lutron	DV-600P	Leviton	6633-P	Lutron	FAELV-500
Lutron	TGCL-153P	Lutron	TG-600P	Lightolier	ZP260QEW
Lutron	S-600P	Cooper	DLC03P	Cooper	DAL06P
Leviton	VPE06	Lutron	LG-600P		

Dimming compatibility charts are available for each model in the EVM series. Please contact your sales representative or send an email to: [SaveEnergy@ERP-Power.com](mailto:SaveEnergy@ERP-Power.com).

## 60 to 120 W Constant Current LED Drivers with Tri-Mode Dimming™ (TRIAC, ELV & 0-10 V)

### 11 - 0-10 V DIMMING

The EVM drivers operate only with 0-10V dimmers that sink current. They are not designed to operate with 0-10V control systems that source current, as used in theatrical/entertainment systems. Developed in the 1980's, the 0-10V sinking current control method is adopted by the International Electrotechnical Commission (IEC) as part of their IEC Standard 60929 Annex E.

The method to dim the output current of the driver is done via the +Dim/-Dim Signal pins. The +Dim/-Dim Signal pins respond to a 0 to 10 V signal, delivering 1% to 100% of the output current based on rated current for each model. A pull-up resistor is included internal to the driver. When the +Dim wire (purple) is short circuited to the -Dim wire (grey) or to the -LED wire (black), a small amount of current may be present on the output and, in that condition, shimmering may be observed. If the +Dim input is  $\leq 1$  V and  $\geq 0.6$  V, the output current is still present, as shown in figure 4.

**Please note that short circuiting the +Dim wire (purple) to the -Dim wire (grey) does not guarantee that the output current is turned off. In some models, the current may turn off when short circuiting the +Dim wire to the -Dim wire. In other models, there may be a small amount of current still present.**

If the +Dim input is  $> 10$  V or open circuited, the output current is programmed to 100% of the rated current.

When not used, the -Dim wire (grey) and the +Dim wire (purple) can be individually capped or cut off. In this configuration, no dimming is possible and the driver delivers 100% of its rated output current.

The maximum source current (flowing from the driver to the 0-10V dimmer) supplied by the +Dim Signal pin is  $\leq 1$  mA. The tolerance of the output current while being dimmed shall be  $\pm 8\%$  typical until down to 1 V.

The linear 0-10V dimming profile is the default profile across most models of the EVM series. In the linear 0-10V dimming profile, shown in figure 4, 10 V = 100% of the output current and 1 V = 10 % of the output current.

Models with the "-Z1" suffix exhibit a non-linear 0-10 V dimming profile with dim-to-off, as shown in figure 5:

- Models with the "-Z1" suffix: 10V to 8.1V=100%, 1V to 0.8V=1%, Dim-to-off  $< 0.8$ V.

The non-linear curve is recommended when using standard in wall 0-10 V logarithmic dimmers to avoid having insufficient source current available to pull the dimmer up to 10V and to account for the inability of the dimmer to pull below approximately 0.9V. In these type of installations, the modified transfer function will ensure 100% light output and dimming to 1%, regardless of the number of drivers on the 0-10V dimming line. Please contact your sales representative or send an email to: [SaveEnergy@erp-power.com](mailto:SaveEnergy@erp-power.com) for additional information.

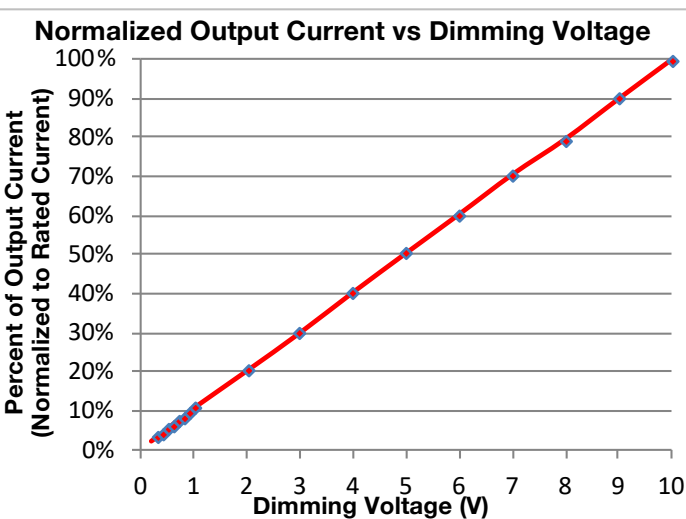

Figure 4

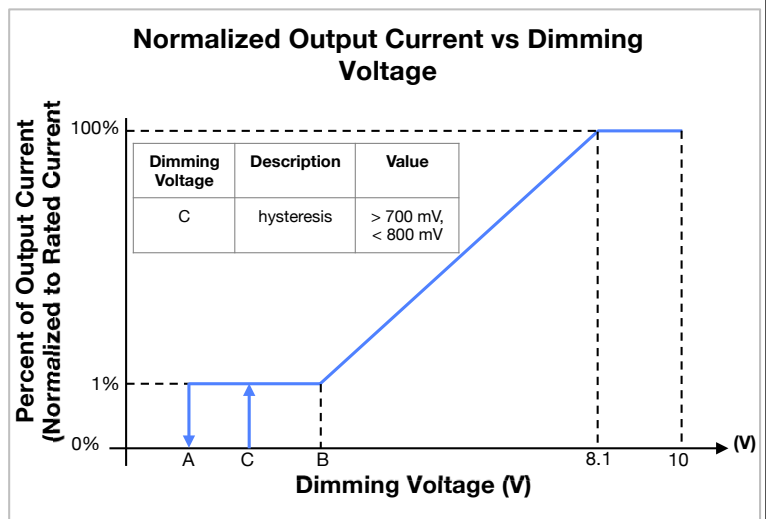

Figure 5



## 60 to 120 W Constant Current LED Drivers with Tri-Mode Dimming™ (TRIAC, ELV & 0-10 V)

### 11 - 0-10 V DIMMING (CONTINUED)

A fixed or variable resistor can be also used from the +Dim signal pin to the -Dim pin to adjust the output current. Figure 6 show the relationship of the output current to a resistor connected across the 0-10V dimming input. This is a typical graph for the entire EVM series but is not specific to a particular model. This graph may vary from one model to the next.

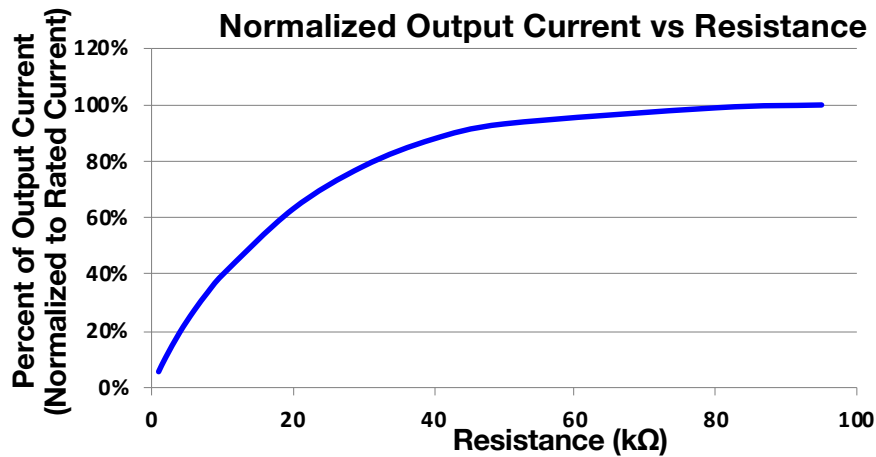

Figure 6

### 12 - COMPATIBLE 0-10 V DIMMERS

- Lutron, Nova series (part number NFTV)
- Lutron, Diva series (part number DVTV)
- Leviton, IllumaTech series (part number IP710-DL)

## 60 to 120 W Constant Current LED Drivers with Tri-Mode Dimming™ (TRIAC, ELV & 0-10 V)

### 13 - MECHANICAL DETAILS

**Packaging Options:** Metal case

**I/O Connections:** Flying leads, 18 AWG on power leads, 22 AWG on 0-10V dimming wires, 203 mm (8") long, 105°C rated, double insulated stranded, stripped by approximately 9.5mm and tinned. All the wires, on both input and output, have a 300 V insulation rating. Input wires have double insulation.

**Ingress Protection:** IP20 rated (IP64 for optional metal case with side leads)

**Mounting Instructions:** For EVM models  $\geq 90$  W, the driver must be mounted flush on a flat aluminum heatsink plate (minimum dimensions 210 mm x 200 mm x 2 mm) to ensure adequate thermal derating and life performance.

### 14 - OUTLINE DRAWINGS

**Dimensions:** L 144 x W 70 x H 40 mm (L 5.66 x W 2.76 x H 1.57 in)

**Volume:** 403.2 cm<sup>3</sup> (24.6 in<sup>3</sup>)

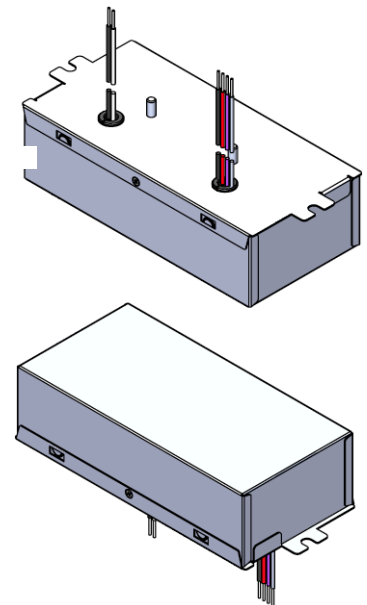
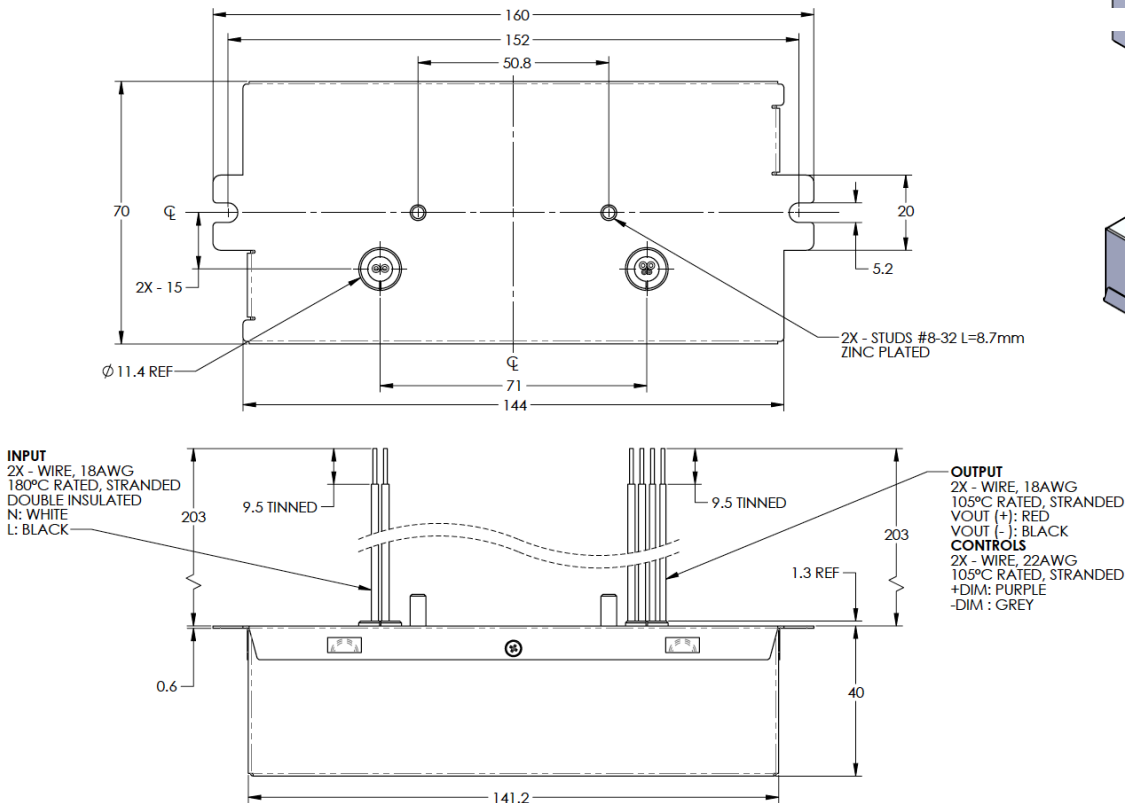

**Figure 7**

All dimensions are in mm

## 60 to 120 W Constant Current LED Drivers with Tri-Mode Dimming™ (TRIAC, ELV & 0-10 V)

### 15 – LABELING AND T<sub>c</sub> POINT LOCATION

The EVM090W-1700-48 is used in figures 8 & 9 as an example to illustrate a typical label.

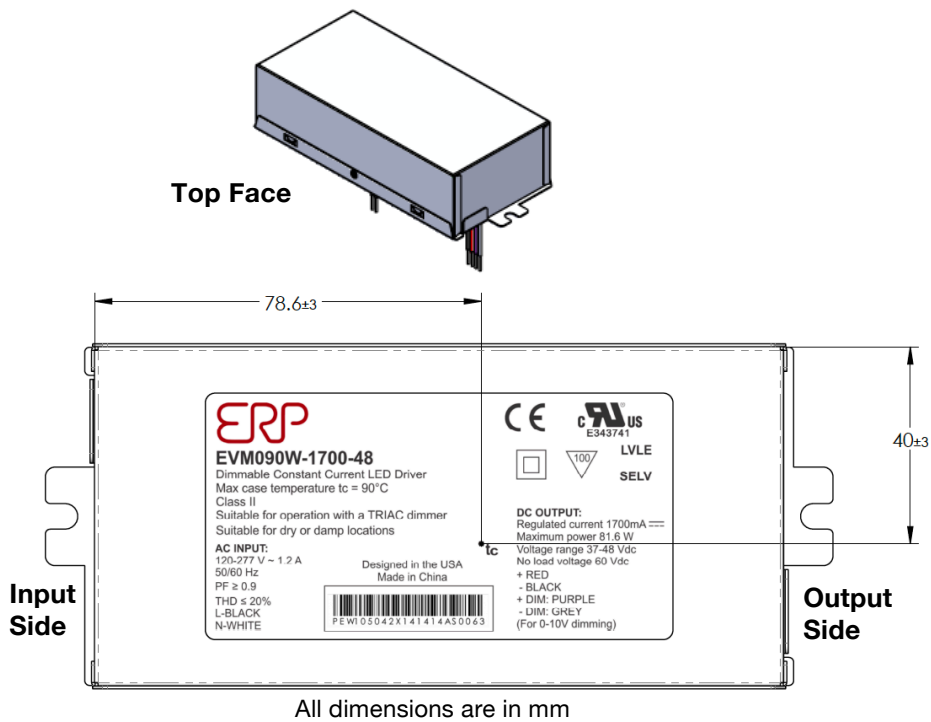

**Figure 8**

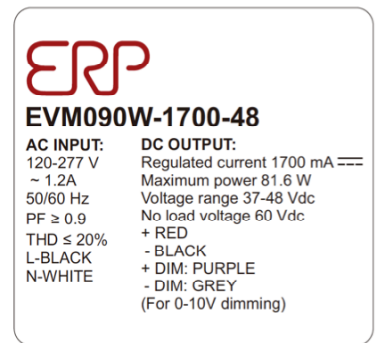
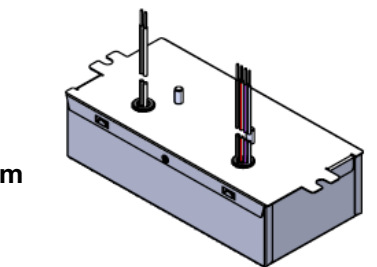

**Figure 9**

**USA Headquarters**  
 Tel: +1-805-517-1300  
 Fax: +1-805-517-1411  
 893 Patriot Drive, Suite E,  
 Moorpark, CA 93021, USA

**CHINA Operations**  
 Tel: +86-756-6266298  
 Fax: +86-756-6266299  
 No. 8 Pingdong Road 2  
 Zhuhai, Guangdong, China 519060

ERP Power, LLC (ERP) reserves the right to make changes without further notice to any products herein. ERP makes no warranty, representation or guarantee regarding the suitability of its products for any particular purpose, nor does ERP assume any liability arising out of the application or use of any product or circuit, and specifically disclaims any and all liability, including without limitation special, consequential or incidental damages. "Typical" parameters which may be provided in ERP data sheets and/or specifications can and do vary in different applications and actual performance may vary over time. All operating parameters, including "Typicals" must be validated for each customer application by customer's technical experts. ERP does not convey any license under its patent rights nor the rights of others. ERP products are not designed, intended, or authorized for use as components in systems intended for surgical implant into the body, or other applications intended to support or sustain life, or for any other application in which the failure of the ERP product could create a situation where personal injury or death may occur. Should Buyer purchase or use ERP products for any such unintended or unauthorized application, Buyer shall indemnify and hold ERP and its officers, employees, subsidiaries, affiliates, and distributors harmless against all claims, costs, damages, and expenses, and reasonable attorney fees arising out of, directly or indirectly, any claim of personal injury or death associated with such unintended or unauthorized use, even if such claim alleges that ERP was negligent regarding the design or manufacture of the part. ERP is an Equal Opportunity/Affirmative Action Employer. This literature is subject to all applicable copyright laws and is not for resale in any manner.