

## ELECTRONIC - CONSTANT VOLTAGE TRIAC (PHASE-CUT) DIMMABLE DRIVER

LR36160

LED/EDRV/300W/24V/UNV/D/JB



300W DRIVER

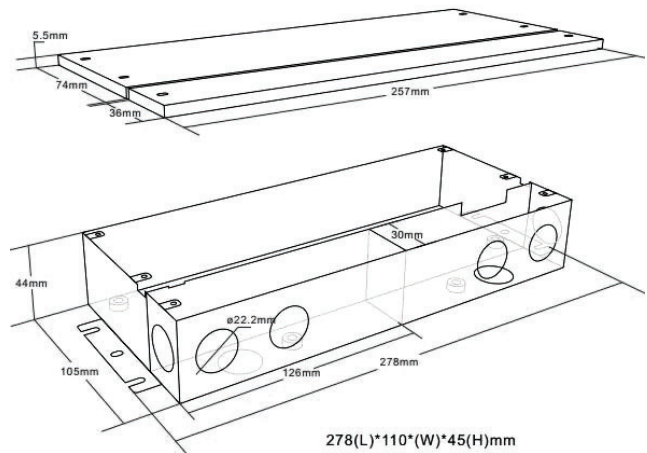

OUTPUT	RATED POWER	300W
	DC VOLTAGE	24V
	RATED CURRENT	12.5A
	VOLTAGE TOLERANCE	±0.5V
	VOLTAGE REGULATION	±0.5%
	LOAD REGULATION	±1%
INPUT	VOLTAGE RANGE	110-277VAC
	FREQUENCY RANGE	47-63Hz
	POWER FACTOR (TYP.) @ FULL LOAD	0.99 @ 120VAC - 0.97 @ 277VAC
	THD (TYP.) @ FULL LOAD	<20%
	EFFICIENCY (TYP.) @ FULL LOAD	86%
	AC CURRENT (MAX)	3.4A @ 110VAC
	INRUSH CURRENT (TYP.)	20A, 50%, 1.9ms
	LEAKAGE CURRENT	<0.50mA
PROTECTION	SHORT CIRCUIT	Shut down o/p voltage, re-power on to recover after fault condition removed
	OVER LOADING	≤120% Hiccup mode, recovers automatically after fault condition is removed
	OVER TEMPERATURE	212° F (100°C) ±50°F (10°C) shut down o/p voltage, automatically recover after cooling
ENVIRONMENT	WORKING TEMP	-40~+140°F (-40~60°C)
	WORKING HUMIDITY	20~90%RH, non-condensing
	STORAGE TEMP. HUMIDITY	-40~+176°F (-40~80°C), 10~95%RH
	TEMP. COEFFICIENT	±0.03% /°C (0~50°C)
	VIBRATION	10~500Hz, 5G 10 min/1 cycle, period for 60 min each along X,Y,Z axes
SAFETY & EMC	SAFETY STANDARDS	UL8750
	WITHSTAND VOLTAGE	I/P - O/P: 1.88KVAC
	ISOLATION RESISTANCE	I/P - O/P: 100M <sup>Ω</sup> /500VDC/25°C/70%RH
	EMC EMISSION	FCC Part 15B
CASE	NET WEIGHT	4.18lb (1.9 KG)
	SIZE	10.94" X 4.33" X 1.77" (L*W*H)
	CARTON SIZE	10 PCS/CTN