

CCT TUNABLE TAPE LIGHT CONTROLLER LR36176

CCT TUNABLE TAPE LIGHT CONTROLLER

- 4096 levels 0-100% dimming smoothly without any flash.
- Match with RF 2.4G single zone or multiple zone dual color or single color remote control.
- One RF controller accept up to 10 remote control.
- Auto-transmitting function: Controller automatically transmit signal to another controller with 30m control distance.
- Synchronize on multiple number of controllers.
- Fade in and out effect selectable.
- Can be set 3 levels color temperature (WW, NW and CW) selectable by continuous power off and on operation.

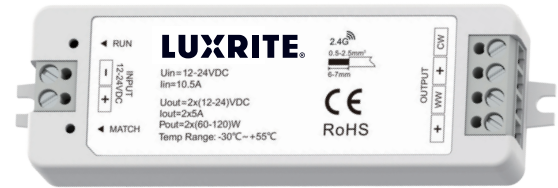

CE RoHS emc RED

2 Channel / Step-less dimming / Wireless remote control / Auto-transmitting / Synchronize

PARAMETERS

INPUT AND OUTPUT		DIMMING DATA		SAFETY AND EMC	
Input voltage	12-24VDC	Input signal	RF 2.4GHz	EMC standard (EMC)	ETSI EN 301 489-1 V2.2.3 ETSI EN 301 489-17 V3.2.4
Input current	10.5A	Control distance	30m(Barrier-free space)	Safety standard	EN 61348-1:2015+A1:2021 EN 61348-2-13:2014+A1:2017
Output voltage	2 x (12-24)VDC	Dimming gray scale	4096 (2 ¹²) levels	Radio Equipment (RED)	ETSI EN 300 328 V2.2.2
Output current	2CH,5A/CH	Dimming range	0 -100%	Certification	CE, EMC, RED
Output power	2x(60-120W)	Dimming curve	Linear		
Output type	Constant voltage	PWM frequency	2KHz (default)		

WARRANTY AND PROTECTION		ENVIRONMENT		PACKAGE	
Warranty	5 years	Operation temperature	Ta: -22°F ~ +131°F	Size	L4.48" x W1.49" x H1.02"
Protection	Reverse polarity Short circuit	Case temperature (Max.)	Tc: +185°F	Gross weight	1.08lb (0.049kg)
		IP rating	IP20		

MECHANICAL STRUCTURES AND INSTALLATIONS

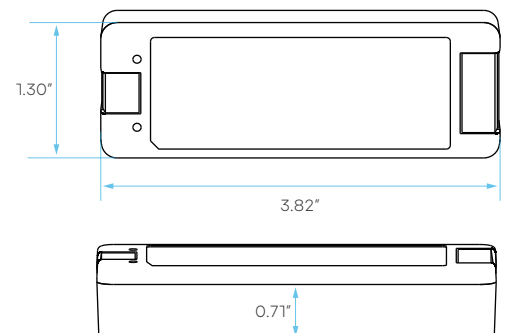
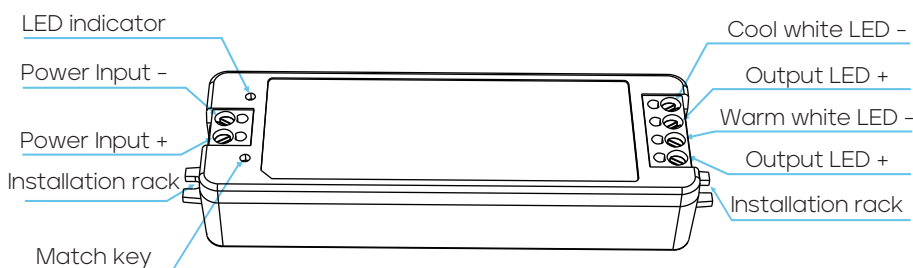

MATCH REMOTE CONTROL (TWO MATCH WAYS)

End user can choose the suitable match/delete ways. Two options are offered for selection:

Use the controller's Match key

Match:

Short press match key, immediately press on/off key (single zone remote) or zone key (multiple zone remote) of the remote.

The LED indicator fast flash a few times means match is successful.

Delete:

Press and hold match key for 5s to delete all match,

The LED indicator fast flash a few times means all matched remotes were deleted.

Use Power Restart

Match:

Switch off the power, then switch on power, repeat again. Immediately short press on/off key (single zone remote) or zone key (multiple zone remote) 3 times on the remote. The light blinks 3 times means match is successful.

Delete:

Switch off the power, then switch on power, repeat again.

Immediately short press on/off key (single zone remote) or zone key (multiple zone remote) 5 times on the remote. The light blinks 5 times means all matched remotes were deleted.

WIRING DIAGRAM

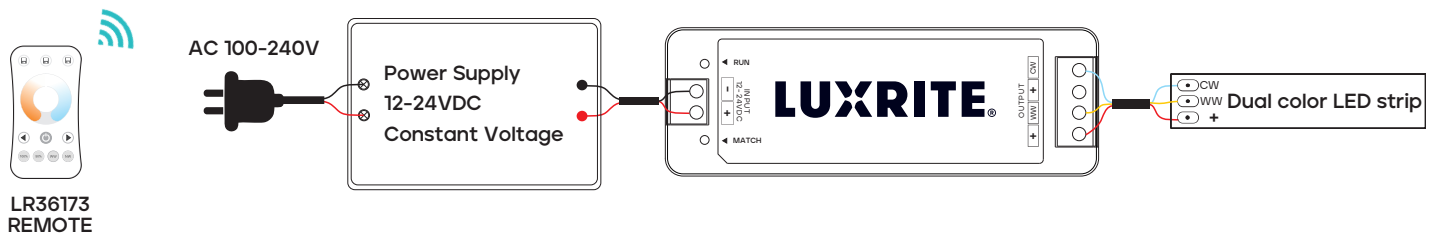

Note:

- Long press the match key for 15s to enable the continuous switch off-on two times rapidly to switch 3 levels color temperature function (This feature is disabled by factory default).
Long press the match key for 10s to restore the factory setting.
- Power failure memory: after setting the light state for 5s, the current light state will be saved automatically, the light state will not be changed when re-powering.

Wire Preparation:

1. The wiring can be solid or stranded with a cross-sectional area of 0.5 to 2.5 mm².
Conventional 1mm² can withstand 10A output current.
2. When wiring is installed, the terminals must be tightened.
If they are not tightened, the contact point resistance will be too high and the terminals will easily burn due to heat when used at full load for a long time.
3. The output power of a constant voltage power supply should be at least 1.2 times that of the output load (light strip), otherwise the full power output of the load can easily cause automatic flickering or shaking of the light.

0.02"-0.10"
0.24"-0.28"



LIGHT ON/OFF FADE TIME

Long press match key 5s, then short press match key 3 times, the lighting effect will be set to the fade in and fade out in 3s, the indicator light of LED controller blinks 3 times.

Long press match key 10s, restore factory default parameter, the light on/off time restores to 0.5s.

DUAL COLOR CONTROL

WW=Warm white LED CW=Cool white LED Each channel can supply up to 120W(@24V) and white balance can be controlled as such:

COLOR TEMPERATURE	COOL WHITE	NEUTRAL WHITE	WARM WHITE
Power distribution	WW=0W,CW=120W	WW=60W,CW=60W	WW=120W,CW=0W

Linear dual color tuning

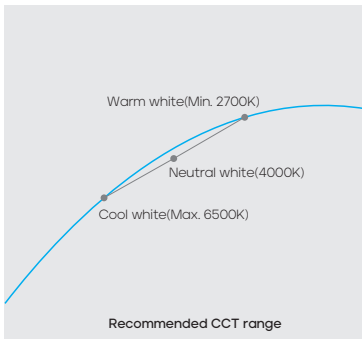

Dimming curve

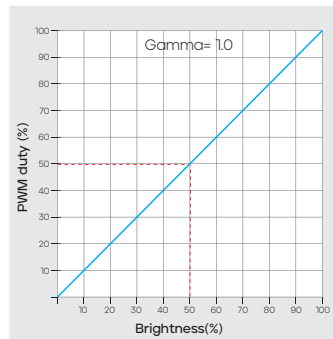

MALFUNCTIONS ANALYSIS & TROUBLESHOOTING

MALFUNCTIONS	CAUSES	TROUBLESHOOTING
No light	<ol style="list-style-type: none"> 1. No power. 2. Wrong connection or insecure. 	<ol style="list-style-type: none"> 1. Check the power. 2. Check the connection.
Uneven intensity between front and rear, with voltage drop	<ol style="list-style-type: none"> 1. Output cable is too long. 2. Wire diameter is too small. 3. Overload beyond power supply capability. 4. Overload beyond controller capability. 	<ol style="list-style-type: none"> 1. Reduce cable or loop supply. 2. Change wider wire. 3. Replace higher power supply. 4. Add power repeater.
No response from the remote	<ol style="list-style-type: none"> 1. The battery has no power. 2. Beyond controllable distance. 3. The controller did not match the remote. 	<ol style="list-style-type: none"> 1. Replace battery. 2. Reduce remote distance. 3. Re-match the remote.

INSTALLATION PRECAUTIONS

1. The products shall not be stacked, the distance should be $\geq 20\text{cm}$, so as not to affect lifespan of the products due to poor heat dissipation.
2. The product shall not be installed close to the switching power supply with an interval of $\geq 20\text{cm}$ to avoid radiation interference of the switching power supply.
3. The installation height shall be $\geq 1\text{m}$ from the floor to avoid shortening the remote control distance due to too weak reception signal.
4. The products are not allowed to be close to or covered by metal objects, with an interval of $\geq 20\text{cm}$ to avoid signal attenuation and shorten the remote distance.
5. Avoid installation at the corner of the wall or the corner of the beam, with an interval of $\geq 20\text{cm}$ to avoid signal interference.