

KT-WDLEDXXPS-XA-9CSF-VDIM

CIRCULAR LED SLIM WAFER DOWNLIGHT

INSTALLATION INSTRUCTIONS

PLEASE FIND A QUALIFIED ELECTRICIAN FOR INSTALLATION. Please read the instructions before installation and use.

- WARNING**
- Before installing, servicing, or performing routine maintenance upon this equipment, follow these general precautions.
 - Risk of fire or electric shock. LED retrofit kit installation requires knowledge of luminaire electrical systems.
 - If not qualified, do not attempt installation; contact a qualified electrician.
 - Risk of fire or electric shock. Install this kit only in luminaires that have the construction features and dimensions shown in the photographs and/or drawings and where the input rating of the retrofit kit does not exceed the input rating of the luminaire.
 - To reduce the risk of death, personal injury or property damage from fire, electric shock, failing parts, cuts/abrasions, and other hazards, read all warnings and instructions with and on the fixture box and all fixture labels.
 - Installers should not disconnect existing wires from lampholder terminals to make new connections at lampholder terminals. Instead, installers should cut existing lampholder leads away from the lampholder and make new electrical connections to lampholder lead wires by employing applicable connectors.
 - This retrofit kit is accepted as a component of a luminaire where the suitability of the combination shall be determined by authorities having jurisdiction.
 - To prevent wiring damage or abrasion, do not expose wiring to edges of sheet metal or other sharp objects.
 - Do not make or alter any open holes in an enclosure of wiring or electrical components during kit installation.

- WARNING**
- Turn off electrical power at fuse or circuit breaker box before wiring fixture to the power supply.
 - Turn off the power when you perform any maintenance.
 - Verify that supply voltage is correct by comparing it with the luminaire label information.
 - This device is not intended for use with emergency exits.

- CAUTION**
- Avoid direct eye exposure to the light source while it is on.
 - Account for small parts and destroy packing material, as these may be hazardous to children.
 - Risk of burn. Disconnect power and allow fixture to cool before changing bulb or handling fixture.

- NOTES**
- Specifications and dimensions subject to change without notice.
 - Suitable for wet locations.

NOTE
This equipment has been tested and found to comply with the limits for a Class A digital device, pursuant to Part 15 of the FCC Rules. These limits are designed to provide reasonable protection against harmful interference in a commercial installation. This equipment generates, uses and can radiate radio interference energy and, if not installed and used in accordance with the instructions, may cause harmful interference to radio communications. However, there is no guarantee that interference will not occur in a particular installation. If this equipment does cause harmful interference to radio or television reception, which can be determined by turning the equipment off and on, the user is encouraged to try to correct the interference by one or more of the following measures:

- Reorient or relocate the receiving antenna.
- Increase the separation between the equipment and receiver.
- Connect the equipment into an outlet on a circuit different from that to which the receiver is connected.
- Consult the dealer or an experienced radio/TV technician for help.

Caution: Before installing, make certain that AC power to the fixture is off.

COMPONENTS INCLUDED IN KIT

Part	Quantity
LED Wafer Downlight Fixture	1
Driver/Junction Box	1
Installation Hole Template	1

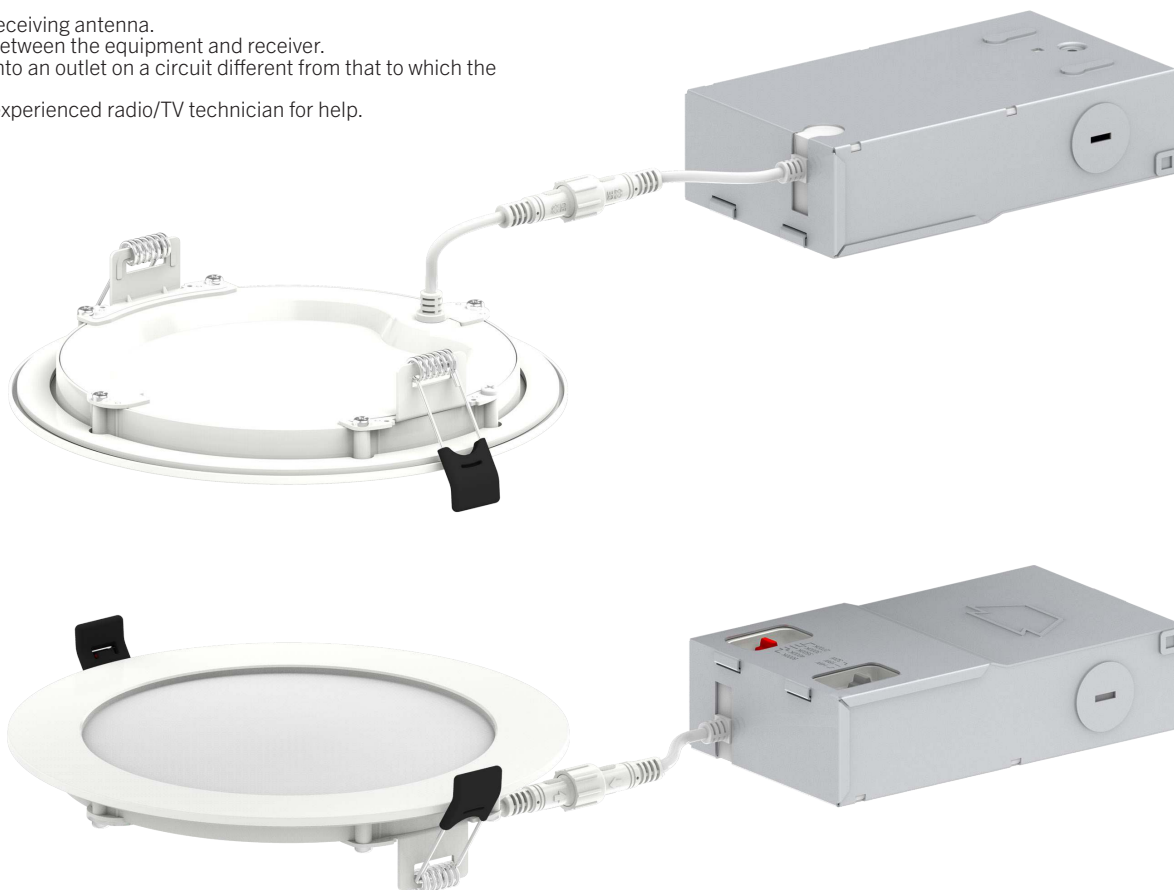

DIMENSIONS

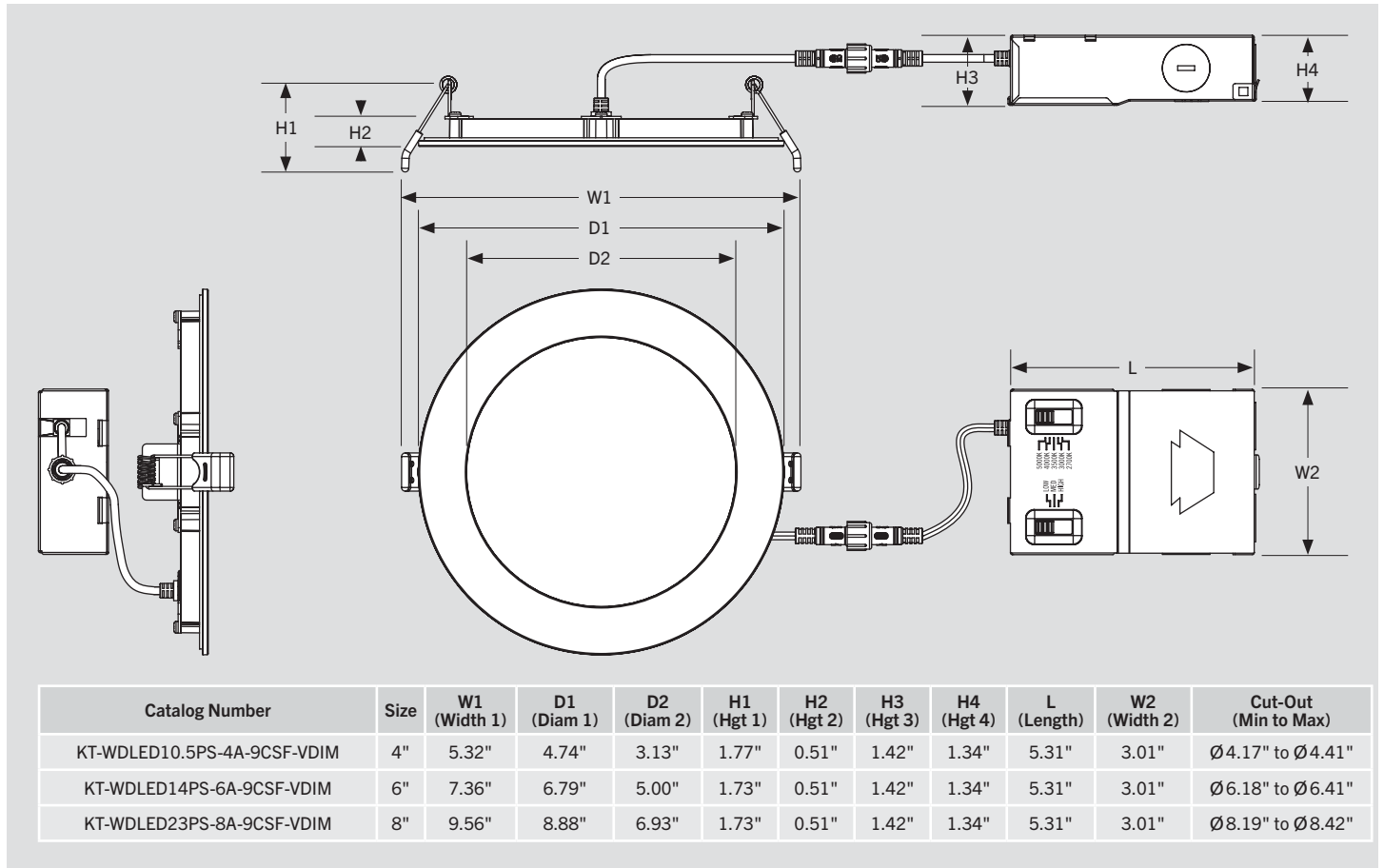

POWER SELECT (WATTAGE) AND COLOR SELECT (CCT) ADJUSTMENT

This fixture is equipped with field-adjustable Keystone Power Select and Color Select technology.

1. Ensure power is off to the fixture.
2. Adjust dip switches to desired settings.

KT-WDLED10.5PS-4A-9CSF-VDIM

Wattage	CCT
10.5W 9.5W 8.5W	2700K
	3000K
	3500K
	4000K
	5000K

KT-WDLED14PS-6A-9CSF-VDIM

Wattage	CCT
14W 12W 10W	2700K
	3000K
	3500K
	4000K
	5000K

KT-WDLED23PS-8A-9CSF-VDIM

Wattage	CCT
23W 18W 14W	2700K
	3000K
	3500K
	4000K
	5000K

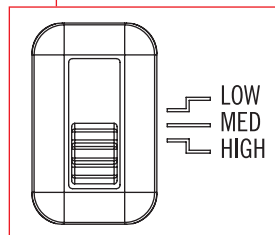
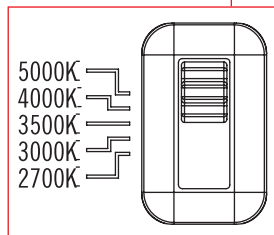
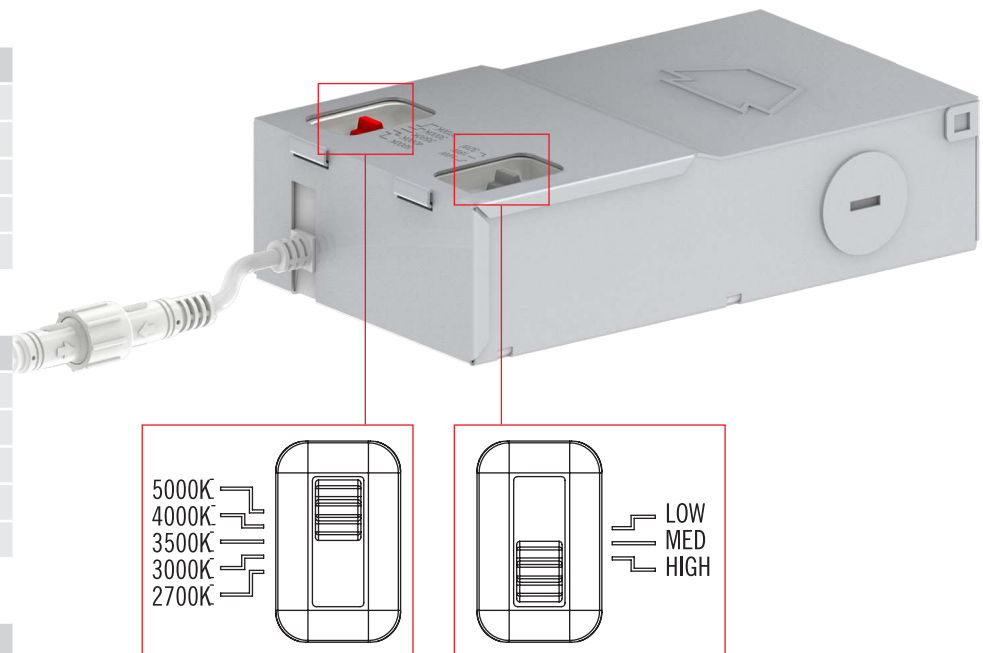

COLOR SELECT ADJUSTMENT SWITCH
Set dip switch to adjust CCT between five available CCTs. Fixture comes preset at highest CCT.



POWER SELECT ADJUSTMENT SWITCH
Set dip switch to adjust wattage between three available wattages. Fixture comes preset at highest wattage.

INSTALLATION INSTRUCTIONS

WIRING DIAGRAM

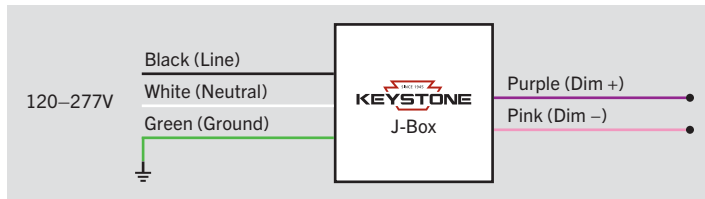

*In accordance with NEC-20 410.69 2022, all 0-10V negative wires have been updated from gray to pink. Please contact Keystone for details.

RETROFIT INSTALLATION

1. Shut off power at the source of the fixture housing into which you are installing fixture.

Remove existing trim, CFL or incandescent bulb.

Note: Follow all federal and local regulations when disposing of lamps and removed components.

2. Measure ceiling opening to ensure that the edge of the luminaire will cover the entire opening and still sit firmly in the ceiling (see Dimensions on page 2).

3. Select desired Wattage and CCT using adjustment switches on fixture (see Power Select (Wattage) and Color Select (CCT) Adjustment on page 2).

4. Open the driver box and remove the knockout(s) (KO).

5. Insert the electrical supply cable through the KO; use appropriate bushing to prevent wire abrasion. Wire driver box (see Wiring Diagram above and illustration below).*

6. Place all wiring and connections back into the box and close the cover.

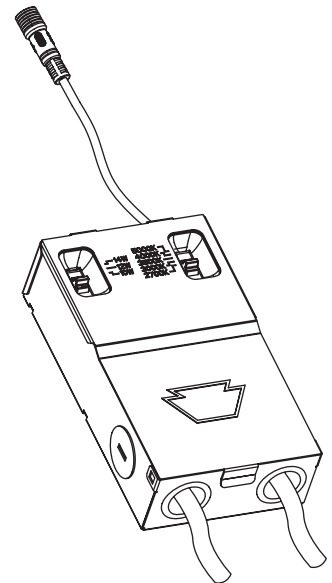
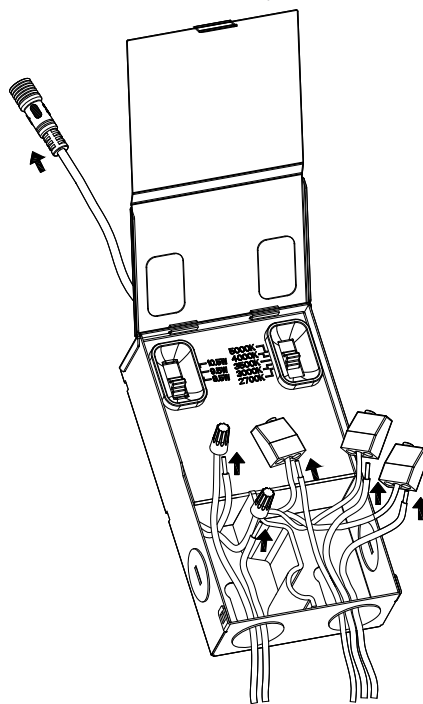
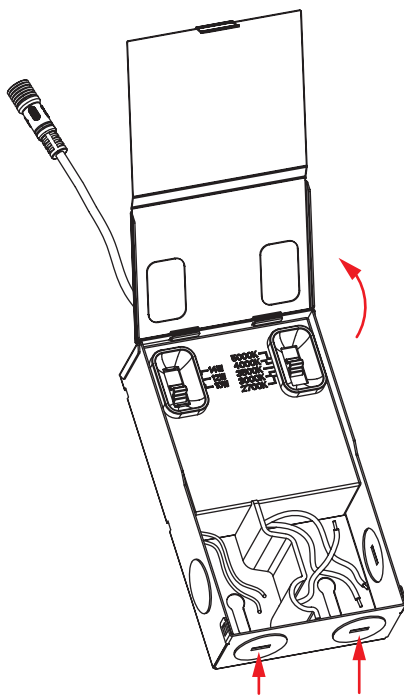

7. Insert driver box into ceiling in accordance with local/national codes and connect the male and female connectors. Screw threaded nut over connectors to secure.

8. Lifting both retention tabs upward, push the fixture into the hole until trim sits flush with ceiling.

9. Restore power when ready.

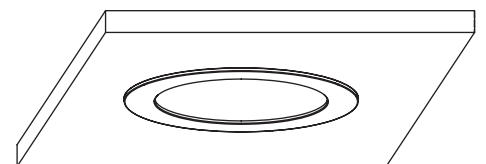
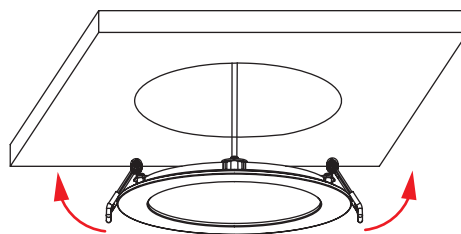
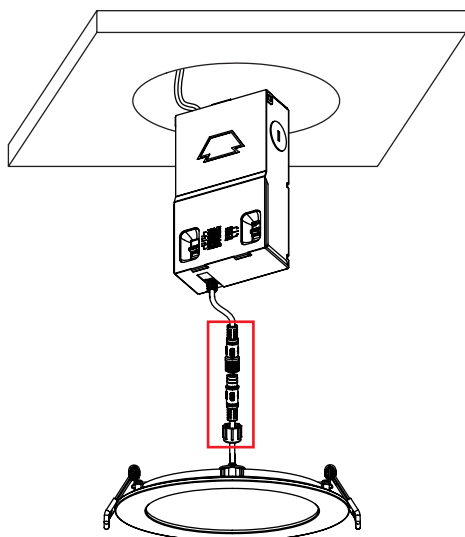

* Keystone offers an optional cable accessory to assist with wiring to existing fixture J-box. See KT-MC-NP-1-18/3, *Optional Accessories (sold separately)* on page 9.

Installation Instructions continued on next page

INSTALLATION INSTRUCTIONS *(continued)*

NEW-CONSTRUCTION INSTALLATION

1. Shut off power at the source of the fixture housing into which you are installing fixture.

2. Using installation hole template, create ceiling opening to ensure that the edge of the luminaire will cover the entire opening and still sit firmly in the ceiling (see *Dimensions* on page 2).

3. Select desired Wattage and CCT using adjustment switches on fixture (see *Power Select (Wattage) and Color Select (CCT) Adjustment* on page 2).

4. Open the driver box and remove the knockout(s) (KO).

5. Insert the electrical supply cable through the KO; use appropriate bushing to prevent wire abrasion. Wire driver box (see *Wiring Diagram* above and illustration below).*

6. Place all wiring and connections back into the box and close the cover.

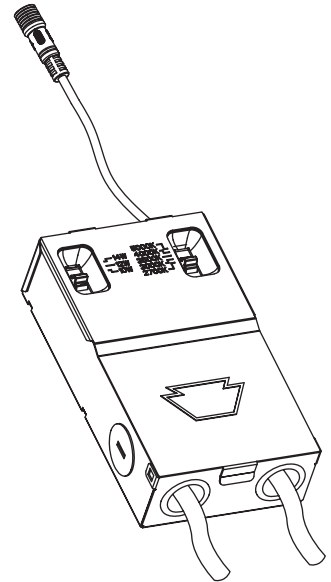
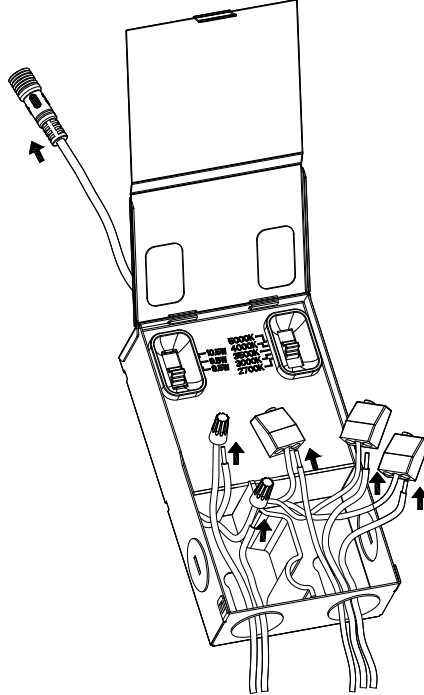
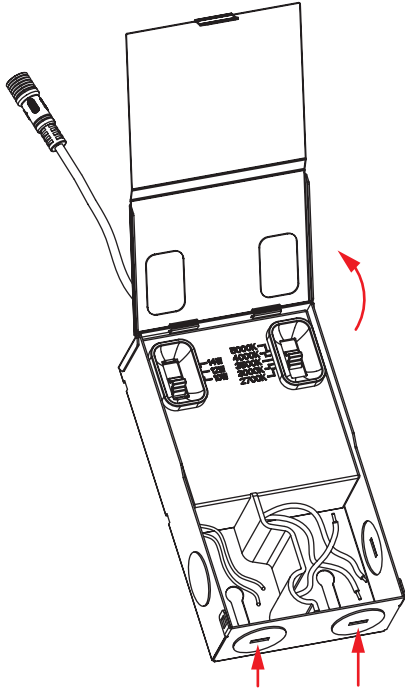

7. Insert driver box into ceiling in accordance with local/national codes and connect the male and female connectors. Screw threaded nut over connectors to secure.

8. Lifting both retention tabs upward, push the fixture into the hole until trim sits flush with ceiling.

9. Restore power when ready.

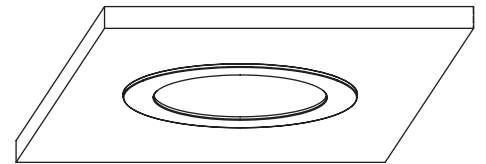
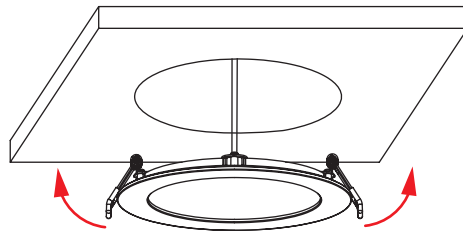
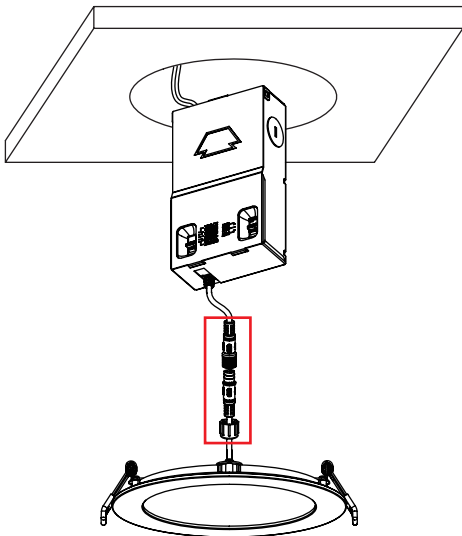

OPTIONAL ACCESSORIES (sold separately)

INTERCHANGEABLE TRIM RINGS FOR LED SLIM WAFER DOWNLIGHTS

Dimensions

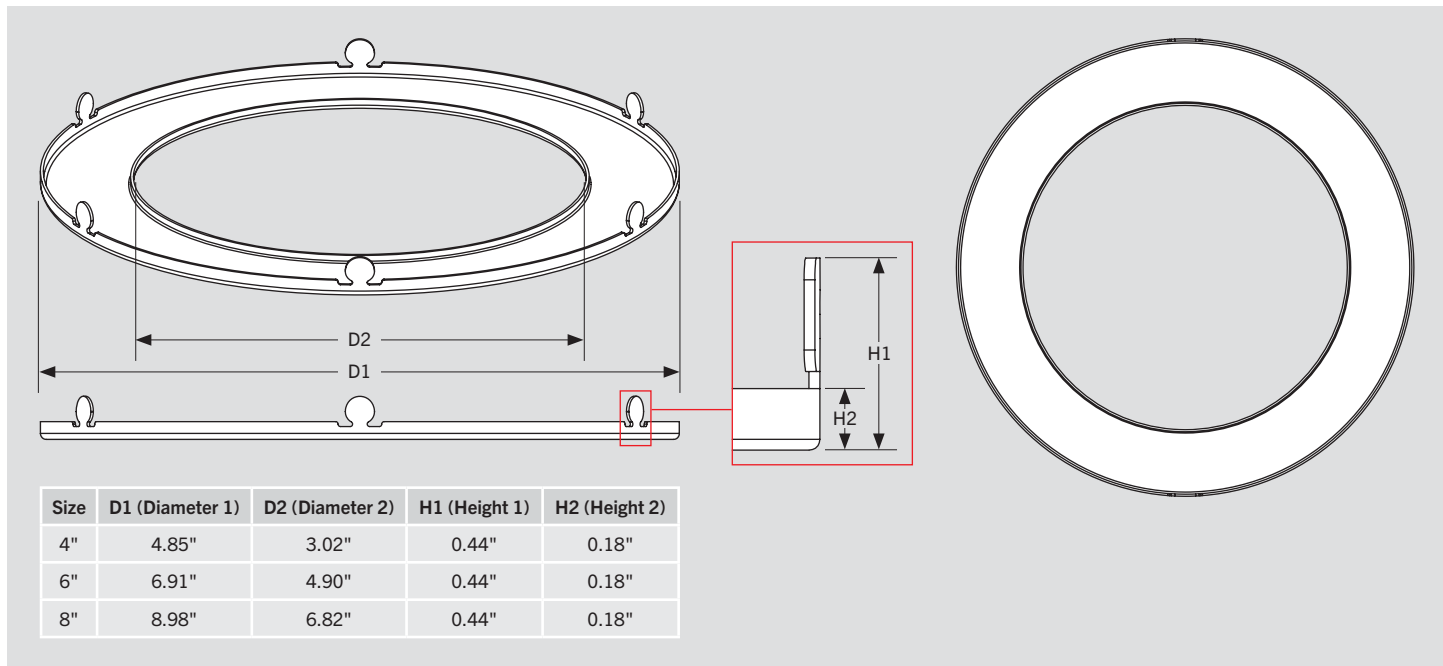

Installation

1. Clamp trim ring over fixture trim.
2. Secure trim ring to lighting fixture by bending tabs until trim ring is flush with trim.

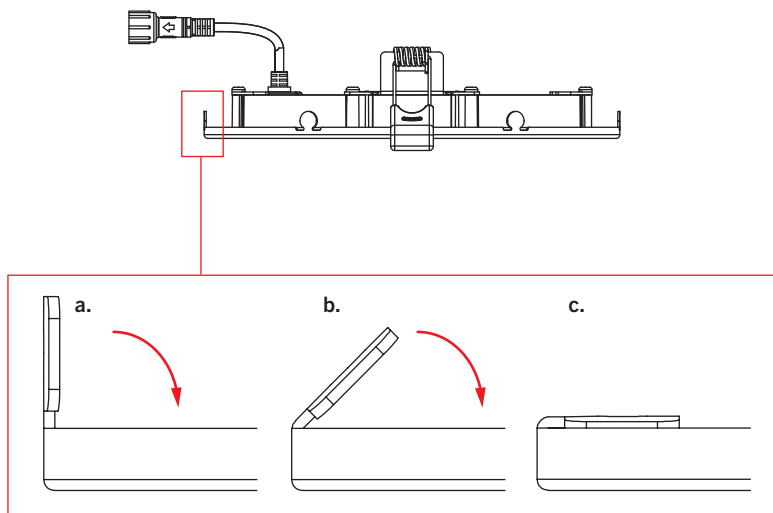
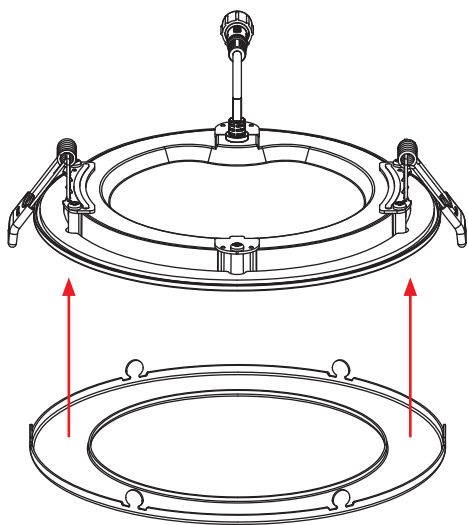

Ordering Information

Catalog Number	Description	UPC	Easy Code
KT-WDLED-4A-MB-TRIM	4" Interchangeable Trim for 4A Slim Wafer Downlights; Matte black	843654139319	ULJ-16
KT-WDLED-4A-BN-TRIM	4" Interchangeable Trim for 4A Slim Wafer Downlights; Brushed nickel	843654139340	IEJ-60
KT-WDLED-4A-BR-TRIM	4" Interchangeable Trim for 4A Slim Wafer Downlights; Bronze	843654139371	NTI-74
KT-WDLED-6A-MB-TRIM	6" Interchangeable Trim for 6A Slim Wafer Downlights; Matte black	843654139326	IFV-73
KT-WDLED-6A-BN-TRIM	6" Interchangeable Trim for 6A Slim Wafer Downlights; Brushed nickel	843654139357	PJM-11
KT-WDLED-6A-BR-TRIM	6" Interchangeable Trim for 6A Slim Wafer Downlights; Bronze	843654139388	RXK-07
KT-WDLED-8A-MB-TRIM	8" Interchangeable Trim for 8A Slim Wafer Downlights; Matte black	843654139333	IKI-88
KT-WDLED-8A-BN-TRIM	8" Interchangeable Trim for 8A Slim Wafer Downlights; Brushed nickel	843654139364	JIH-47
KT-WDLED-8A-BR-TRIM	8" Interchangeable Trim for 8A Slim Wafer Downlights; Bronze	843654139395	QUD-62

Optional Accessories continued on next page

OPTIONAL ACCESSORIES (sold separately) (continued)

GOOF RING FOR LED SLIM WAFER DOWNLIGHTS

Dimensions

Size	D1 (Diameter 1)	D2 (Diameter 2)	H1 (Height 1)	H2 (Height 2)
4"	6.81"	4.21"	0.17"	0.10"
6"	8.88"	6.27"	0.17"	0.10"
8"	11.41"	8.11"	0.17"	0.10"

Installation

1. Slide goof ring over fixture.

2. Squeeze the two housing clips so they are in an upright position and then insert lamp into opening.

3. Once lamp is inside opening, release housing clips and continue to push lamp into opening until securely fixed and flush with ceiling.

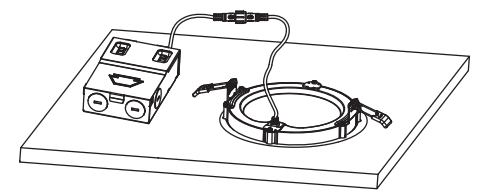
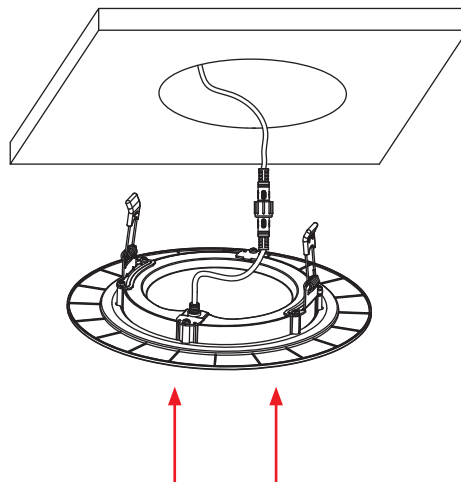
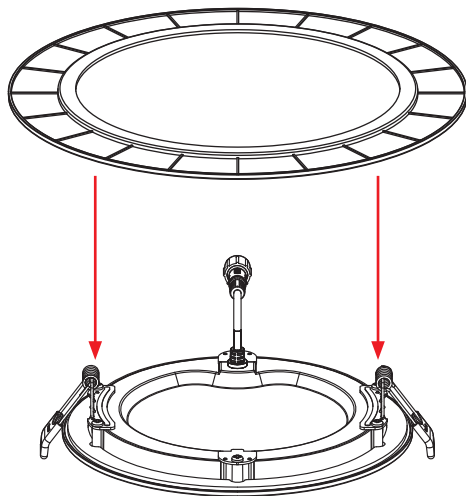

Ordering Information

Catalog Number	Description	UPC	Easy Code
KT-WDLED-4AB-GOOF	4" Goof Ring for 4A Slim Wafer Downlights; 6" outer diameter	843654139647	FRG-59
KT-WDLED-6AB-GOOF	6" Goof Ring for 6A Slim Wafer Downlights; 8" outer diameter	843654139654	MKE-35
KT-WDLED-8AB-GOOF	8" Goof Ring for 8A Slim Wafer Downlights; 10" outer diameter	843654139661	NTL-85

Optional Accessories continued on next page

OPTIONAL ACCESSORIES (sold separately) (continued)

NEW-CONSTRUCTION PLATE FOR LED SLIM WAFER DOWNLIGHTS

Dimensions

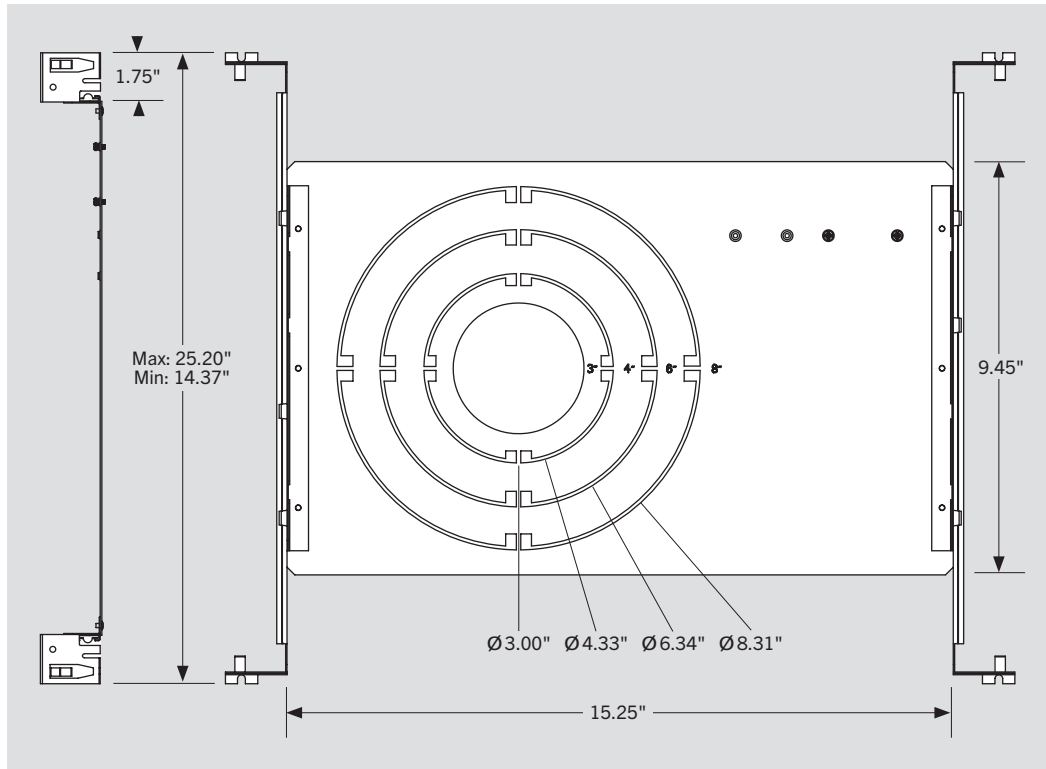

T-Grid Installation

1. Affix the brackets to the plate.

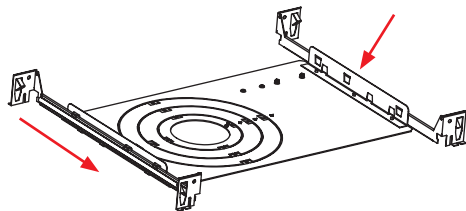

2. Use cutting pliers to remove any KO sections necessary to install the downlight.

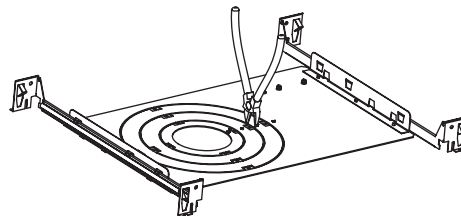

3. Secure J-box by placing it through the screws on the new construction plate.

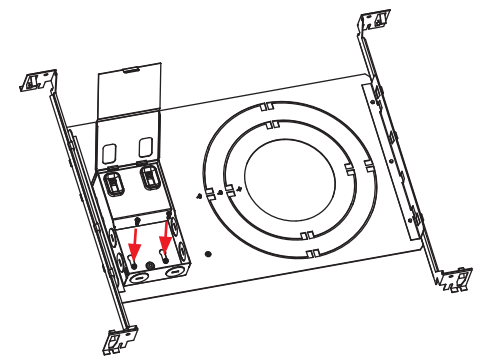

4. Bend end tabs so that brackets are straight.

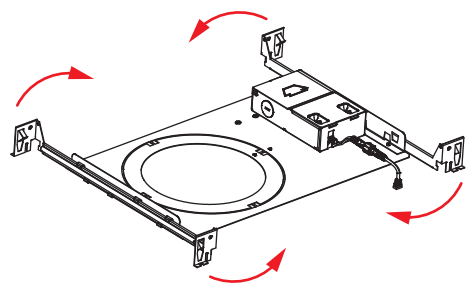

5. Rest 4 tabs over T-grid frame to secure plate in ceiling. Center construction plate over T-grid.

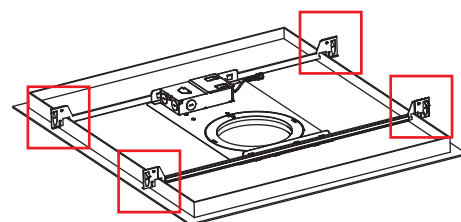

6. Once the plate is attached to the T-grid, cut a hole in the tile following the inside of the selected CKO. Follow appropriate downlight installation instructions to complete the installation.

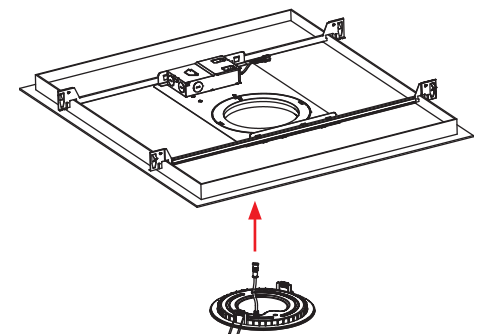

Optional Accessories continued on next page

OPTIONAL ACCESSORIES (sold separately) (continued)

NEW-CONSTRUCTION PLATE FOR LED SLIM WAFER DOWNLIGHTS (continued)

Ceiling Joist Installation

1. Affix the brackets to the plate.

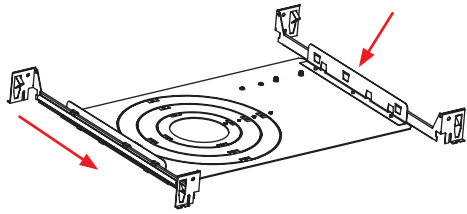

2. Use cutting pliers to remove any KO sections necessary to install the downlight.

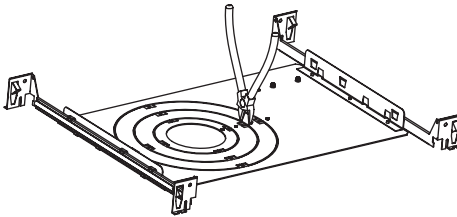

3. Secure J-box by placing it through the screws on the new construction plate.

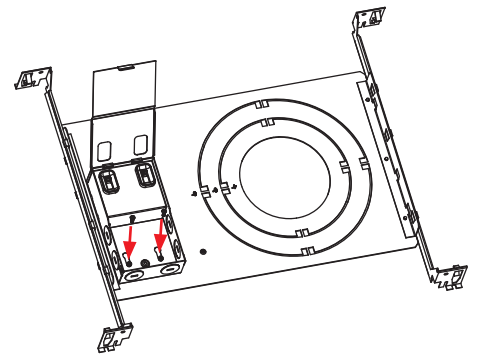

4. Place the plate between applicable joists where downlight will be installed; use a hammer to knock plate brackets into joists.

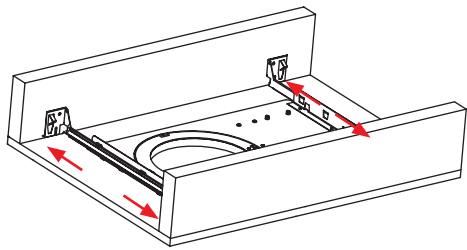

5. Once the plate is attached to joists, follow appropriate downlight installation instructions to complete the installation.

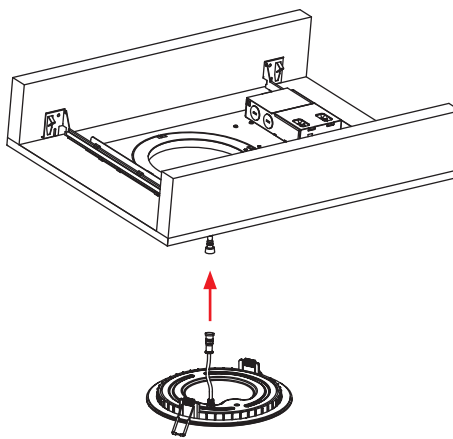

Ordering Information

Catalog Number	Description	UPC	Easy Code
KT-WDLED-PLATE-2	New-Construction Mounting Plate for 4A Slim Wafer Downlights; used for T-grid and ceiling joist installations	843654139791	FZT-71

Optional Accessories continued on next page

OPTIONAL ACCESSORIES (sold separately) (continued)

EXTENSION CABLES FOR LED SLIM WAFER DOWNLIGHTS

Dimensions

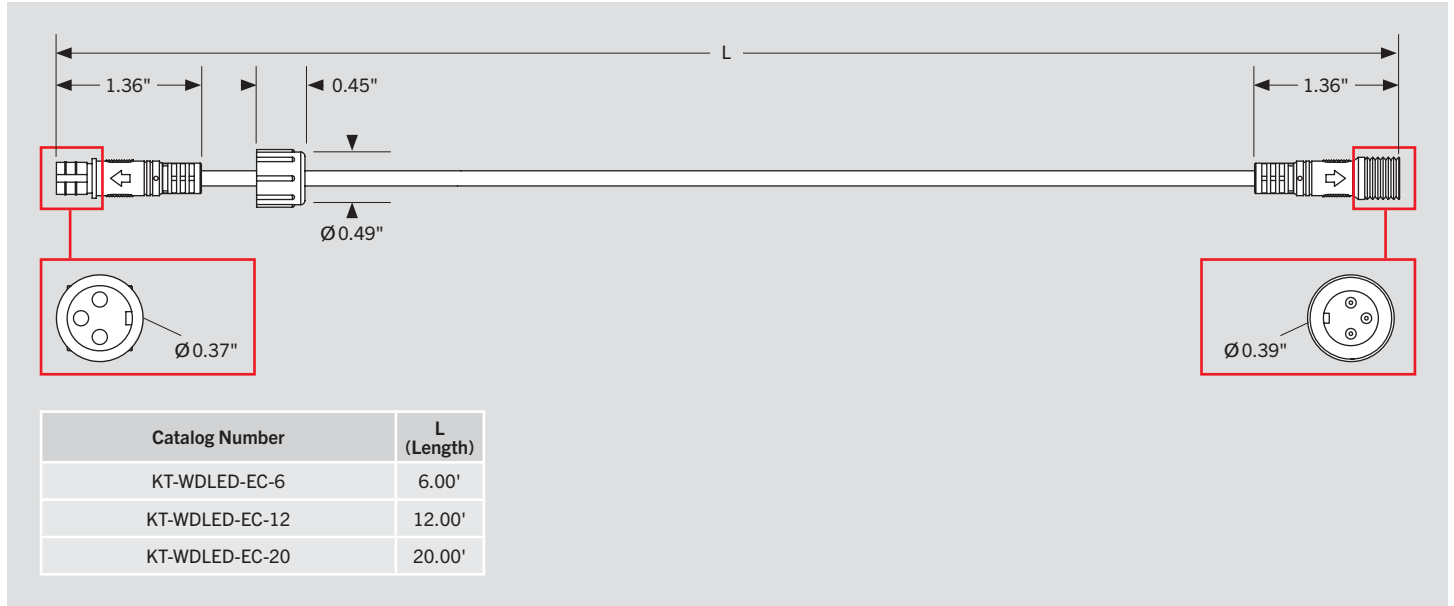

Ordering Information

Catalog Number	Description	UPC	Easy Code
KT-WDLED-EC-6	6' Extension Cord for all Wafer Downlights	843654139739	GOK-14
KT-WDLED-EC-12	12' Extension Cord for all Wafer Downlights	843654139746	ECE-88
KT-WDLED-EC-20	20' Extension Cord for all Wafer Downlights	843654139753	JLM-06

METAL-CLAD CABLE FOR LED SLIM WAFER DOWNLIGHTS

Dimensions

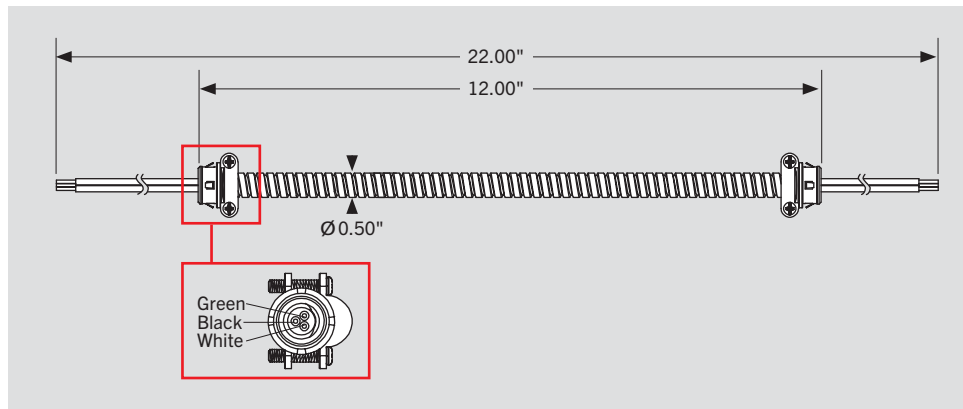

Ordering Information

Catalog Number	Description	UPC	Easy Code
KT-MC-NP-1-18/3	Metal-Clad Cable all Wafer Downlights; No plug; UL 16AWG 18/3 wire (live, neutral, ground)	843654139777	AYT-71

LED SLIM WAFER DOWNLIGHT ORDERING INFORMATION

Catalog Number	Pack Qty.	UPC	Easy Code
KT-WDLED10.5PS-4A-9CSF-VDIM	1	843654139180	NWX-68
KT-WDLED14PS-6A-9CSF-VDIM	1	843654139197	VDZ-85
KT-WDLED23PS-8A-9CSF-VDIM	1	843654139203	TSP-41