



Advance Xitanium range of phase-cut dimming LED drivers is perfectly suited for commercial fittings in downlight and track lighting applications. These models offer the flexibility of precise output of drive currents from selectable settings and are compatible with a variety of electronic low voltage dimmers to deliver reliably smooth dimming performance. The drivers are offered in a compact form factor suitable for use in elegantly unobtrusive fixture designs. Rated for long life with efficient performance, these drivers are excellent design choices for LED downlight fixtures and offer the benefits of long-lasting energy savings with low maintenance costs.

### Specifications

Input Voltage (Vrms)	Output Power (W)	Output Voltage (V)	Output Current (A)	Efficiency@ Max. Load and 70°C Case	Max. Case Temp. (°C)	Input Current (Arms)	Max. Input Power (W)	THD @ Max. Load	Power Factor @ Max. Load	Surge Protection Common/ Diff (KV)	Envir. Protection Rating
120	55	20-42	1.0-1.3	88	Life - 75°C Max. - 85°C	0.4	60	<15%	>0.95	2.5	UL Damp & Dry
277				87		0.19		<20%	>0.90		

### Enclosure

P can	In. (mm)
Case Length (L2)	3.74 (95)
Case Width (W)	2.75 (70)
Case Height (H)	1.26 (32)
Mounting Length (M)	3.35 (85)

### Wiring Diagram

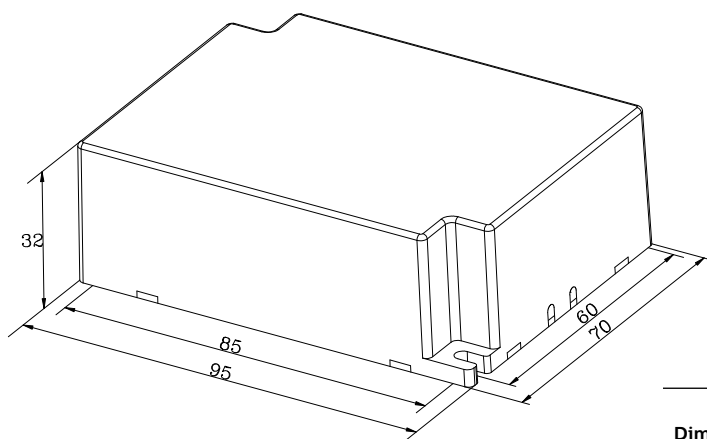
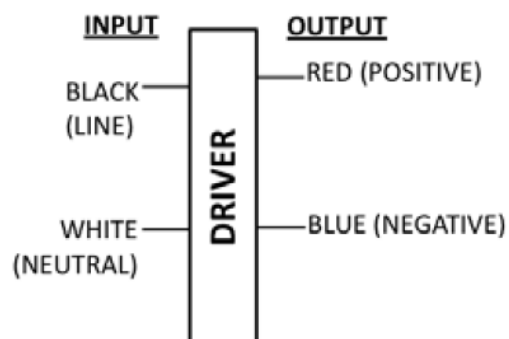

Input and output use lead wires.

Lead-wires are 18AWG 105C/600V stranded copper.

Standard lead length is 150mm (±10mm) on all wires outside the can.

All wires have tinned ends.

Dimming	Dimming Range	Minimum Output Current (A)	Other Comments
LE + TE Leading Edge & Trailing Edge	3.5% ~ 100%	0.035	Only @ 120V



Intertek  
Class P  
Conforms to UL STD 8750  
Certified to CAN/CSA STD  
C22.2 No. 250.13

LISTED  
E465448

# Xitanium XI055C130V042RNP1

## 55W 1.0-1.3A 42V LE+TE INT

### Features

- 50,000+ hour lifetime<sup>1</sup>
- UL Class 2 output with adjustable drive current
- Leading edge / Trailing edge dimming
- Compact form factor

### Benefits

- Enables easy design-in with excellent thermal performance
- Enables simple, fast, flexible application-specific configurations
- Enables light levels suited for the application
- Enables design of low profile fixtures

### Application

- Indoor downlight and track applications
- Retail
- Hospitality

### Electrical Specifications

All the specifications are typical and at 25°C Tcase unless specified otherwise.

### Product Data

Order Information	
Full Product Code	XI055C130V042RNP1M (Mid-Pack, 20pcs/Box), 12NC: 929000795513
Line Frequency	50/60Hz
Min. Mains Voltage Operational	108 Vac
Max. Mains Voltage Operational	305 Vac
Output Information	
Maximum Open Circuit Voltage	<60Vdc
Output Current Ripple	30% max. @ max. Iout
Output Current Tolerance (within full output operating range)	1000mA: (-8% / +5%) 1100mA: (-8% / +5%) 1200mA: (-8% / +5%) 1300mA: (-8% / +5%)  Output Current variation includes effects of line & load regulation, temperature variation and component tolerances
Protections	Short Circuit, Open Circuit Protection for LED + and LED - and Temperature Foldback
Features	
Dimming	LE + TE dimming
AOC (adjustable output current)	1000mA to 1300mA via DIP switches (refer to figure & notes in the Electrical Specification section)
Environment & Approbation	
Operating Ambient Temp. Range	-20°C to +50°C
Max. Case Temperature (Tcase)	Tcase Life: 75°C, Max. 85°C
Agency Approbations	UL8750, UL991, CSA250.13-14, C22.2 No. 0.8-12, Class P (UL, CSA, ETL)
Electromagnetic Compliance	FCC Title 47 Part 15 Class A
Audible Noise	<24dB Class A
Weight	0.758 Lbs / 0.344 kgs

1. Advance Xitanium LED drivers are manufactured to engineering standards correlating to a designed and average life expectancy of 50,000 hours of operation at maximum rated case temperature. Minimum 90% survivals based on MTTF modeling.

# Xitanium XI055C130V042RNP1

55W 1.0-1.3A 42V LE+TE INT

## Electrical Specifications

All the specifications are typical and at 25°C Tcase unless specified otherwise.

## LE + TE Dimming

Minimum Dim Level: 3.5% of Iout (minimum 35mA)

## Approved Dimmer List

Manufacturer	Manufacturer Part Number	Type of Dimmer	Min. Number of Drivers per Dimmer	Max. Number of Drivers per Dimmer
Lutron	DV-600P	Leading Edge	1	Dimmers can be loaded up to 80% of their max. power rating
	DVELV-303P	Trailing Edge		
	NTELV-600	Trailing Edge		
	MAELV-600	Trailing Edge		
	DVLV-600P	Leading Edge		
	SELV-300P	Leading Edge		
	NFTU-5A	Leading Edge		
	CTCL-153P	Leading Edge		
	GL-600H	Leading Edge		
	S-600P	Leading Edge		
	PHPM	277V		

# Xitanium XI055C130V042RNP1

55W 1.0-1.3A 42V LE+TE INT

## Electrical Specifications

All the specifications are typical and at 25°C Tcase unless specified otherwise.

## AOC (Adjustable Output Current) Settings:

The output current of the driver can be adjusted using the two dip switches provided on the bottom of the driver.

The below picture shows the switch positions required to set the current to different levels.

Switch 1	Switch 2	Drive Current
OFF	OFF	1000mA
OFF	ON	1100mA
ON	OFF	1200mA
ON	ON	1300mA (factory default)

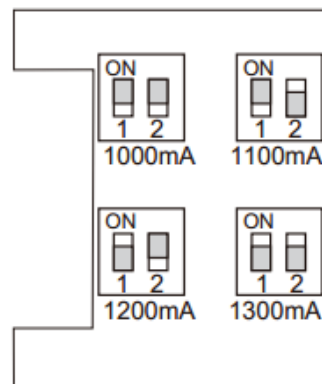

## Notes

The driver will be shipped out of factory with a default of 1300mA

# Xitanium XI055C130V042RNP1

55W 1.0-1.3A 42V LE+TE INT

## Electrical Specifications

All the specifications are typical and at 25°C Tcase unless specified otherwise.

## Output Current Vs. Driver Case Temperature

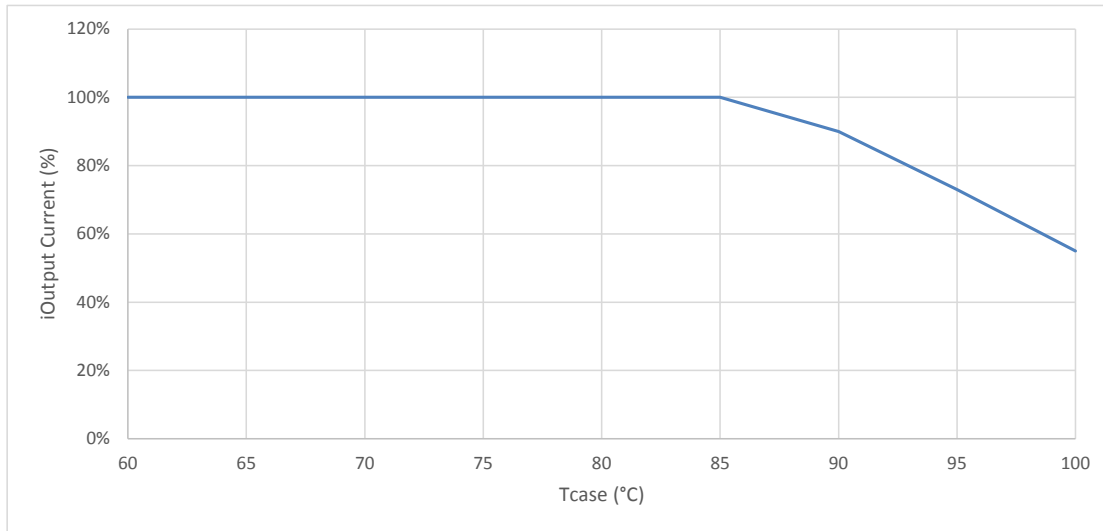

## Note

There is  $\pm 5^\circ\text{C}$  tolerance on the driver case temperature.

## Driver Lifetime Vs. Driver Case Temperature

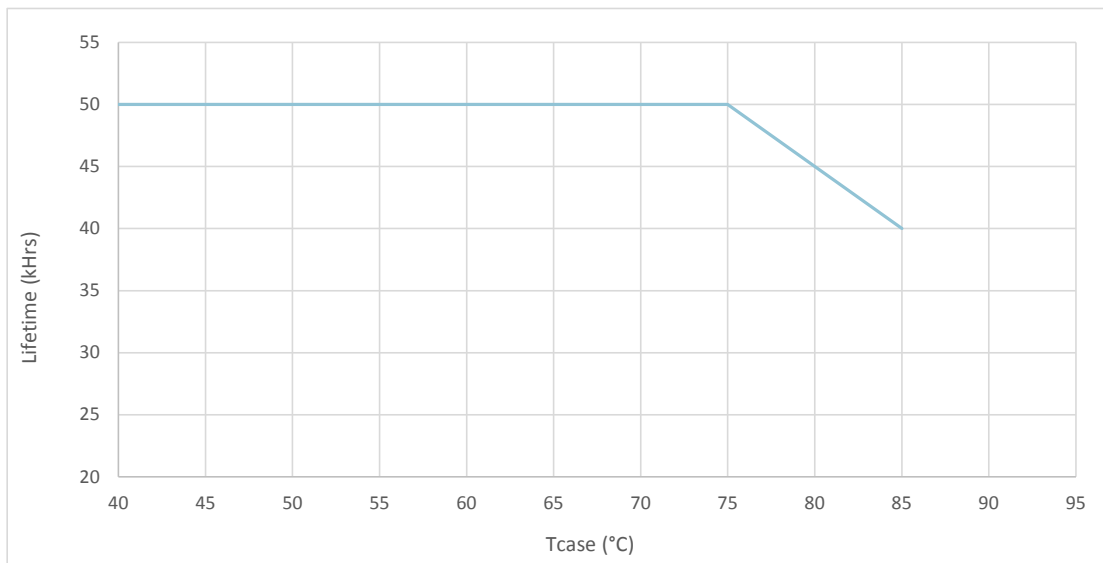

# Xitanium XI055C130V042RNP1

55W 1.0-1.3A 42V LE+TE INT

## Performance Characteristics

Based on measurements on a typical sample at 75°C case. The accuracy of the measurements is within the tolerance of the measurement instruments.

### Efficiency Vs. Output Voltage at 120Vac

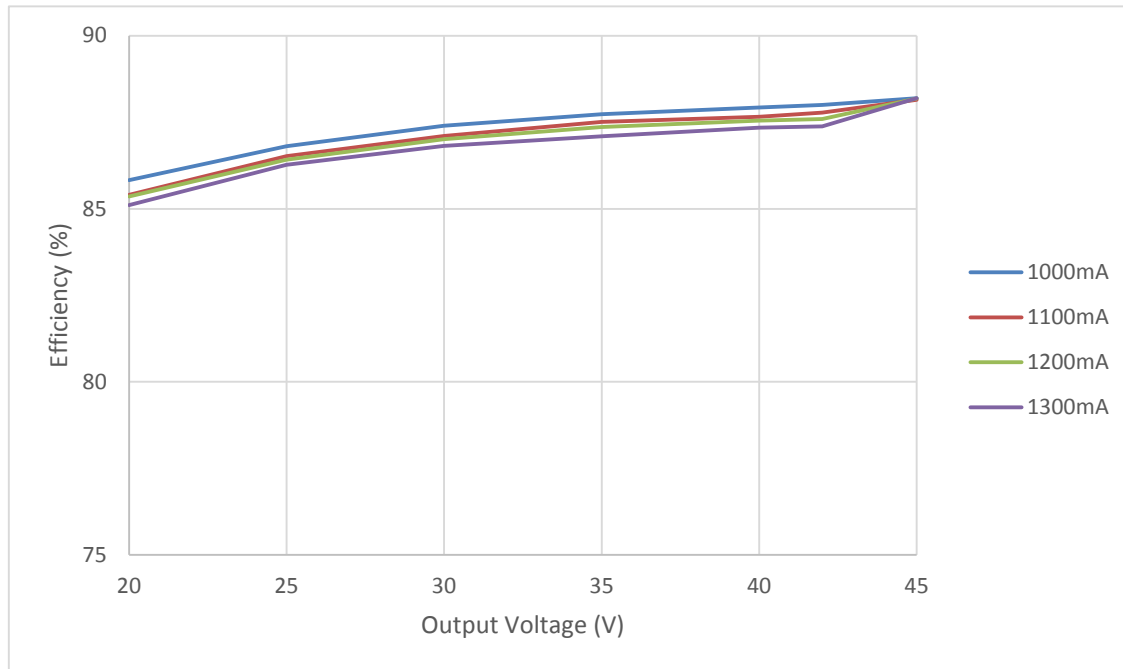

### Efficiency Vs. Output Voltage at 277Vac

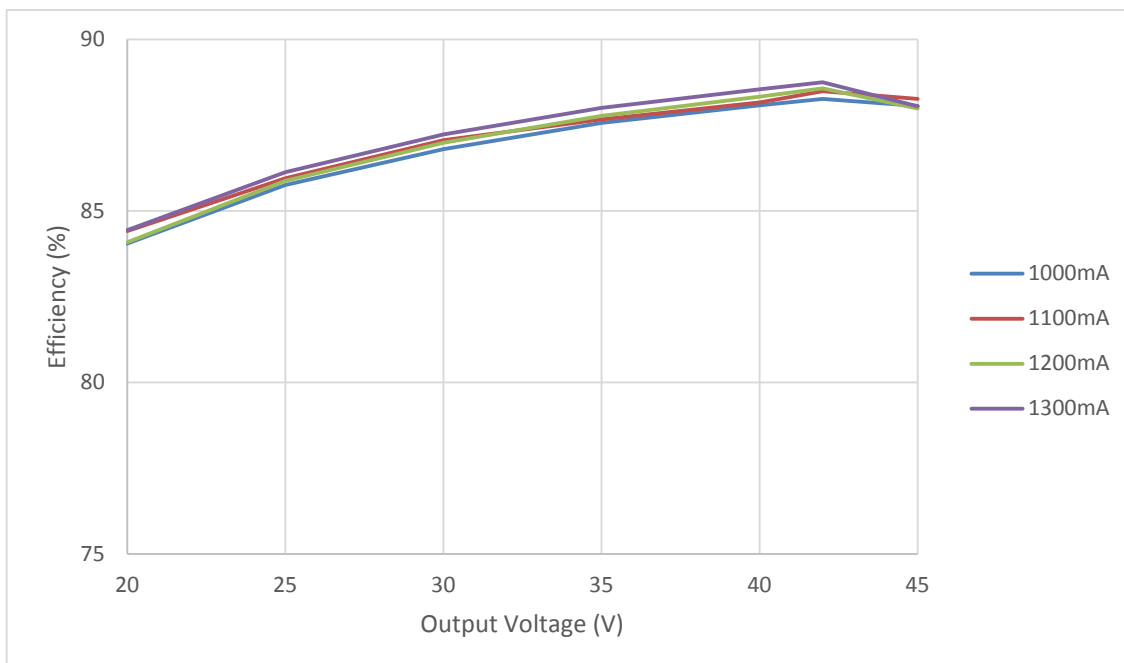

# Xitanium XI055C130V042RNP1

55W 1.0-1.3A 42V LE+TE INT

## Performance Characteristics

Based on measurements on a typical sample at 75°C case. The accuracy of the measurements is within the tolerance of the measurement instruments.

### Power Factor Vs. Output Power at 500mA

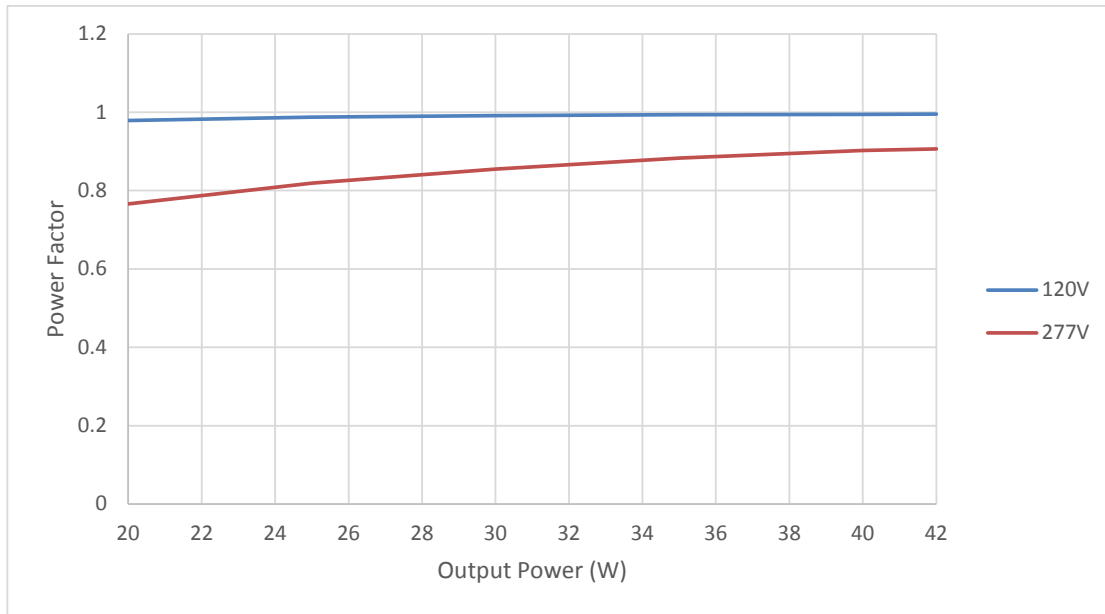

### Power Factor Vs. Output Power at 800mA

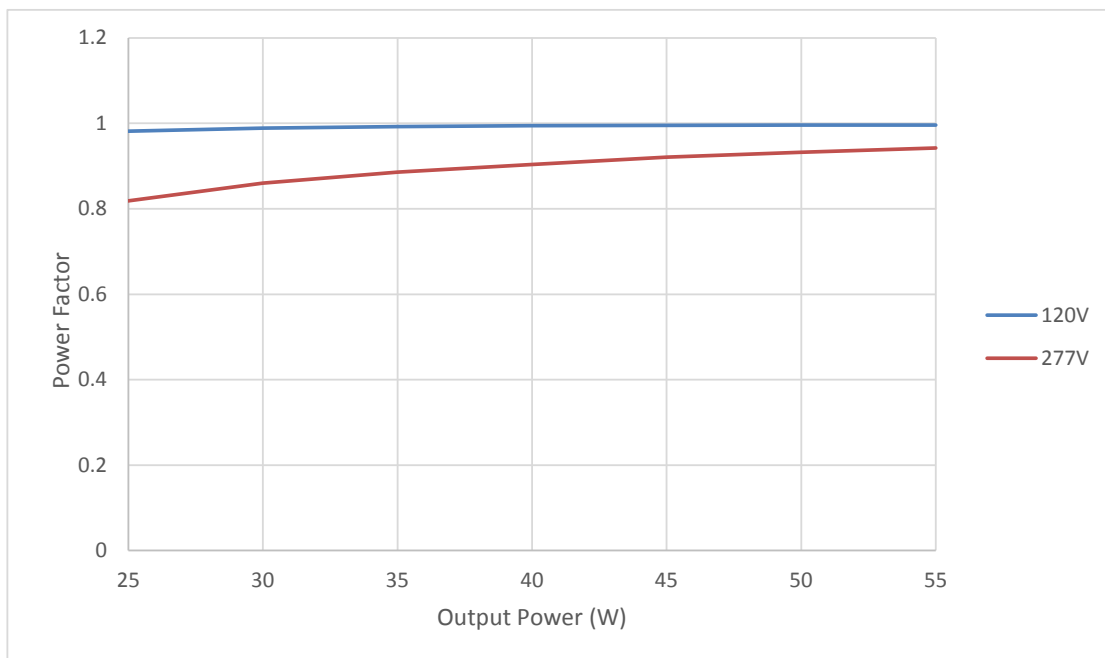

# Xitanium XI055C130V042RNP1

55W 1.0-1.3A 42V LE+TE INT

## Total Harmonic Distortion (THD) Vs. Output Power

Based on measurements on a typical sample at 75°C case. The accuracy of the measurements is within the tolerance of the measurement instruments.

### THD Vs. Output Power at 500mA

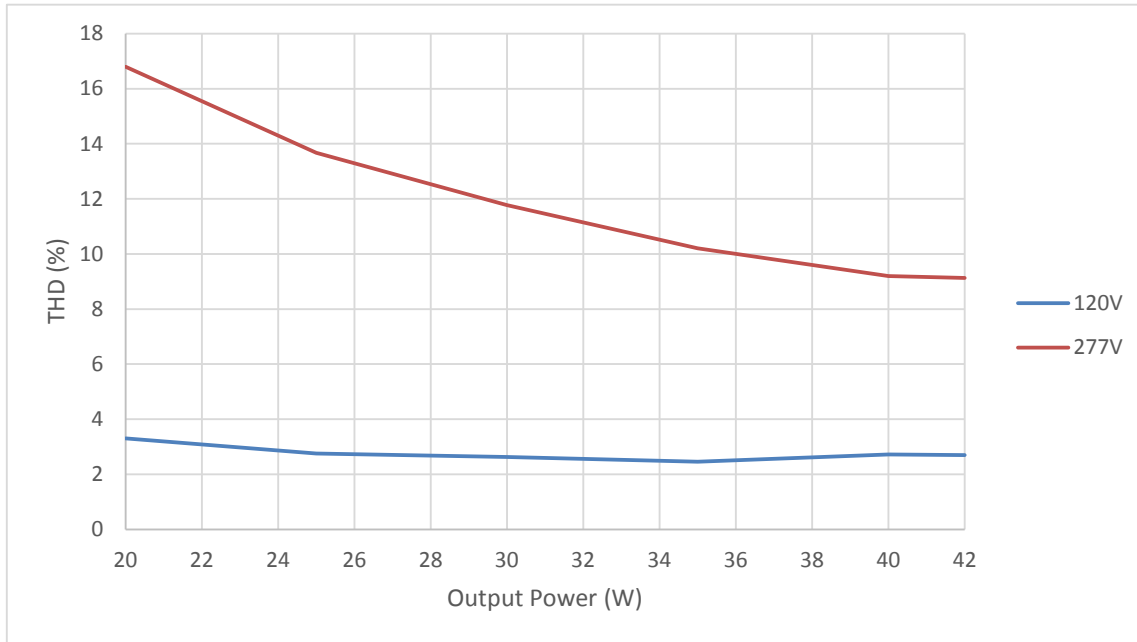

### THD Vs. Output Power at 800mA

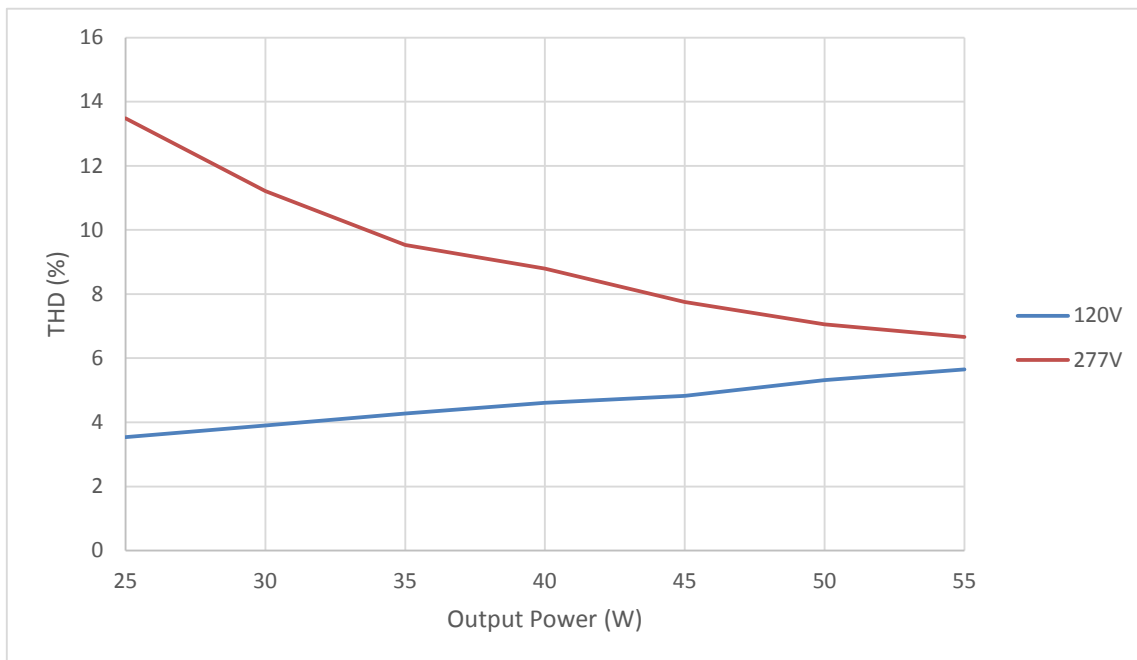



# Xitanium XI055C130V042RNP1

55W 1.0-1.3A 42V LE+TE INT

## Inrush Current Info

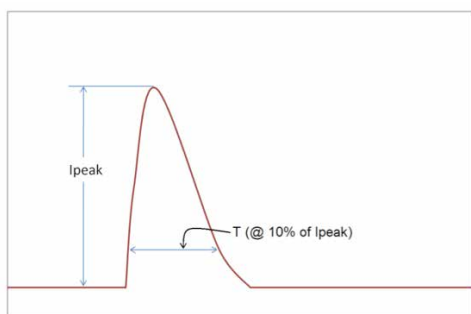

Vin	Ipeak	T (@ 10% of Ipeak)
120 Vac	1.25A	250µs
277 Vac	1.80A	420µs

Inrush current is measured at peak of the corresponding line voltage, source impedance per NEMA 410.

## Lightning Surge Info

ANSI Surge Type	Differential Mode (L-N)
100K Hz Ring Wave (w/t 30Ω)	2.5kV

## Isolation

Isolation	Input	Output
Input	NA	2xU+1kV
Output	2xU+1kV	NA

U=Max. working voltage

