



KT-EMRG-LED-12-1200-AC

CONSTANT WATTAGE LED EMERGENCY BACK-UP DRIVER

DESCRIPTION

LED Emergency Back-Up Driver | Standard Side-Exit Wire Leads | 12W Output



DRIVER TYPE: Constant Wattage LED Emergency
MAX. OUTPUT POWER: 12W
INPUT VOLTAGE: 120–277Vac ±10%
OUTPUT VOLTAGE: 40–100Vdc
OUTPUT CURRENT: Load Dependent
WARRANTY: 5 Years



PRODUCT FEATURES

- Optimized for Keystone single-ended direct drive LED tubes. Contact Keystone for details on functioning with other Type B LED tubes
- Illuminates entire LED load at reduced output under emergency mode
- One-piece design with metal housing
- 2-in-1 LED test switch and indicator light included
- Not for use with dimmers
- Evaluated to UL 924 requirements
- 90-minute operation in emergency mode
- UL listed
- Operating temperature: 0°C/32°F to 50°C/122°F
- Input frequency: 50/60 Hz
- Safety Standard: UL 924, Complies with CEC Title 20 Efficiency Standards
- Li(NiCoMn)O₂ Battery

ELECTRICAL SPECIFICATIONS

Family	INPUT CHARACTERISTICS			OUTPUT CHARACTERISTICS			
	Input Voltage	Power Factor	Max. Current	Max. Output Power	Rated Output Current	Output Voltage	Output Current
12W	120–277Vac	≥ 0.35	100mA @120V	10–12W	Load Dependent	40~100Vdc	200–750mA

Emergency pack designed to deliver 12W to a constant current LED load. Approximate output is 1200 lumens, assuming a nominal minimum efficacy of 100lm/W.

PHYSICAL SPECIFICATIONS

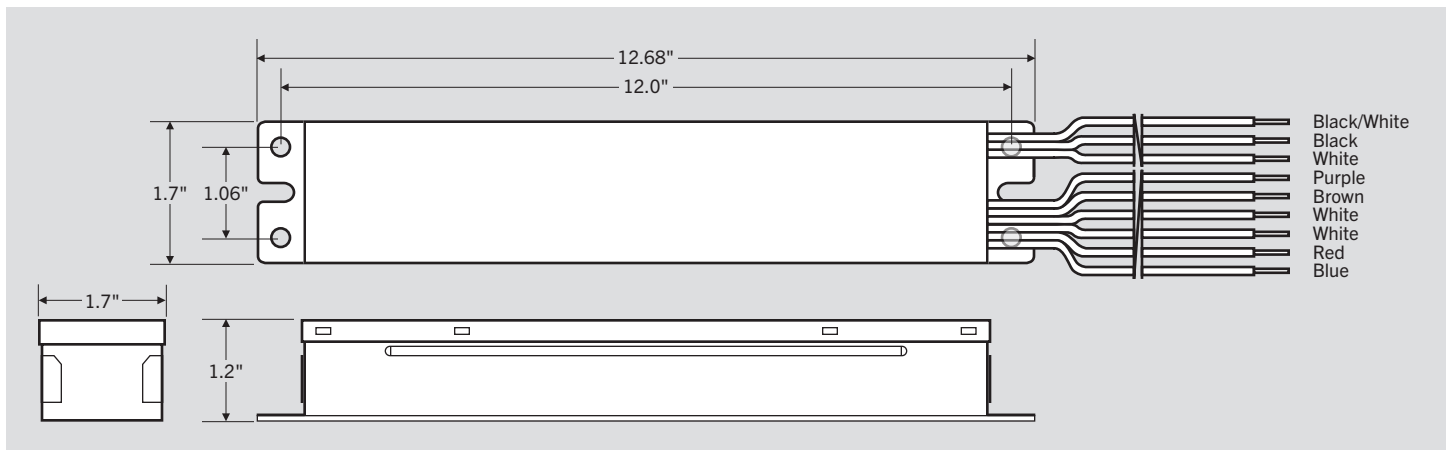



KT-EMRG-LED-12-1200-AC

CONSTANT WATTAGE LED EMERGENCY BACK-UP DRIVER

WIRING DIAGRAM

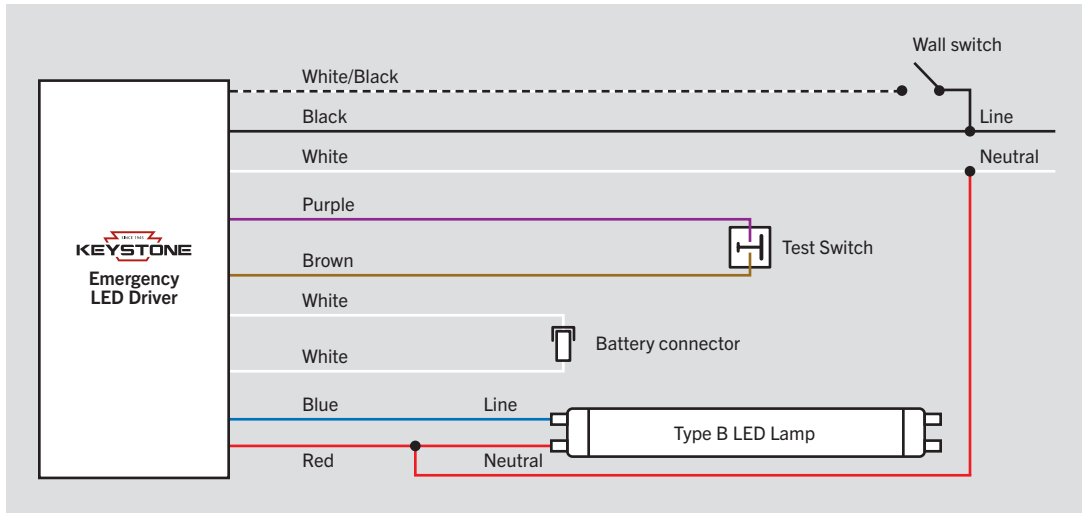

Wire Specifications

Wire Color	Wire Length	
	mm	Inches
Black/White	650 mm	25.60"
Black	800 mm	31.50"
White	800 mm	31.50"
Purple	1,200 mm	47.25"
Brown	1,200 mm	47.25"
White	320 mm	12.60"
White	320 mm	12.60"
Blue	1,200 mm	47.25"
Red	1,200 mm	47.25"

Wiring for Double Ended Lamps

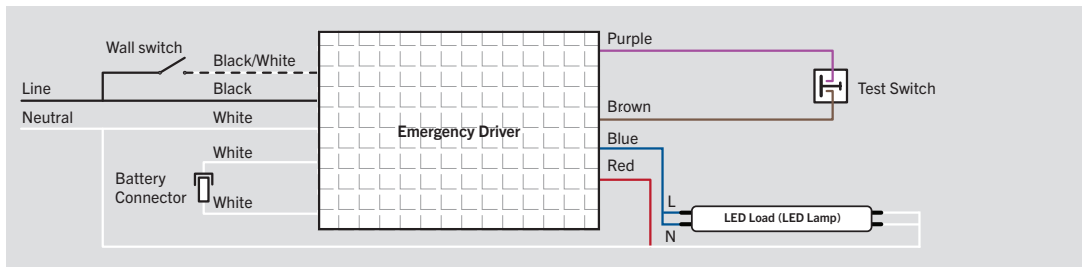

ORDERING INFORMATION

ORDER CODE	DESCRIPTION	PACKAGING STYLE	PACK QTY.	ITEM STATUS
KT-EMRG-LED-12-1200-AC	1-Piece LED Emergency Back-Up with Standard Side-Exit Wire Leads	Individually Packaged	1	Active

CATALOG NUMBER BREAKDOWN

KT-EMRG-LED-12-1200-AC-IP

1
2
3
4
5
6
7

- 1 Keystone Technologies
- 2 Emergency Back-Up Driver
- 3 LED Driver
- 4 Wattage Family
- 5 Nominal Lumen Output
- 6 Alternating Current
- 7 Packaging Style