

PrimaPanel Flexible LED Sheet

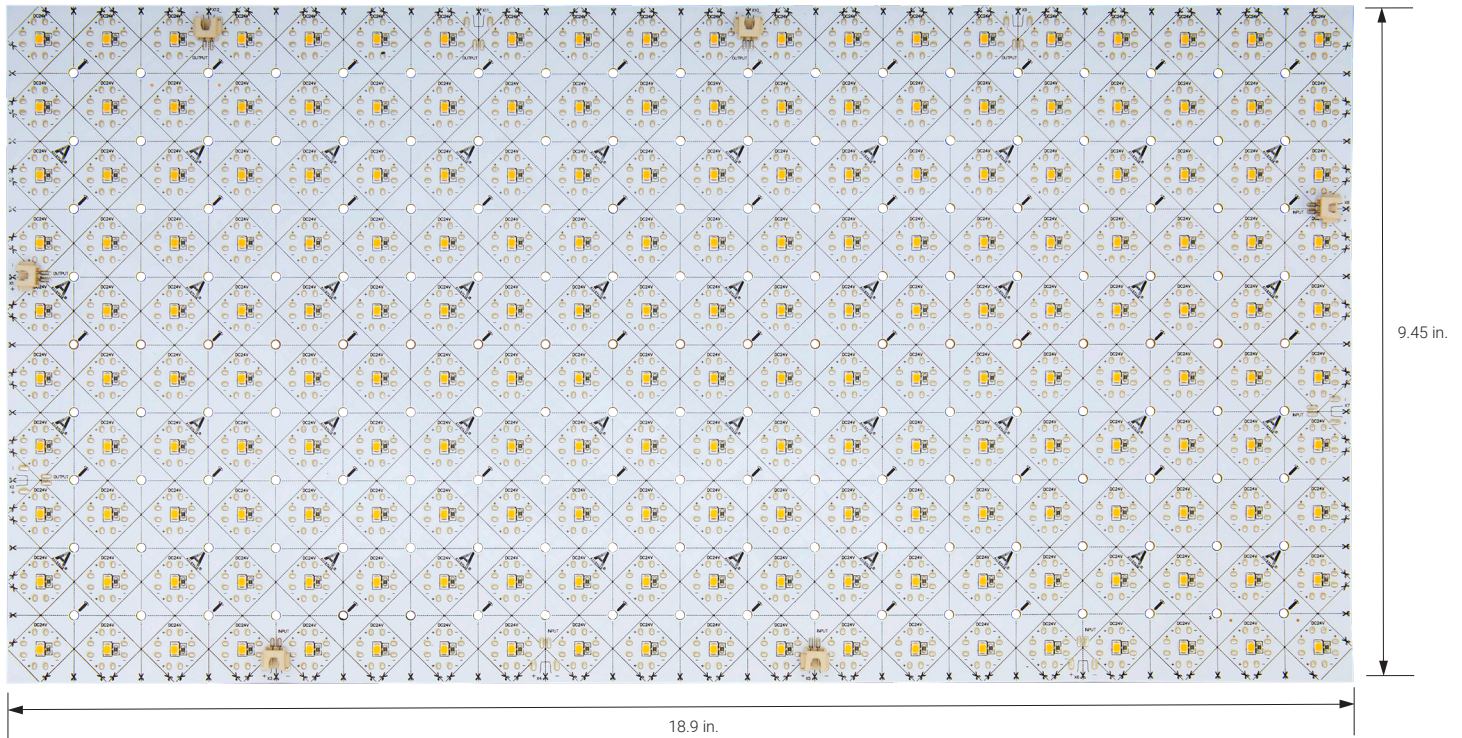

The PrimaPanel LED Sheet is a fully modular, flexible, water-proof and cuttable LED sheet for backlighting applications such as displays, translucent materials, showcases and more. The LED sheet can create a hotspot-free look and offers easy installation with 3M™ adhesive tape or by using nails or screws at the designated areas on the sheet.

- High density of LED chips contributes to a smooth distribution of light
- Can be cut vertically, horizontally or at a 45° angle
- High CRI of 95+ (3000K-5000K) and 89+ (6500K) for excellent color rendering
- Includes two 3-inch jumper cables, two 6-inch hardwire cables, and six screws
- Acrylic standoffs are available for purchase to create space between the PrimaPanel and overlaying material to ensure even illumination and protection

TECHNICAL INFORMATION

Color Temperature	3000K, 4000K, 5000K, 6500K	Dimmable	Yes
Power Consumption per Sheet	16.6 Watts	Diode Type	2835 SMD
Current per Sheet	691 mA	Mounting	Screws, nails and 3M™ VHB™ Adhesive Backing
Input Voltage	24V DC	Operating Temperature	-13° F to 140° F
Diodes per Sheet	200	Ambient Temperature	-13° F to 158° F
Diode Spacing	0.94 inches	Environment	Indoor, Outdoor (IP64)
Sheet Height	0.07 inches	Sheet Dimensions (LxWxH)	18.9 x 9.45 x 0.07 in.
Beam Angle	120°	Certifications	UL Listed
Minimum Cutting Size	0.94 x 0.94 in. (Horizontal/Vertical) 0.67 x 0.67 in. (Diagonal)	Warranty	6 Year Limited
Maximum Number of Daisy-chained Sheets	7 sheets		

PRODUCT INFORMATION

Item Number	Voltage	Color Temperature	CRI	R9 Values	R13 Values	TM30	CQS	Lumens per Sheet
AL-01-90-2402	24V DC	3000K	95.3	67.1	96.5	91.9	91.6	1269
AL-01-90-2403	24V DC	4000K	96.2	95.3	97.7	90.7	93.8	1313
AL-01-90-2404	24V DC	5000K	95.6	97.7	97.8	91.0	93.2	1293
AL-01-90-2409	24V DC	6500K	89.6	82.0	91.6	84.3	90.0	1309

ACCESSORIES

Includes two 3-inch jumper cables, two 6-inch hardwire cables, and six screws. Additional cables and acrylic standoffs are available for purchase.

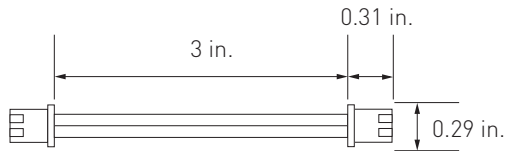

Jumper Cable - 3 in.

AL-01-90-9902



6 Screws

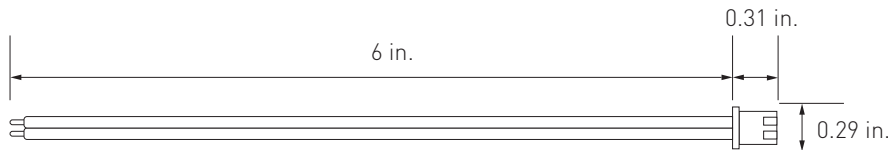

Hardwire Power Cable - 6 in.

AL-01-90-9908

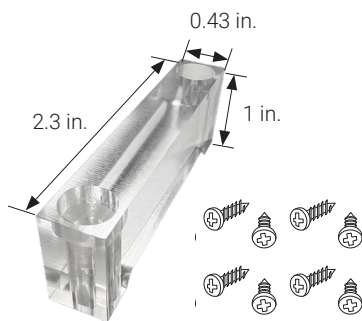

Acrylic Standoff - Pack of 4 - 1 in.

8 screws

AL-01-90-99STND100-4

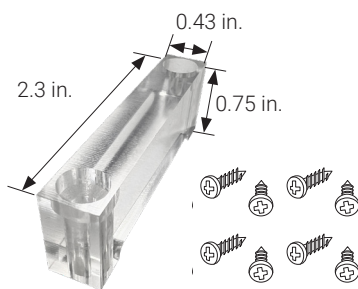

Acrylic Standoff - Pack of 4 - 0.75 in.

8 screws

AL-01-90-99STND075-4

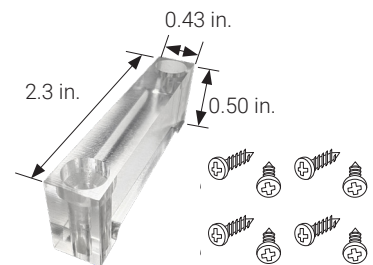

Acrylic Standoff - Pack of 4 - 0.5 in.

8 screws

AL-01-90-99STND050-4

ALLOY LED[®] Specifications

RECOMMENDED POWER SUPPLIES (SOLD SEPARATELY)



Alloy LED PowerFactor™ Dimmable Power Supplies w/ Integrated UL Listed Junction Box
Compact, highly efficient, and code-compliant power supply with versatile and smooth dimming capabilities.

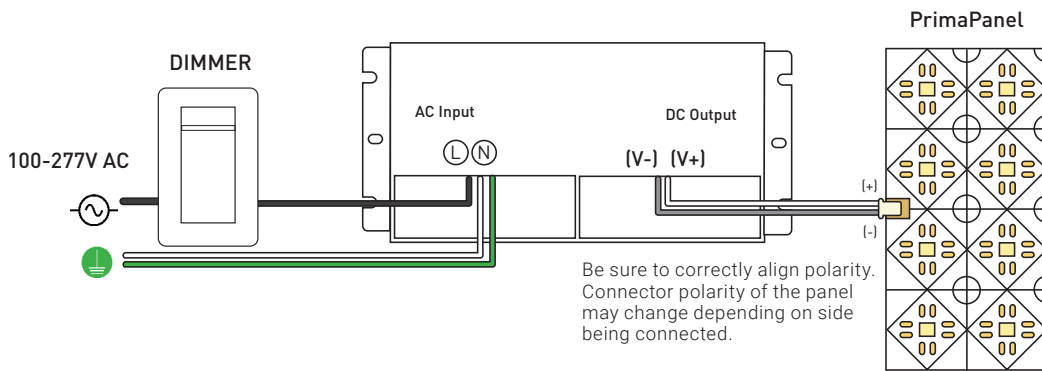

Wiring diagram is for reference ONLY. Please refer to dimmer wiring specifications sheet for accurate directions.

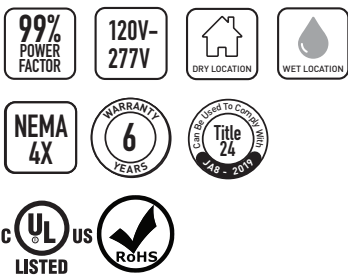

Single Tap Models

Item Number	Output Voltage	Wattage	Wet Location	Minimum Load	Dimensions (L x W x H)	Class 2
AL-98-10-24030	24V DC	30W	Yes (NEMA 4X)	10%	6.50 x 3.72 x 1.02 in.	Yes
AL-98-10-24060	24V DC	60W	Yes (NEMA 4X)	10%	7.40 x 3.72 x 1.02 in.	Yes
AL-98-10-24096	24V DC	96W	Yes (NEMA 4X)	10%	8.66 x 3.72 x 1.57 in.	Yes
AL-98-10-24150	24V DC	150W	Yes (NEMA 4X)	10%	10.24 x 4.13 x 1.77 in.	No
AL-98-10-24200	24V DC	200W	Yes (NEMA 4X)	10%	10.24 x 4.13 x 1.77 in.	No
AL-98-10-24300	24V DC	300W	Yes (NEMA 4X)	10%	10.94 x 4.33 x 1.77 in.	No

Class 2 Compliant Multi-Tap Models

Item Number	Output Voltage	Wattage	Wet Location	Minimum Load	Dimensions (L x W x H)	Class 2
AL-98-10-24192-MT	24V DC	192W	Yes (NEMA 4X)	10%	10.94 x 4.33 x 1.77 in.	Yes
AL-98-10-24288-MT	24V DC	288W	Yes (NEMA 4X)	10%	10.85 x 4.33 x 1.77 in.	Yes

Note: PowerFactor assumes 80% load.
Inspectors prefer power supply to be used with junction box.
For dimmer compatibility, refer to drivers specification sheet.

ALLOY LED® Specifications

RECOMMENDED POWER SUPPLIES (SOLD SEPARATELY)

Alloy LED Primavolt® No Minimum Load Dimmable Power Supplies w/ETL Listed Junction Box
Code-compliant power supply with versatile and smooth dimming capabilities. Compatible with ELV, MLV, and TRIAC dimmers.



White model for 60W and lower



Black model for 80W and higher

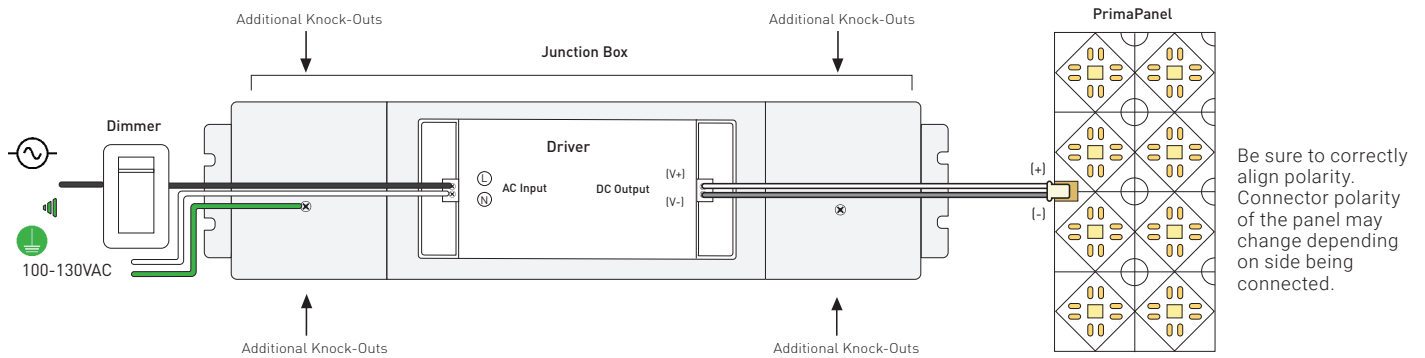

Wiring diagram is for reference ONLY. Please refer to dimmer wiring specifications sheet for accurate directions.



Item Number	Output Voltage	Wattage	Minimum Load	Dimensions (Junction box) (L x W x H)	Class 2
AL-98-03-24024-NM	24V DC	24W	0%	13.77 x 3.03 x 1.45 in.	Yes
AL-98-03-24048-NM	24V DC	48W	0%	13.77 x 3.03 x 1.45 in.	Yes
AL-98-03-24060-NM	24V DC	60W	0%	13.77 x 3.03 x 1.45 in.	Yes
AL-98-03-24080-NM	24V DC	80W	0%	14.96 x 3.03 x 2.24 in.	Yes
AL-98-03-24096-NM	24V DC	96W	0%	14.96 x 3.03 x 2.24 in.	Yes
AL-98-03-24150-NM	24V DC	150W	0%	15.98 x 3.42 x 2.36 in.	No
AL-98-03-24200-NM	24V DC	200W	0%	15.98 x 3.42 x 2.36 in.	No

Note: Alloy LED strongly recommends using Listed Class 2 power supplies for all installations. Always install in accordance with local and national electrical code regulations. Inspectors prefer power supply to be used with junction box. For dimmer compatibility, refer to drivers specification sheet.

ALLOY LED® Specifications

RECOMMENDED POWER SUPPLIES (SOLD SEPARATELY)

ELV Dimmable Power Supplies for Remote Enclosures

The drivers are derated, but when installed in a small enclosure with no heatsink or air circulation, we recommend a maximum load of 40W.

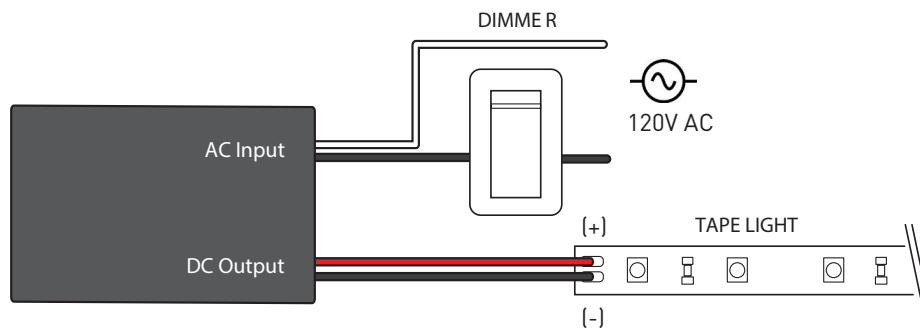

Wiring diagram is for reference only. Please refer to dimmer wiring specifications sheet for accurate directions.

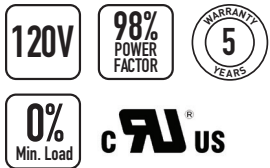

Item Number	Output	Wattage	Dimensions (L x W x H)	Class 2
AL-98-08-12060	12V DC	60W	2.66 x 1.30 x 0.83 in.	Yes
AL-98-08-24060	24V DC	60W	2.66 x 1.30 x 0.83 in.	Yes

Note: Inspectors prefer power supply to be used with junction box.
For dimmer compatibility, refer to drivers specification sheet.

ALLOY LED® Specifications

DIMMING ACCESSORIES (SOLD SEPARATELY)

Lutron® Dimming Accessories

By participating in Lutron's OEM Advantage program, Alloy LED is able to offer a range of the highest quality low voltage power supplies and selected controls on the market.



Hi-lume Premier
0.1% EcoSystem /
3-wire LED Driver
(96W 24VDC)



Hi-lume 1% LED Driver 40W
- EcoSystem / 3-wire control
- 2-wire 120V forward
phase control



Lutron Vive PowPak RF Module
- RF module for EcoSystem LED
driver control
- Use with the Lutron EcoSystem
drivers shown to "Vive-enable"
Alloy LED products

Lutron® Hi-lume LED Drivers

Item Number	Output	Wattage	Minimum Load	Class 2
AL-98-07-24040	24V DC	40W	N/A	Yes
AL-98-07-24040-3WIRE	24V DC	40W	N/A	Yes
AL-98-07-24096-3WIRE	24V DC	96W	N/A	Yes

Lutron® Controls

Item Number	Description	Voltage
AL-98-07-9901	EcoSystem Control Module	N/A
AL-98-07-9901-8	EcoSystem Control Module - 8 pack	N/A
AL-98-07-9950	CL Dimmer	120V AC
AL-98-07-9950-FPLATE	CL Dimmer faceplate	N/A

DIMMING ACCESSORIES (SOLD SEPARATELY)

Dimmers & Switches

SlimDim Wireless Dimmers

Using long-range RF technology, these LED dimmers connect wirelessly to a receiver, offering freedom to mount anywhere. Can also be used as a fob for mobile, hand-held control.

AL-70-01-0001	SlimDim Wireless Dimmer	
AL-70-01-0002	Single Color Receiver (96W max.) (sold separately)	
AL-98-07-9950-FPLATE	SlimDim Wall Plate (sold separately)	

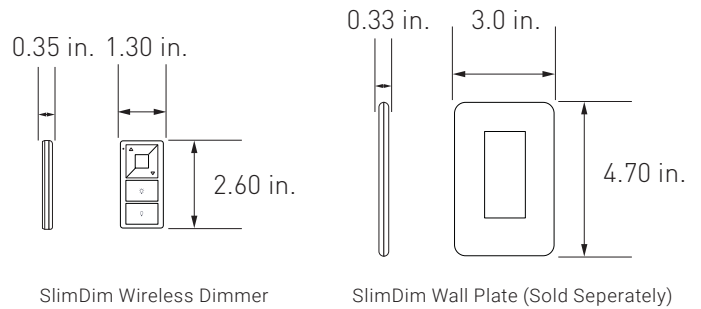

Remote Control Dimmer Switch

Provides full dimming and on/off control, and includes a touch wheel that allows for direct visual selection of brightness. It can also operate up to four independent zones.

AL-60-03-0001	Remote Control Dimmer Switch	
AL-70-01-0002	Single Channel Receiver (sold separately)	
AL-60-03-0004-V2	Wireless Receiver (RGB & RGB-W) (sold separately)	

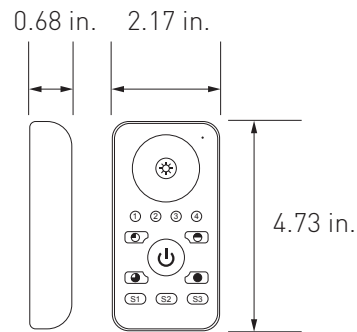

Single Channel Wireless Receiver

Pair with the Remote Control Dimmer Switch or the SlimDim Wireless Dimmer to dim PrimaLine tape lights. Use one remote to make independent lighting zones with multiple receivers with certain controllers.

AL-70-01-0002	Single Channel Wireless Receiver
---------------	----------------------------------

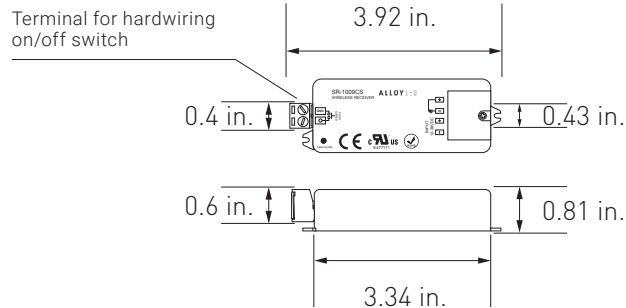

WIRING DIAGRAM

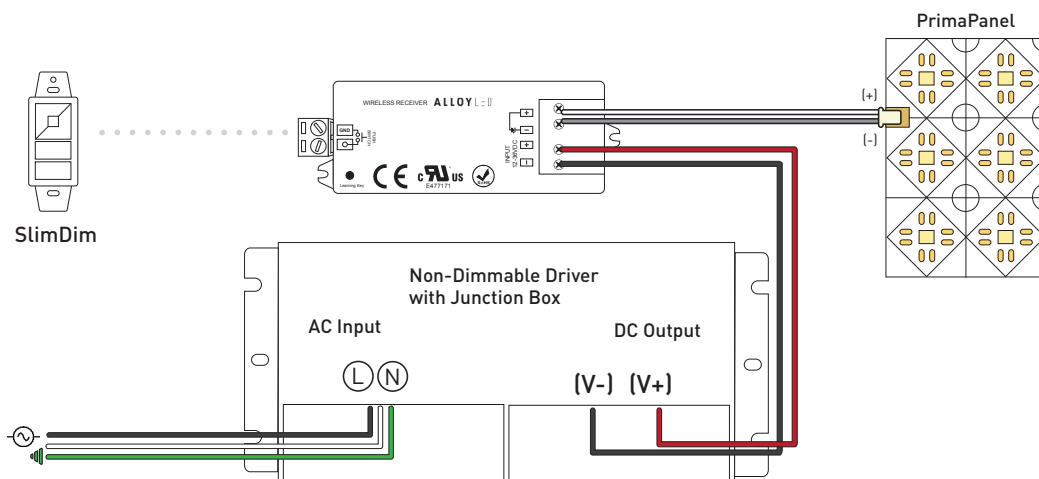

ALLOY LED® Specifications

RECOMMENDED POWER SUPPLIES (SOLD SEPARATELY)

Alloy LED TRIAC/MLV/ELV Dimmable Drivers for Remote Locations

Offers stable power in even in the most remote settings. Compatibility with TRIAC, ELV, or MLV dimmers.

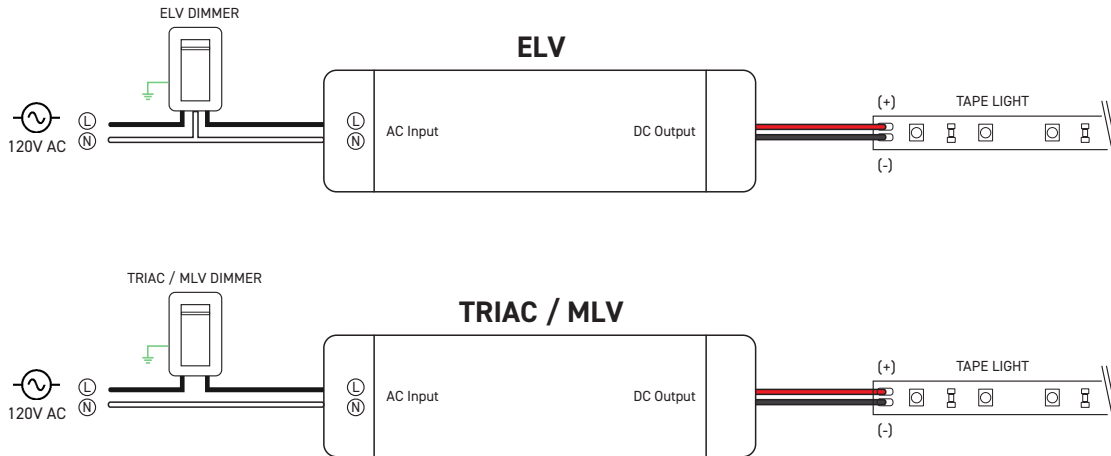

Wiring diagram is for reference only. Please refer to dimmer wiring specifications sheet for accurate directions.

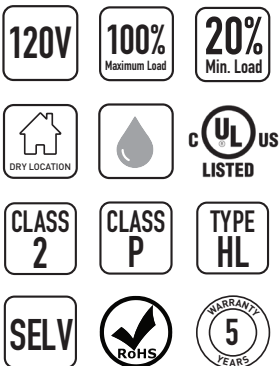

Item Number	Output Voltage	Wattage	Dimensions (L x W x H)	Class 2
AL-98-09-12060	12V DC	60W	3.31 x 1.57 x 0.98	Yes
AL-98-09-24096	24V DC	96W	3.31 x 1.57 x 0.98	Yes

Note: Alloy LED strongly recommends using Listed Class 2 power supplies for all installations. Always install in accordance with local and national electrical code regulations. Inspectors prefer power supply to be used with junction box. For dimmer compatibility, refer to drivers specification sheet.

Note: specifications are representative of the diode type and not a particular tape light article.

3000K

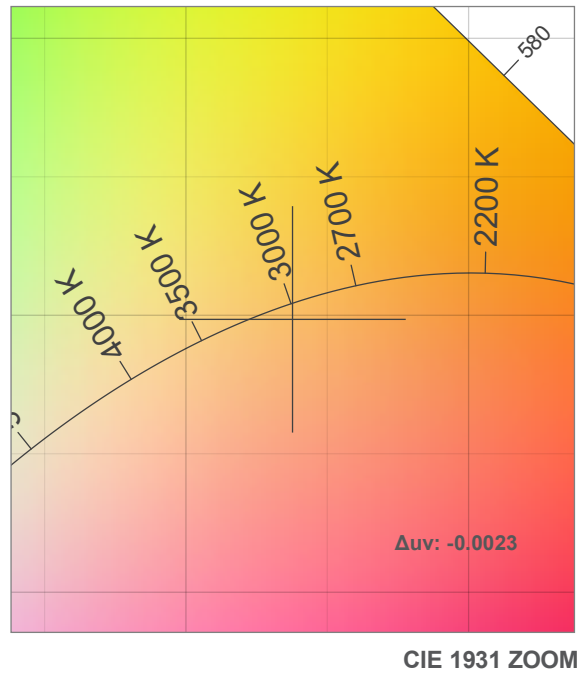
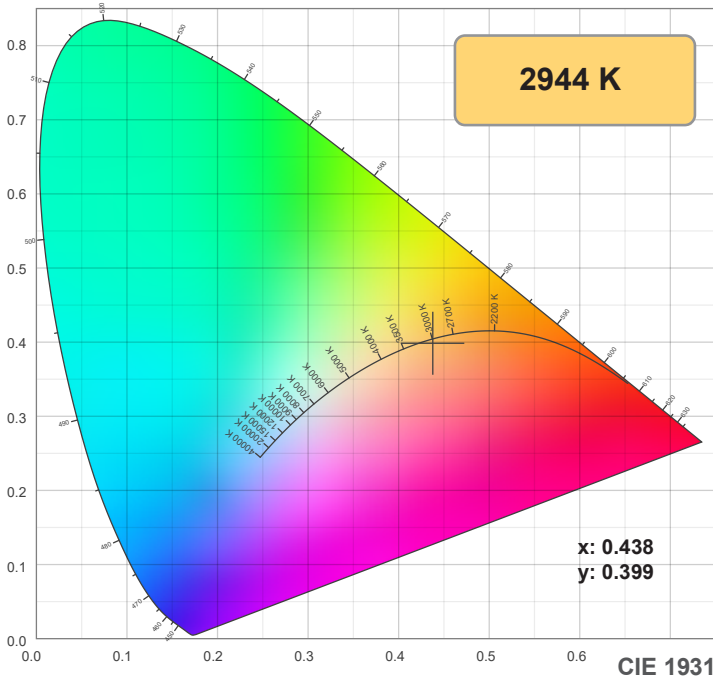

TM-30: 91.6

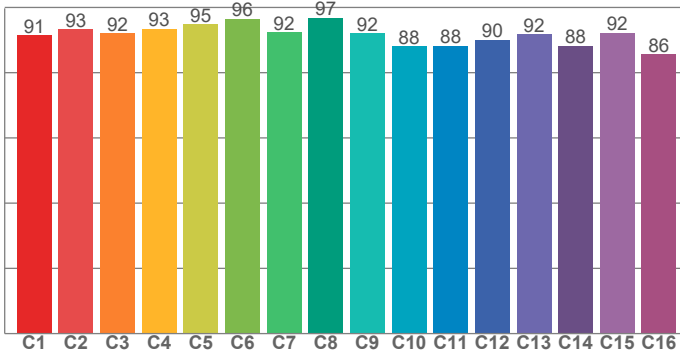

CRI: 94.4 (R1-R8)

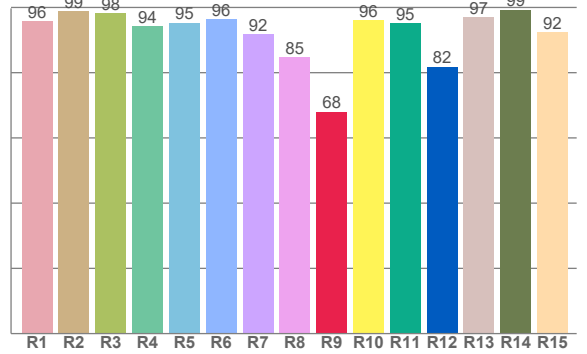

CQS: 91.5

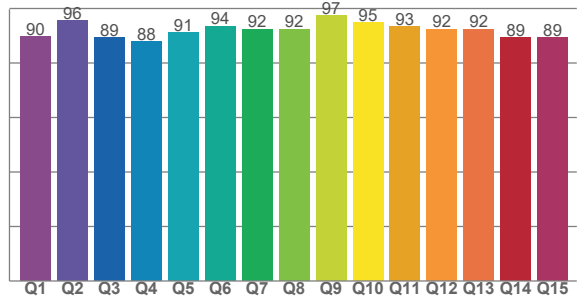

CRI R values, only R1-R8 are used to calculate final CRI value

R1	R2	R3	R4	R5	R6	R7	R8	R9	R10	R11	R12	R13	R14	R15
95.7	98.8	98.3	94.2	95.3	96.3	91.8	84.7	68.0	96.1	95.1	81.8	97.0	99.3	92.3

TM30 C values, 16 binned values out of total of 99 C values

C1	C2	C3	C4	C5	C6	C7	C8	C9	C10	C11	C12	C13	C14	C15	C16
91.4	93.2	92.1	93.4	94.8	96.5	92.4	96.8	92.0	88.1	88.2	90.0	91.7	88.3	92.2	85.6

CQS Q values

Q1	Q2	Q3	Q4	Q5	Q6	Q7	Q8	Q9	Q10	Q11	Q12	Q13	Q14	Q15
89.7	95.6	89.2	87.7	91.0	93.5	92.4	92.4	97.3	94.8	93.3	92.5	92.4	89.3	89.4

Color parameters

Color temperature	Color rendering index	Red component	Color fidelity	Color gamut	Color quality scale	Color coordinate cie 1931	Color coordinate cie 1931	Color coordinate	Color coordinate	Color deviation from black body
CCT	CRI	CRI R9	TM30 Rf	TM30 Rg	CQS	x	y	u	v	Δuv
2944 K	94.4	68.0	91.6	99.1	91.5	0.438	0.399	0.253	0.346	-0.0023

Note: specifications are representative of the diode type and not a particular tape light article.

3000K

Rf 91.6
Fidelity index Rf

Rg 99.1
Gamut index Rg

Hue Bin	R _f	Shifts (%)	
		Chroma	Hue
1	91	-4%	1%
2	93	-2%	2%
3	92	-1%	4%
4	93	-3%	0%
5	95	-1%	1%
6	96	1%	0%
7	92	-4%	1%
8	97	-1%	1%
9	92	-1%	5%
10	88	0%	8%
11	88	3%	8%
12	90	6%	0%
13	92	2%	-6%
14	88	4%	-9%
15	92	-3%	-3%
16	86	-2%	-11%

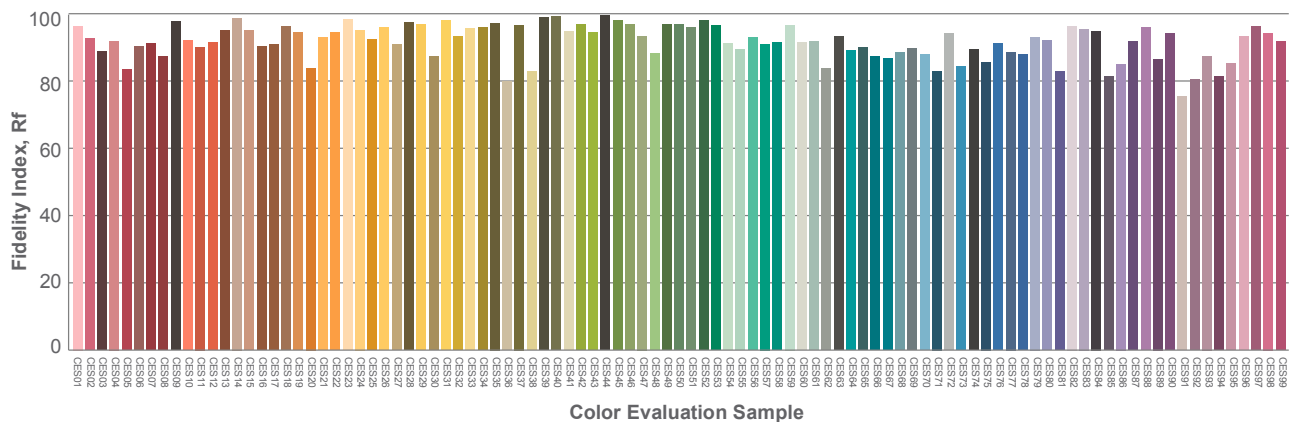
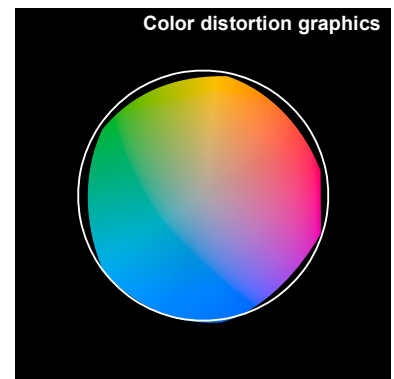
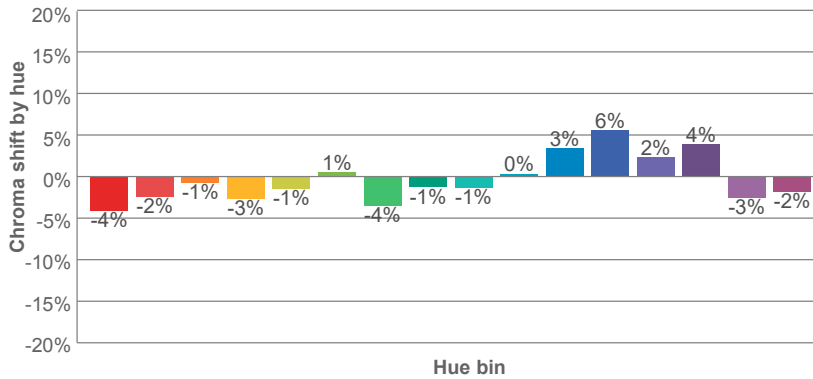
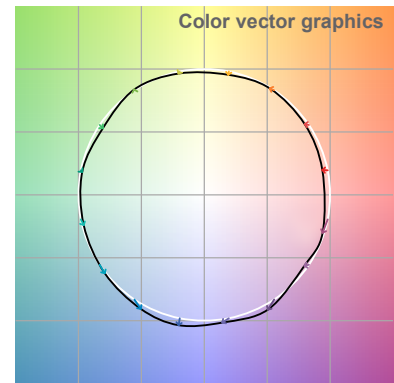
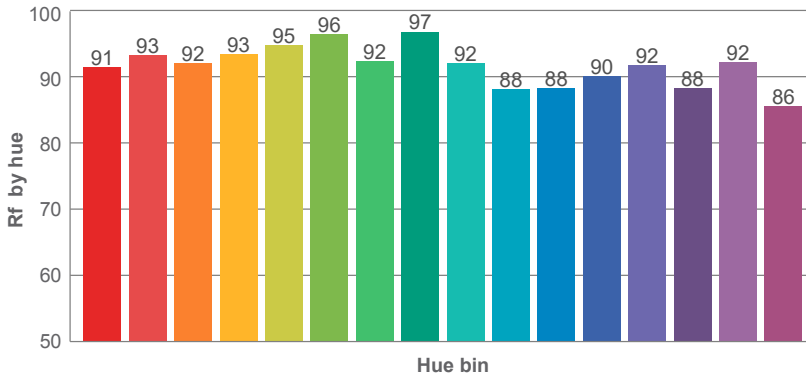
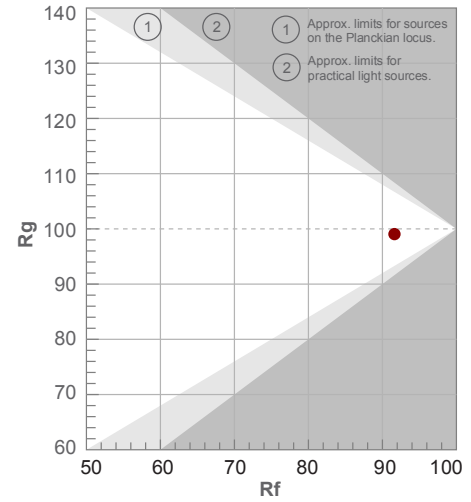

Note: specifications are representative of the diode type and not a particular tape light article.

3000K

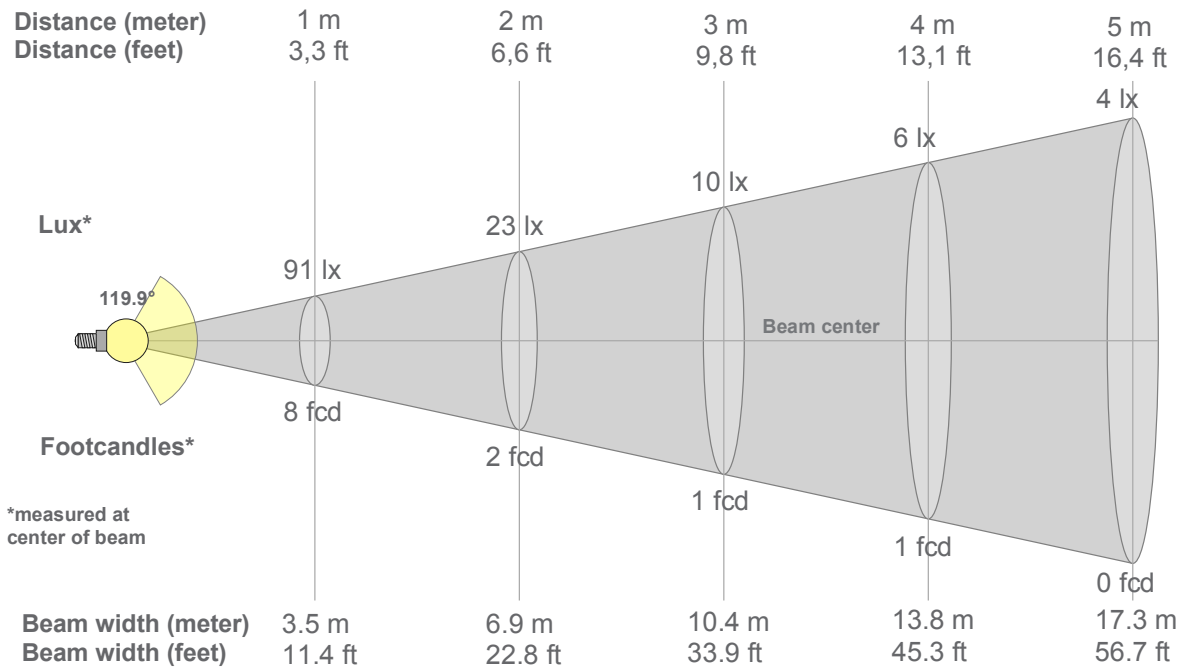

Beam intensities from 1-20m

1m	2m	3m	4m	5m	6m	7m	8m	9m	10m	11m	12m	13m	14m	15m	16m	17m	18m	19m	20m
3.3ft	6.6ft	9.8ft	13.1ft	16.4ft	19.7ft	23ft	26.2ft	29.5ft	32.8ft	36.1ft	39.4ft	42.7ft	45.9ft	49.2ft	52.5ft	55.8ft	59.1ft	62.3ft	65.6ft
91lx	23lx	10lx	6lx	4lx	3lx	2lx	1lx	1lx	1lx	1lx	1lx	1lx	0lx	0lx	0lx	0lx	0lx	0lx	0lx
8.4fcd	2.1fcd	0.9fcd	0.5fcd	0.3fcd	0.2fcd	0.2fcd	0.1fcd	0.1fcd	0.1fcd	0.1fcd	0.1fcd	0fcd	0fcd	0fcd	0fcd	0fcd	0fcd	0fcd	0fcd

Intensities in 0° c-plane

0°	5°	10°	15°	20°	25°	30°	35°	40°	45°	50°	55°	60°	65°	70°	75°	80°	85°	90°	95°
90.8	90.7	89.8	88.2	86.1	83.3	80.0	75.8	71.1	65.7	59.5	52.6	45.1	37.0	28.3	19.4	11.0	4.0	0.2	0.1
100%	100%	99%	97%	95%	92%	88%	84%	78%	72%	66%	58%	50%	41%	31%	21%	12%	4%	0%	0%

Intensities in 90° c-plane

0°	5°	10°	15°	20°	25°	30°	35°	40°	45°	50°	55°	60°	65°	70°	75°	80°	85°	90°	95°
90.8	90.5	89.6	88.0	85.9	83.2	79.9	75.8	71.2	65.8	59.8	52.9	45.3	37.2	28.3	19.4	10.9	3.8	0.1	0.0
100%	100%	99%	97%	95%	92%	88%	84%	78%	72%	66%	58%	50%	41%	31%	21%	12%	4%	0%	0%

Intensities in 180° c-plane

0°	5°	10°	15°	20°	25°	30°	35°	40°	45°	50°	55°	60°	65°	70°	75°	80°	85°	90°	95°
90.8	90.7	89.9	88.4	86.2	83.5	80.2	76.1	71.3	65.8	59.6	52.7	45.1	36.7	27.9	18.9	10.5	3.7	0.3	0.1
100%	100%	99%	97%	95%	92%	88%	84%	79%	72%	66%	58%	50%	40%	31%	21%	12%	4%	0%	0%

Intensities in 270° c-plane

0°	5°	10°	15°	20°	25°	30°	35°	40°	45°	50°	55°	60°	65°	70°	75°	80°	85°	90°	95°
90.8	90.6	89.7	88.2	86.1	83.4	80.0	76.0	71.3	65.9	59.8	53.0	45.3	37.1	28.3	19.3	10.8	3.7	0.1	0.0
100%	100%	99%	97%	95%	92%	88%	84%	79%	73%	66%	58%	50%	41%	31%	21%	12%	4%	0%	0%

Beam angle 50%	Field angle 10%	Cutoff angle 2,5%	Intensity ratio in 120° cone	Intensity ratio in 90° cone
119.9°	162.1°	172.9°	77.8%	51.8%

Note: specifications are representative of the diode type and not a particular tape light article.

4000K

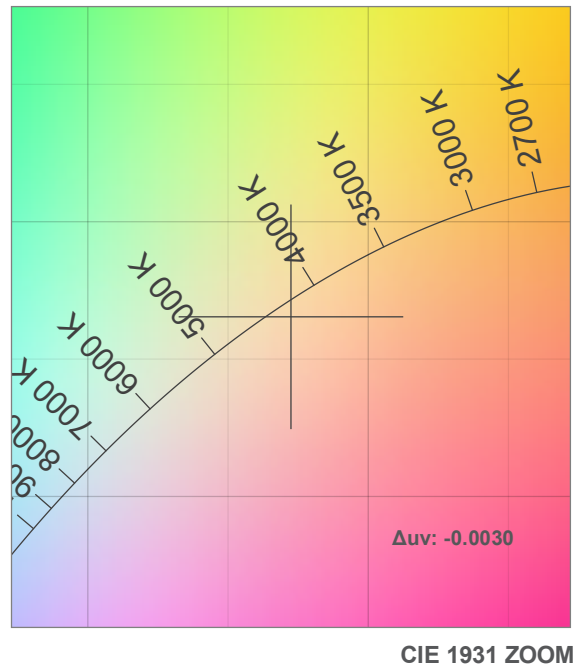
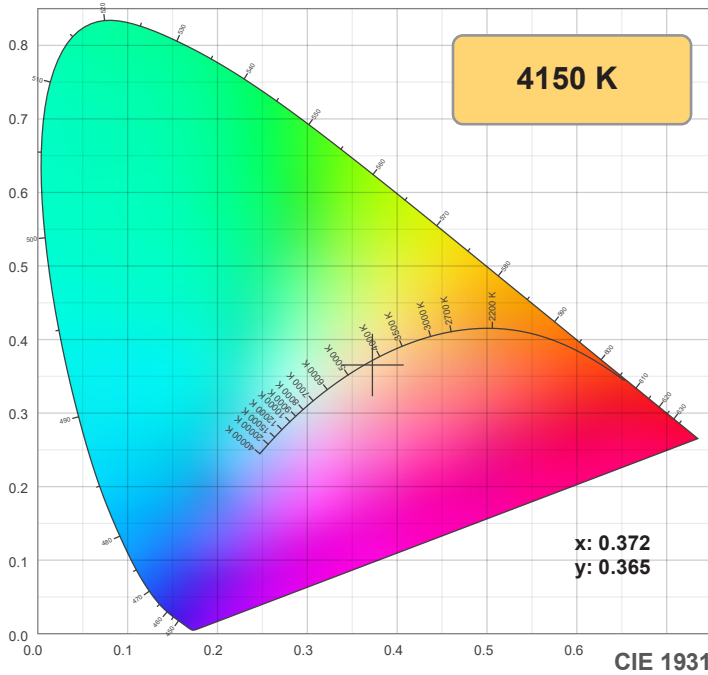

TM-30: 90.5

CRI: 96.1 (R1-R8)

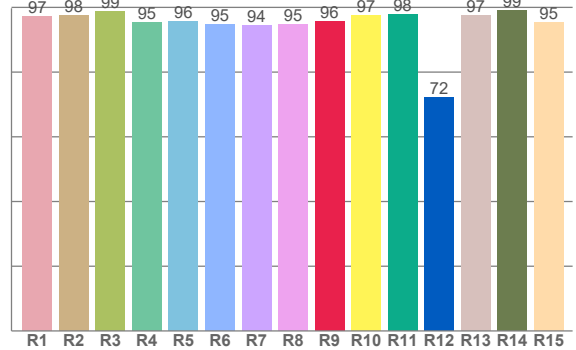
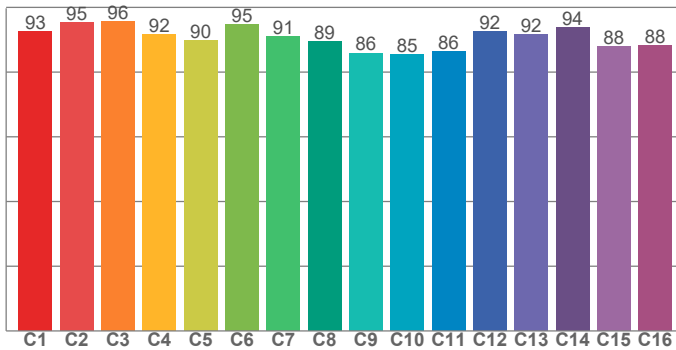

CRI R values, only R1-R8 are used to calculate final CRI value

R1	R2	R3	R4	R5	R6	R7	R8	R9	R10	R11	R12	R13	R14	R15
97.3	97.5	98.8	95.5	95.7	94.7	94.4	94.8	95.6	97.5	97.7	72.1	97.5	99.1	95.3

TM30 C values, 16 binned values out of total of 99 C values

C1	C2	C3	C4	C5	C6	C7	C8	C9	C10	C11	C12	C13	C14	C15	C16
92.5	95.2	95.8	91.5	89.9	94.8	91.0	89.4	85.9	85.3	86.3	92.5	91.5	93.9	88.0	88.3

CQS Q values

Q1	Q2	Q3	Q4	Q5	Q6	Q7	Q8	Q9	Q10	Q11	Q12	Q13	Q14	Q15
90.1	97.0	90.3	87.3	89.8	92.7	98.3	97.8	99.2	99.0	97.7	97.9	97.9	96.6	94.5

CQS: 93.8

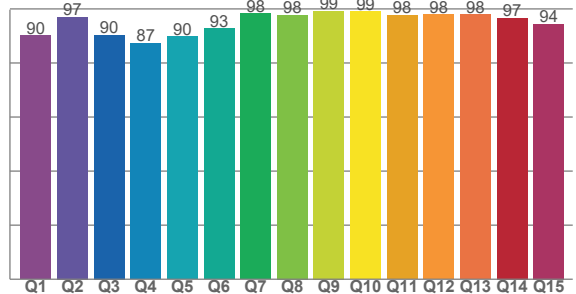

Color parameters

Color temperature	Color rendering index	Red component	Color fidelity	Color gamut	Color quality scale	Color coordinate cie 1931	Color coordinate cie 1931	Color coordinate	Color coordinate	Color deviation from black body
CCT	CRI	CRI R9	TM30 Rf	TM30 Rg	CQS	x	y	u	v	Δuv
4150 K	96.1	95.6	90.5	98.4	93.8	0.372	0.365	0.224	0.330	-0.0030

Note: specifications are representative of the diode type and not a particular tape light article.

4000K

Rf 90.5
Fidelity index Rf

Rg 98.4
Gamut index Rg

Hue Bin	R _f	Shifts (%)	
		Chroma	Hue
1	93	-1%	2%
2	95	0%	0%
3	96	0%	0%
4	92	-4%	-3%
5	90	-7%	-2%
6	95	-3%	0%
7	91	-5%	4%
8	89	-2%	6%
9	86	0%	11%
10	85	1%	9%
11	86	6%	8%
12	92	4%	0%
13	92	3%	-4%
14	94	-1%	-1%
15	88	1%	-5%
16	88	0%	-5%

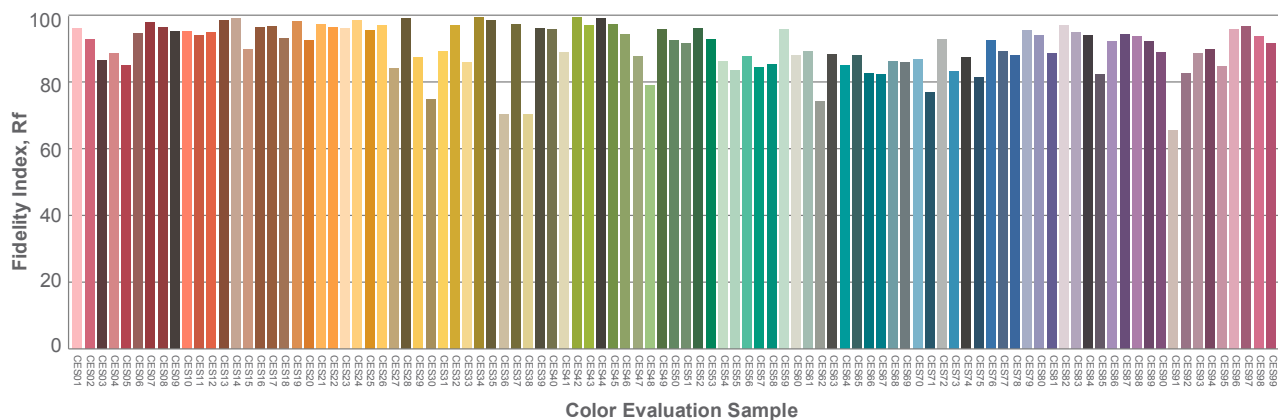
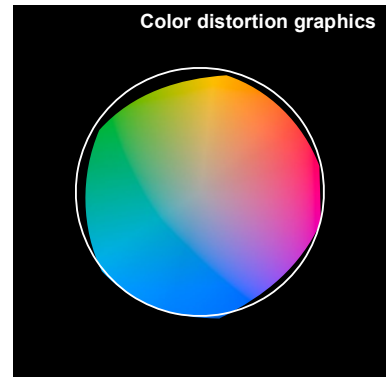
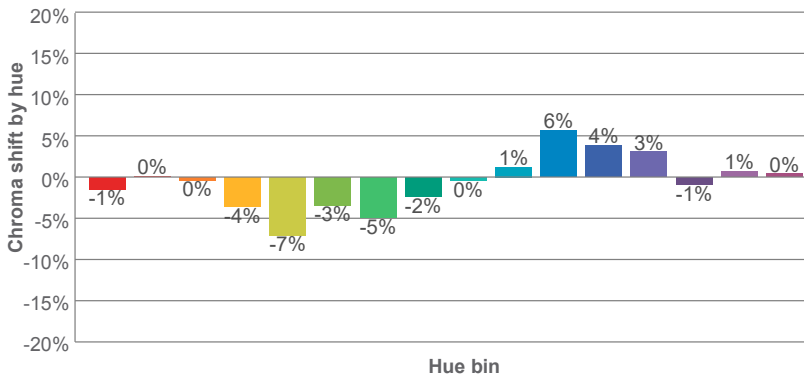
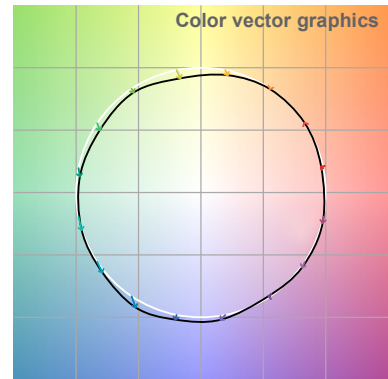
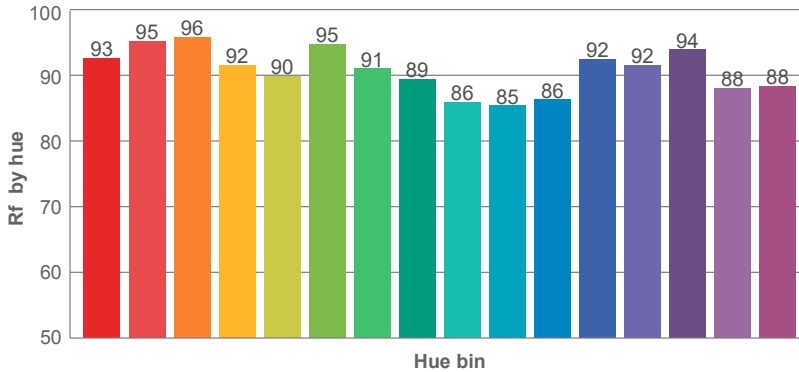
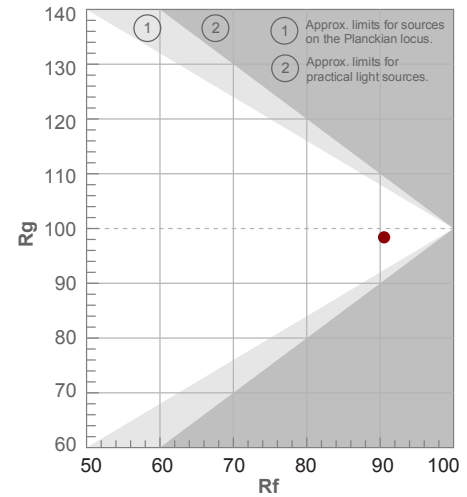

Note: specifications are representative of the diode type and not a particular tape light article.

4000K

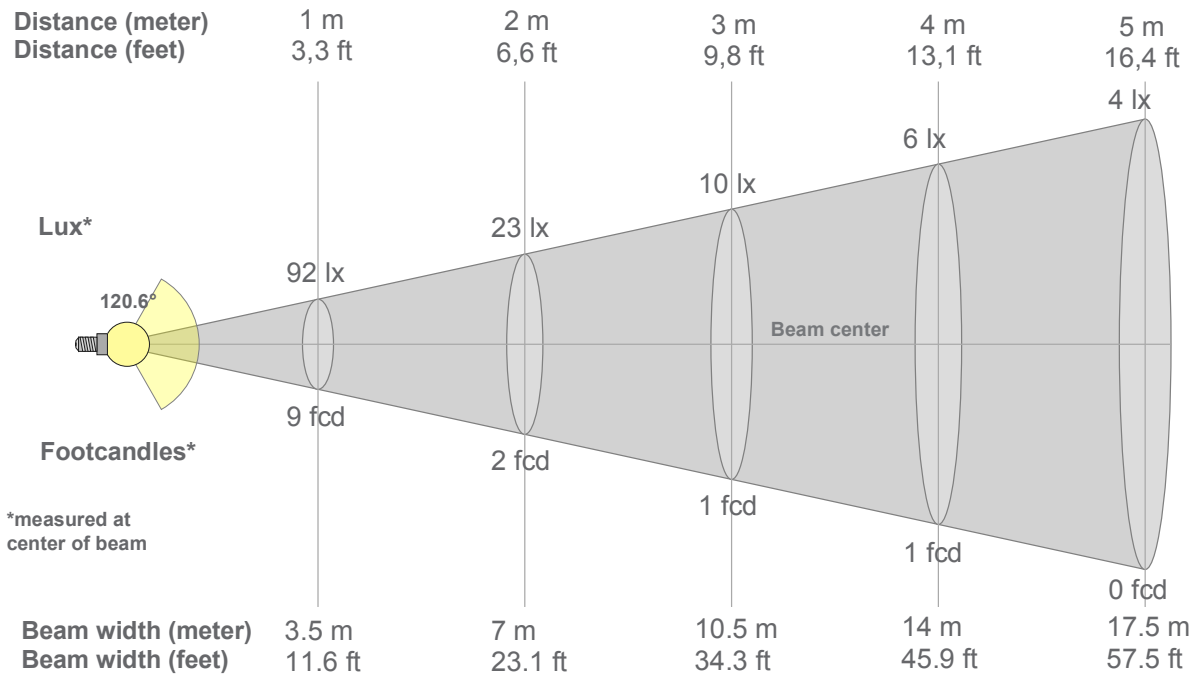

Beam intensities from 1-20m

1m	2m	3m	4m	5m	6m	7m	8m	9m	10m	11m	12m	13m	14m	15m	16m	17m	18m	19m	20m
3.3ft	6.6ft	9.8ft	13.1ft	16.4ft	19.7ft	23ft	26.2ft	29.5ft	32.8ft	36.1ft	39.4ft	42.7ft	45.9ft	49.2ft	52.5ft	55.8ft	59.1ft	62.3ft	65.6ft
92lx	23lx	10lx	6lx	4lx	3lx	2lx	1lx	1lx	1lx	1lx	1lx	1lx	0lx	0lx	0lx	0lx	0lx	0lx	0lx
8.6fcd	2.1fcd	1fcd	0.5fcd	0.3fcd	0.2fcd	0.2fcd	0.1fcd	0.1fcd	0.1fcd	0.1fcd	0.1fcd	0.1fcd	0fcd	0fcd	0fcd	0fcd	0fcd	0fcd	0fcd

Intensities in 0° c-plane

0°	5°	10°	15°	20°	25°	30°	35°	40°	45°	50°	55°	60°	65°	70°	75°	80°	85°	90°	95°
92.1	91.8	90.9	89.4	87.3	84.6	81.2	77.2	72.4	67.0	60.8	53.9	46.3	37.9	29.0	19.9	11.2	4.1	0.5	0.1
100%	100%	99%	97%	95%	92%	88%	84%	79%	73%	66%	59%	50%	41%	31%	22%	12%	4%	1%	0%

Intensities in 90° c-plane

0°	5°	10°	15°	20°	25°	30°	35°	40°	45°	50°	55°	60°	65°	70°	75°	80°	85°	90°	95°
92.1	91.8	90.9	89.4	87.4	84.7	81.4	77.4	72.7	67.3	61.1	54.2	46.5	38.2	29.2	20.0	11.2	4.0	0.4	0.0
100%	100%	99%	97%	95%	92%	88%	84%	79%	73%	66%	59%	51%	41%	32%	22%	12%	4%	0%	0%

Intensities in 180° c-plane

0°	5°	10°	15°	20°	25°	30°	35°	40°	45°	50°	55°	60°	65°	70°	75°	80°	85°	90°	95°
92.1	91.9	91.0	89.6	87.5	84.8	81.5	77.5	72.8	67.3	61.0	54.0	46.2	37.8	28.8	19.6	10.8	3.9	0.3	0.0
100%	100%	99%	97%	95%	92%	89%	84%	79%	73%	66%	59%	50%	41%	31%	21%	12%	4%	0%	0%

Intensities in 270° c-plane

0°	5°	10°	15°	20°	25°	30°	35°	40°	45°	50°	55°	60°	65°	70°	75°	80°	85°	90°	95°
92.1	91.8	90.9	89.5	87.4	84.7	81.4	77.4	72.7	67.3	61.1	54.3	46.5	38.3	29.3	20.1	11.4	4.1	0.4	0.1
100%	100%	99%	97%	95%	92%	88%	84%	79%	73%	66%	59%	51%	42%	32%	22%	12%	4%	0%	0%

Beam angle 50%	Field angle 10%	Cutoff angle 2,5%	Intensity ratio in 120° cone	Intensity ratio in 90° cone
120.6°	162.4°	173.4°	77.6%	51.6%

Note: specifications are representative of the diode type and not a particular tape light article.

5000K

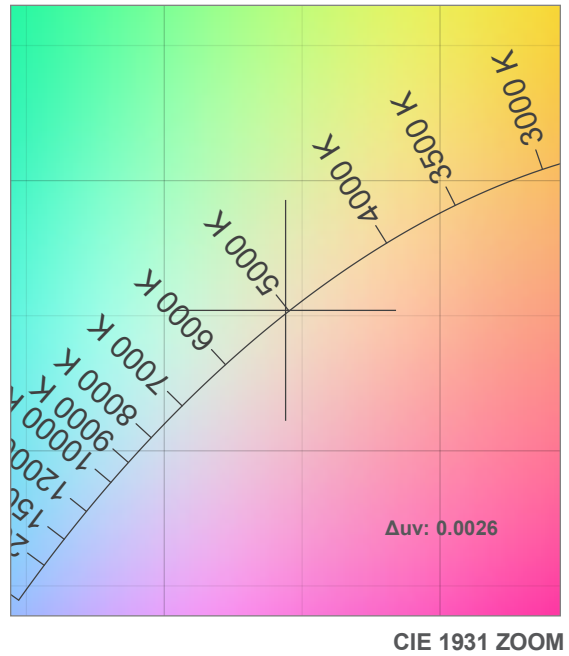
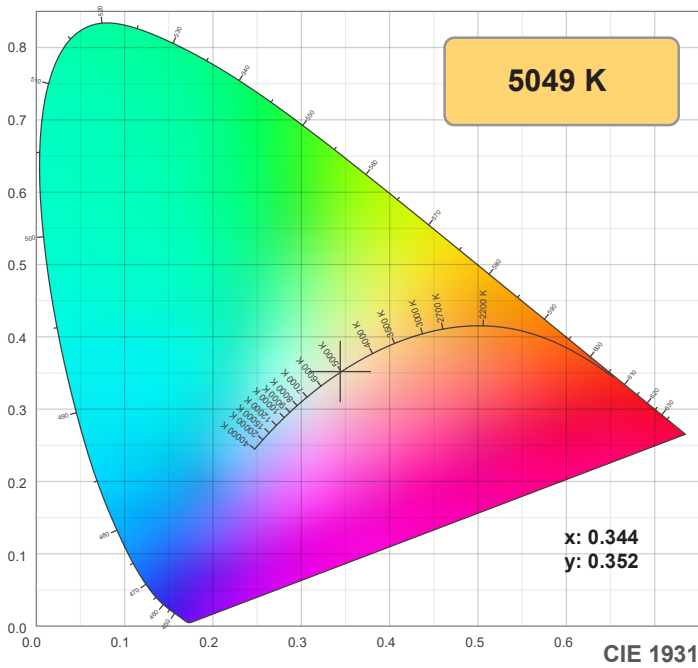

TM-30: 90.4

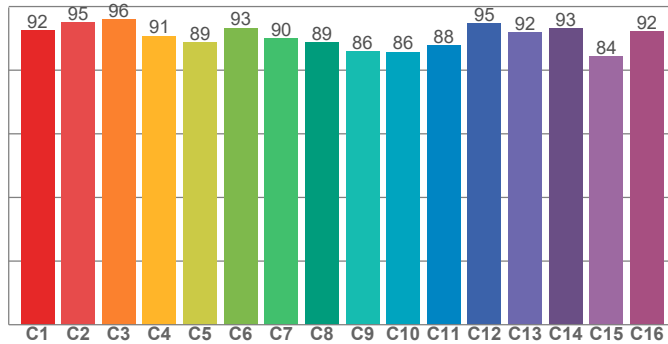

CRI: 95.4 (R1-R8)

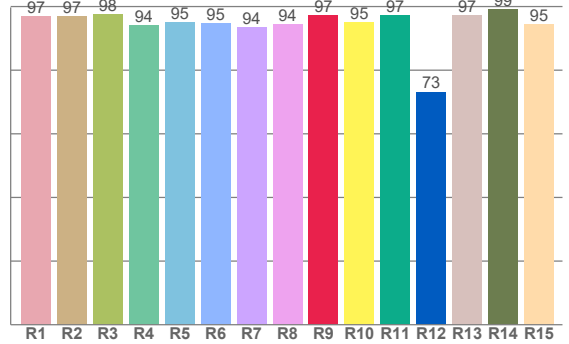

CRI R values, only R1-R8 are used to calculate final CRI value

R1	R2	R3	R4	R5	R6	R7	R8	R9	R10	R11	R12	R13	R14	R15
97.1	97.0	97.6	94.1	95.2	94.7	93.5	94.4	97.3	95.2	97.3	73.2	97.4	99.2	94.6

TM30 C values, 16 binned values out of total of 99 C values

C1	C2	C3	C4	C5	C6	C7	C8	C9	C10	C11	C12	C13	C14	C15	C16
92.4	95.1	95.9	90.8	88.7	93.3	90.0	88.7	86.0	85.8	87.8	94.7	91.8	93.2	84.3	92.3

CQS Q values

Q1	Q2	Q3	Q4	Q5	Q6	Q7	Q8	Q9	Q10	Q11	Q12	Q13	Q14	Q15
89.7	95.9	92.0	88.5	90.0	92.1	97.8	98.0	98.9	99.3	98.6	98.0	97.5	97.2	94.6

CQS: 94.0

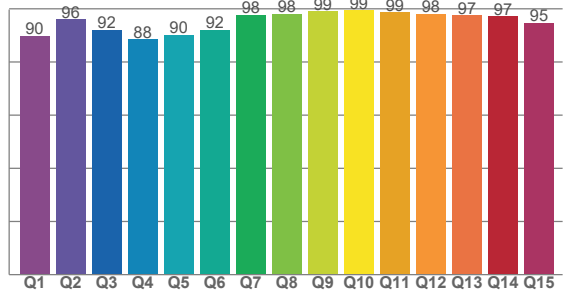

Color parameters

Color temperature	Color rendering index	Red component	Color fidelity	Color gamut	Color quality scale	Color coordinate cie 1931	Color coordinate cie 1931	Color coordinate	Color coordinate	Color deviation from black body
CCT	CRI	CRI R9	TM30 Rf	TM30 Rg	CQS	x	y	u	v	Δuv
5049 K	95.4	97.3	90.4	97.9	94.0	0.344	0.352	0.211	0.323	0.0026

Note: specifications are representative of the diode type and not a particular tape light article.

5000K

Rf 90.4
Fidelity index Rf

Rg 97.9
Gamut index Rg

Hue Bin	R _f	Shifts (%)	
		Chroma	Hue
1	92	-1%	2%
2	95	0%	0%
3	96	0%	-1%
4	91	-4%	-4%
5	89	-8%	-3%
6	93	-5%	0%
7	90	-6%	4%
8	89	-3%	7%
9	86	-1%	11%
10	86	2%	9%
11	88	5%	6%
12	95	2%	-3%
13	92	2%	-4%
14	93	-1%	-3%
15	84	5%	-9%
16	92	-1%	0%

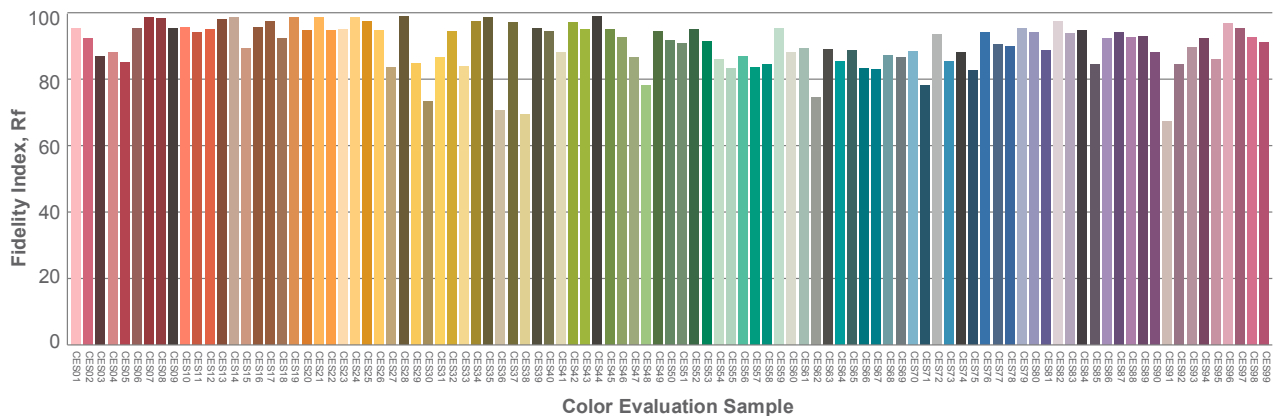
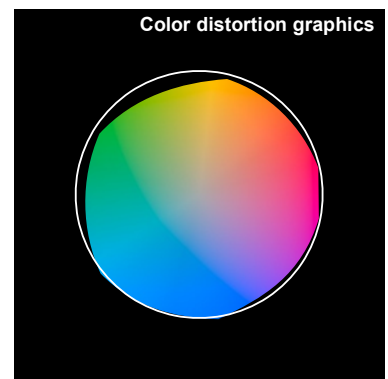
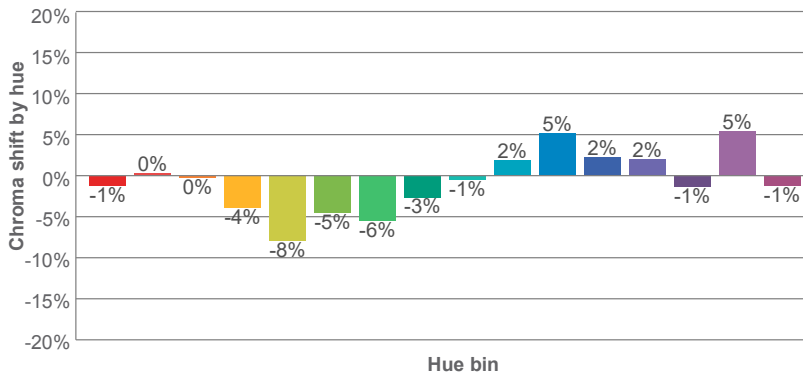
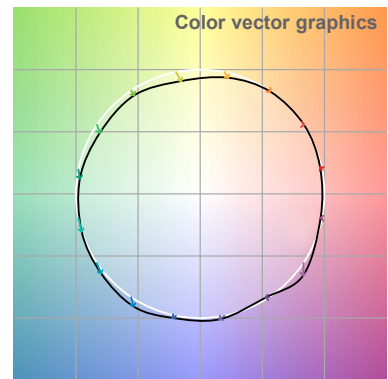
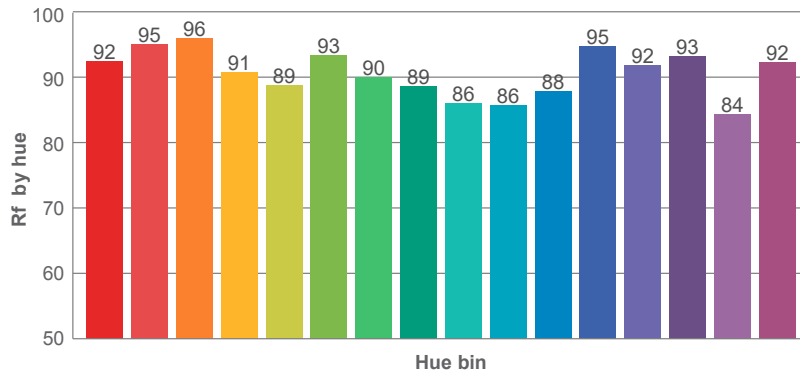
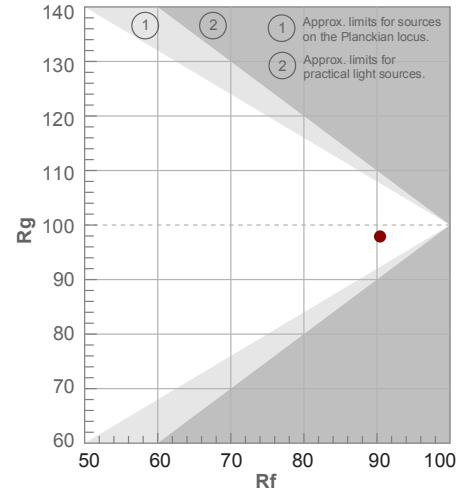

Note: specifications are representative of the diode type and not a particular tape light article.

5000K

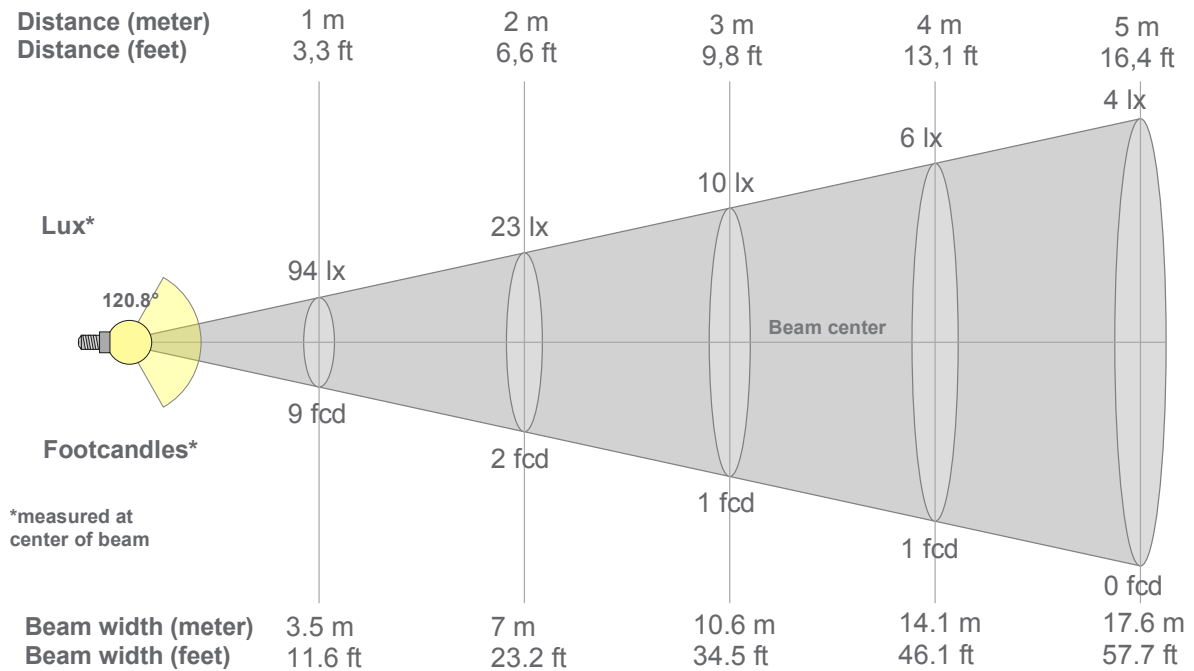

Beam intensities from 1-20m

1m	2m	3m	4m	5m	6m	7m	8m	9m	10m	11m	12m	13m	14m	15m	16m	17m	18m	19m	20m
3.3ft	6.6ft	9.8ft	13.1ft	16.4ft	19.7ft	23ft	26.2ft	29.5ft	32.8ft	36.1ft	39.4ft	42.7ft	45.9ft	49.2ft	52.5ft	55.8ft	59.1ft	62.3ft	65.6ft
94lx	23lx	10lx	6lx	4lx	3lx	2lx	1lx	1lx	1lx	1lx	1lx	1lx	0lx	0lx	0lx	0lx	0lx	0lx	0lx
8.7fcd	2.2fcd	1fcd	0.5fcd	0.3fcd	0.2fcd	0.2fcd	0.1fcd	0.1fcd	0.1fcd	0.1fcd	0.1fcd	0.1fcd	0fcd	0fcd	0fcd	0fcd	0fcd	0fcd	0fcd

Intensities in 0° c-plane

0°	5°	10°	15°	20°	25°	30°	35°	40°	45°	50°	55°	60°	65°	70°	75°	80°	85°	90°	95°
93.5	93.2	92.3	90.8	88.7	86.0	82.6	78.6	73.9	68.3	62.0	54.9	47.1	38.6	29.5	20.2	11.2	4.0	0.2	0.1
100%	100%	99%	97%	95%	92%	88%	84%	79%	73%	66%	59%	50%	41%	32%	22%	12%	4%	0%	0%

Intensities in 90° c-plane

0°	5°	10°	15°	20°	25°	30°	35°	40°	45°	50°	55°	60°	65°	70°	75°	80°	85°	90°	95°
93.5	93.5	92.6	91.1	89.0	86.2	82.8	78.8	74.0	68.5	62.3	55.1	47.4	38.8	29.7	20.3	11.3	4.1	0.2	0.0
100%	100%	99%	97%	95%	92%	89%	84%	79%	73%	67%	59%	51%	41%	32%	22%	12%	4%	0%	0%

Intensities in 180° c-plane

0°	5°	10°	15°	20°	25°	30°	35°	40°	45°	50°	55°	60°	65°	70°	75°	80°	85°	90°	95°
93.5	93.2	92.4	91.0	88.9	86.2	82.9	78.8	74.0	68.5	62.2	55.0	47.1	38.5	29.3	19.9	11.0	3.8	0.5	0.0
100%	100%	99%	97%	95%	92%	89%	84%	79%	73%	66%	59%	50%	41%	31%	21%	12%	4%	0%	0%

Intensities in 270° c-plane

0°	5°	10°	15°	20°	25°	30°	35°	40°	45°	50°	55°	60°	65°	70°	75°	80°	85°	90°	95°
93.5	93.6	92.8	91.3	89.2	86.6	83.2	79.1	74.3	68.7	62.4	55.3	47.4	38.7	29.4	20.0	11.0	3.6	0.2	0.0
100%	100%	99%	98%	95%	93%	89%	85%	79%	74%	67%	59%	51%	41%	31%	21%	12%	4%	0%	0%

Beam angle 50%	Field angle 10%	Cutoff angle 2,5%	Intensity ratio in 120° cone	Intensity ratio in 90° cone
120.8°	162.4°	173.1°	77.6%	51.6%

Note: specifications are representative of the diode type and not a particular tape light article.

6500K

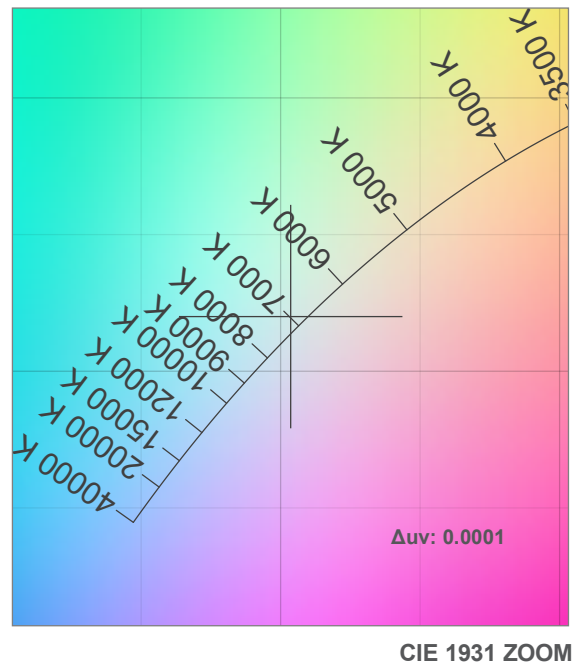
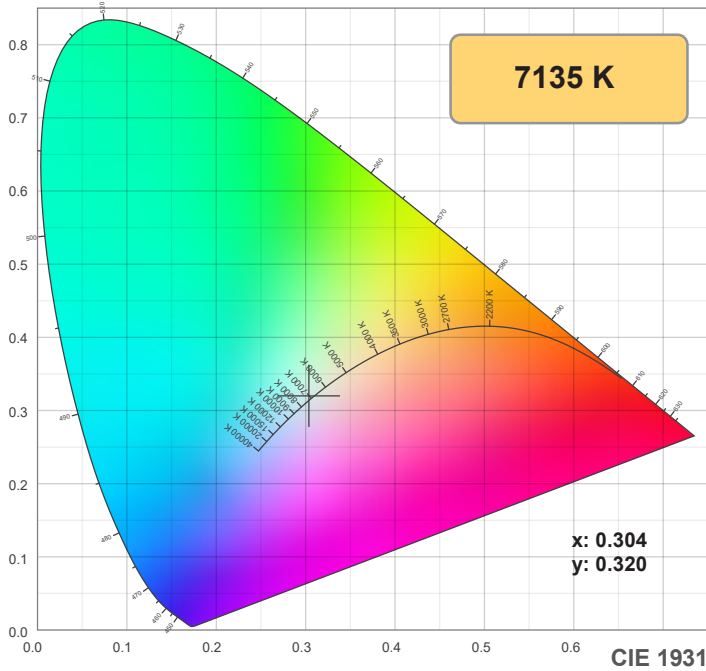

TM-30: 84.7

CRI: 90.2 (R1-R8)

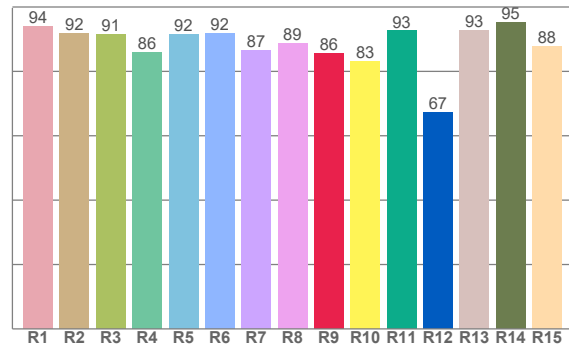
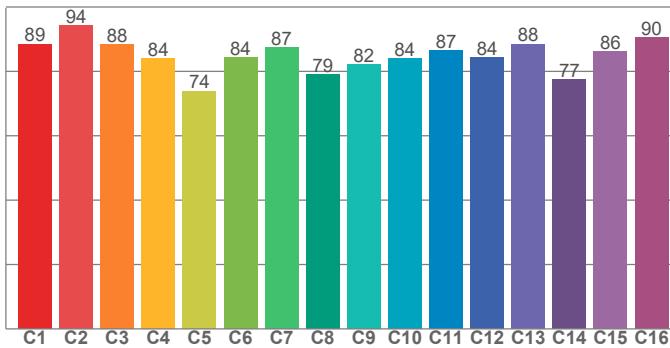

CRI R values, only R1-R8 are used to calculate final CRI value

R1	R2	R3	R4	R5	R6	R7	R8	R9	R10	R11	R12	R13	R14	R15
94.0	91.8	91.5	85.9	91.6	92.0	86.5	88.7	85.6	83.2	92.6	67.3	92.6	95.3	87.9

TM30 C values, 16 binned values out of total of 99 C values

C1	C2	C3	C4	C5	C6	C7	C8	C9	C10	C11	C12	C13	C14	C15	C16
88.5	94.3	88.4	84.0	73.9	84.4	87.3	79.1	82.2	83.9	86.6	84.3	88.5	77.4	86.2	90.5

CQS Q values

Q1	Q2	Q3	Q4	Q5	Q6	Q7	Q8	Q9	Q10	Q11	Q12	Q13	Q14	Q15
81.9	87.4	97.8	90.7	87.2	86.5	92.1	92.5	90.3	89.2	94.1	95.5	98.2	96.3	91.0

CQS: 90.3

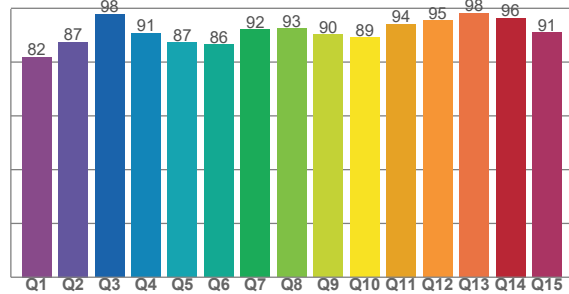

Color parameters

Color temperature	Color rendering index	Red component	Color fidelity	Color gamut	Color quality scale	Color coordinate cie 1931	Color coordinate cie 1931	Color coordinate	Color coordinate	Color deviation from black body
CCT	CRI	CRI R9	TM30 Rf	TM30 Rg	CQS	x	y	u	v	Δuv
7135 K	90.2	85.6	84.7	94.7	90.3	0.304	0.320	0.195	0.308	0.0001

Note: specifications are representative of the diode type and not a particular tape light article.

6500K

Rf 84.7
Fidelity index Rf

Rg 94.7
Gamut index Rg

Hue Bin	R _r	Shifts (%)	
		Chroma	Hue
1	89	0%	4%
2	94	2%	0%
3	88	0%	-8%
4	84	-4%	-9%
5	74	-16%	-8%
6	84	-11%	-1%
7	87	-8%	4%
8	79	-4%	12%
9	82	1%	16%
10	84	5%	11%
11	87	6%	1%
12	84	1%	-10%
13	88	1%	-8%
14	77	7%	-8%
15	86	0%	-5%
16	90	-3%	5%

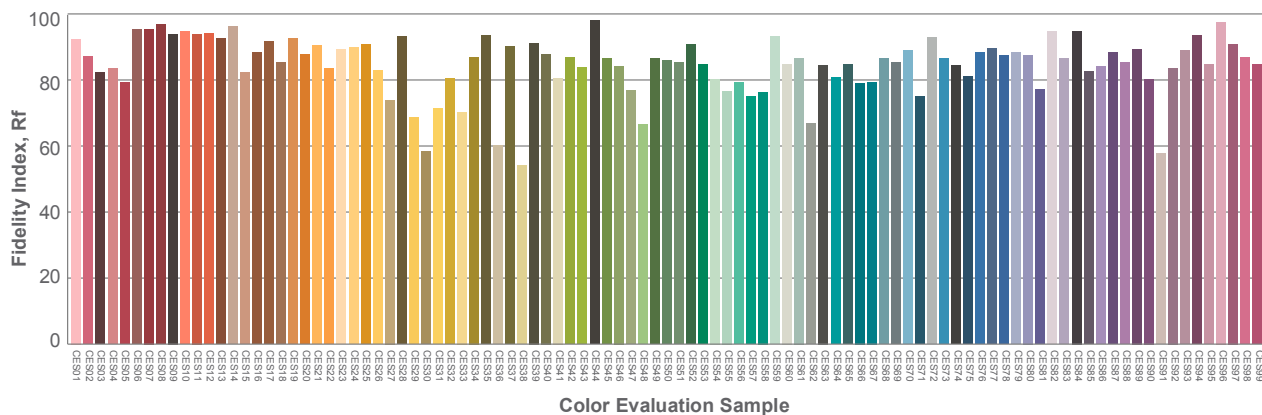
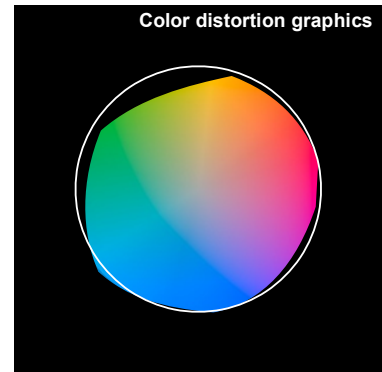
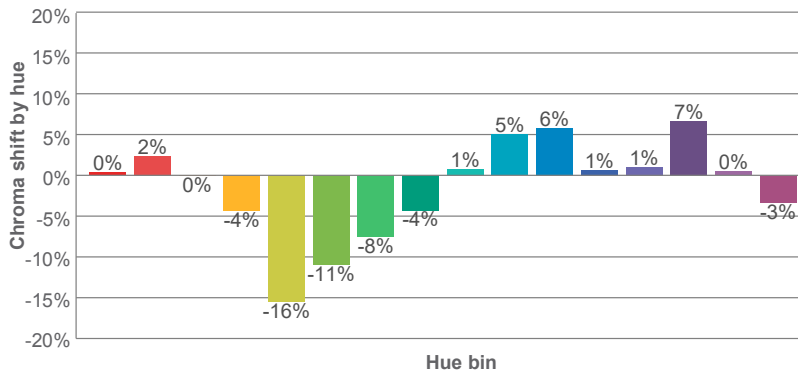
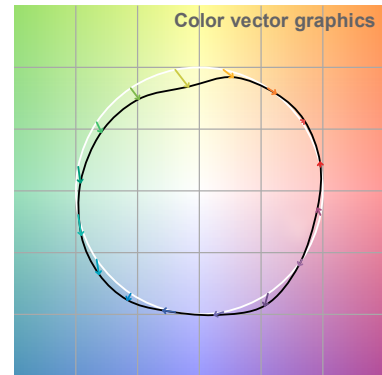
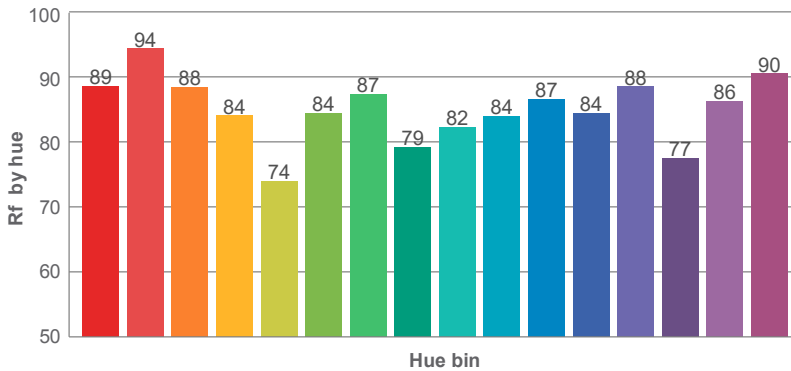
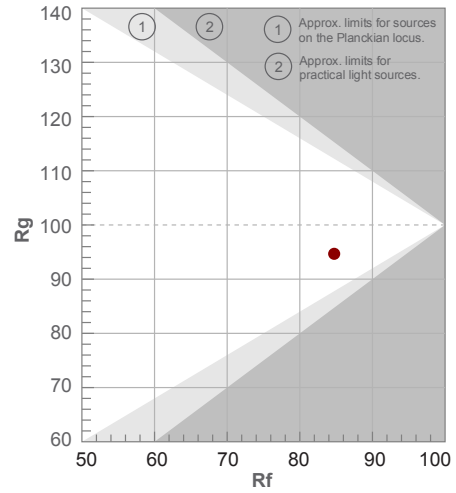

Note: specifications are representative of the diode type and not a particular tape light article.

6500K

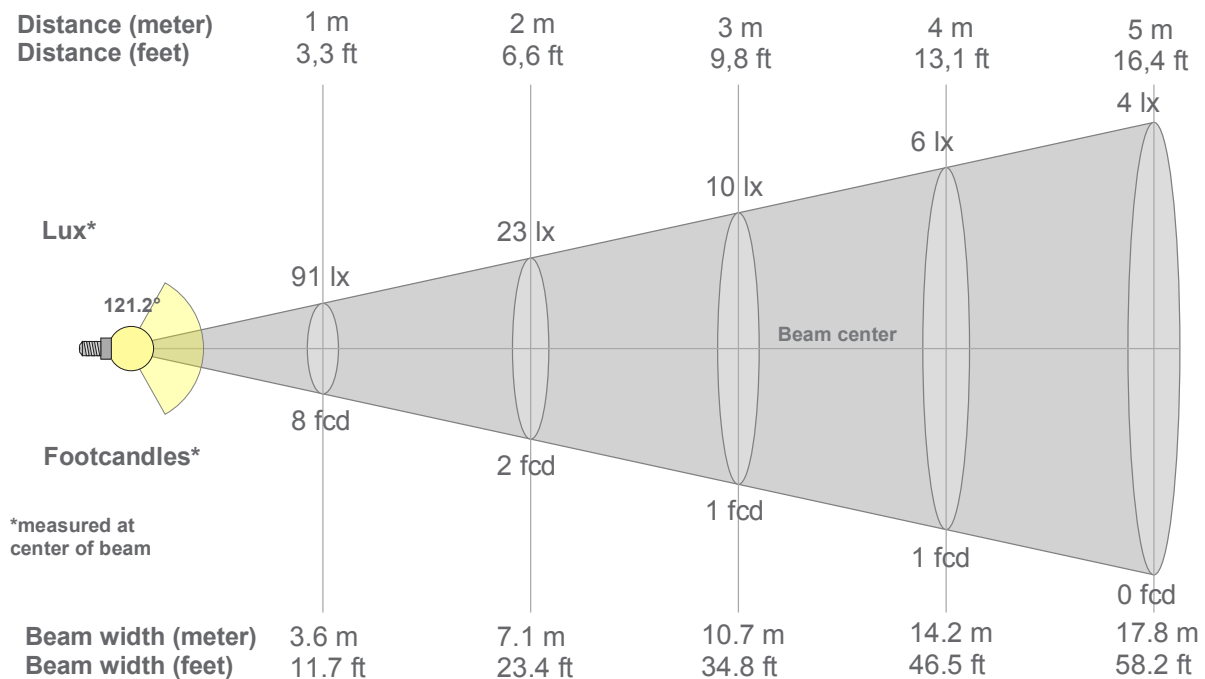

Beam intensities from 1-20m

1m	2m	3m	4m	5m	6m	7m	8m	9m	10m	11m	12m	13m	14m	15m	16m	17m	18m	19m	20m
3.3ft	6.6ft	9.8ft	13.1ft	16.4ft	19.7ft	23ft	26.2ft	29.5ft	32.8ft	36.1ft	39.4ft	42.7ft	45.9ft	49.2ft	52.5ft	55.8ft	59.1ft	62.3ft	65.6ft
91lx	23lx	10lx	6lx	4lx	3lx	2lx	1lx	1lx	1lx	1lx	1lx	1lx	0lx	0lx	0lx	0lx	0lx	0lx	0lx
8.5fcd	2.1fcd	0.9fcd	0.5fcd	0.3fcd	0.2fcd	0.2fcd	0.1fcd	0.1fcd	0.1fcd	0.1fcd	0.1fcd	0.1fcd	0fcd	0fcd	0fcd	0fcd	0fcd	0fcd	0fcd

Intensities in 0° c-plane

0°	5°	10°	15°	20°	25°	30°	35°	40°	45°	50°	55°	60°	65°	70°	75°	80°	85°	90°	95°
91.2	90.9	90.0	88.6	86.6	83.9	80.7	76.8	72.1	66.8	60.8	53.9	46.3	38.0	29.1	20.0	11.2	4.0	0.3	0.0
100%	100%	99%	97%	95%	92%	88%	84%	79%	73%	67%	59%	51%	42%	32%	22%	12%	4%	0%	0%

Intensities in 90° c-plane

0°	5°	10°	15°	20°	25°	30°	35°	40°	45°	50°	55°	60°	65°	70°	75°	80°	85°	90°	95°
91.2	90.9	90.3	88.9	87.1	84.6	81.4	77.6	73.0	67.7	61.5	54.5	46.7	38.1	28.9	19.5	10.7	3.5	0.1	0.0
100%	100%	99%	98%	95%	93%	89%	85%	80%	74%	67%	60%	51%	42%	32%	21%	12%	4%	0%	0%

Intensities in 180° c-plane

0°	5°	10°	15°	20°	25°	30°	35°	40°	45°	50°	55°	60°	65°	70°	75°	80°	85°	90°	95°
91.2	91.0	90.2	88.8	86.8	84.3	81.0	77.1	72.5	67.0	60.9	54.0	46.3	37.9	28.8	19.6	10.7	3.5	0.2	0.0
100%	100%	99%	97%	95%	92%	89%	85%	79%	74%	67%	59%	51%	42%	32%	21%	12%	4%	0%	0%

Intensities in 270° c-plane

0°	5°	10°	15°	20°	25°	30°	35°	40°	45°	50°	55°	60°	65°	70°	75°	80°	85°	90°	95°
91.2	90.7	89.8	88.2	86.1	83.5	80.3	76.4	71.8	66.6	60.7	54.1	46.6	38.5	29.7	20.7	12.0	4.6	0.3	0.0
100%	99%	98%	97%	94%	92%	88%	84%	79%	73%	67%	59%	51%	42%	33%	23%	13%	5%	0%	0%

Beam angle 50%	Field angle 10%	Cutoff angle 2,5%	Intensity ratio in 120° cone	Intensity ratio in 90° cone
121.2°	162.4°	173.1°	77.6%	51.5%