



Wattstopper®

Wireless Dimming 0-10V Room Controller

No: 28388 – 10/24 rev. 10

Quick Start Guide • Guide de démarrage rapide • Guía de inicio rápido

Catalog Number • Numéro de Catalogue • Número de Catálogo: LMRC-611-16M

Country of Origin: Made in China • Pays d'origine: Fabriqué en Chine • País de origen: Hecho en China

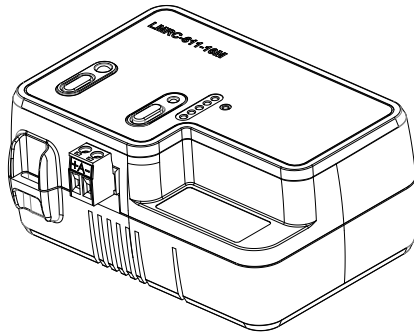

Installation shall be in accordance with all applicable regulations, local and NEC codes. Wire connections shall be rated suitable for the wire size employed.

For Class 2 DLM devices and device wiring: To be connected to a Class 2 power source only. Do not reclassify and install as Class 1, or Power and Lighting Wiring.

IMPORTANT SAFEGUARDS

When using electrical equipment, basic safety precautions should always be followed including the following:

- READ AND FOLLOW ALL SAFETY INSTRUCTIONS.
- Do not use outdoors.
- Do not mount near gas or electric heaters.
- Equipment should be mounted in locations and at heights where it will not readily be subjected to tampering by unauthorized personnel.
- The use of accessory equipment not recommended by the manufacturer may cause an unsafe condition.
- Do not use this equipment for other than intended use.
- Installation should be performed by qualified service personnel.

SAVE THESE INSTRUCTIONS

PRODUCT DESCRIPTION

The LMRC-611-16M is a wireless room controller that is compatible with all Wattstopper IPv6/Bluetooth® low energy technology wireless DLM sensors and switches. Using Push-to-Pair or the DLM Config App, wireless devices can be paired to a room controller for stand-alone room operation.

IMPORTANT INSTALLATION NOTES:

- You must maintain a minimum of 6" between each room controller on the same junction box. This means mounting the LMRC on opposite ends.
- Ceiling mounted LMRCs must be mounted with the label side facing down towards the floor to increase communication performance with other wireless switch and sensor devices. LMRCs mounted on the wall must have the unit label face into the room.

SPECIFICATIONS

Input Voltage	120/277VAC, 50/60Hz
Relay rated for up to:	
Incandescent.....	16A @120VAC
Ballast and E-Ballast.....	16A @120/277VAC
Class 1 & 2 Dimming Output, 0-10V sinks up to 50mA per channel	
Metering capability provides power monitoring within 2% of the true value.	
Environment:	
Operating Temperature	32° to 131°F (0° to 55°C)
Storage Temperature	23° to 176°F (-5° to 80°C)
Relative Humidity	5 to 95% (non condensing)
Connection to DLM Network.....	Wireless
Wireless Radio	Single, Concurrent 802.15.4 and Bluetooth Low Energy, 2.4GHz
Wireless Communication	
IPv6 Mesh range between wire powered devices (LMRC-6xx, LMPL-6xx)	up to 100 ft.
IPv6 Mesh range for battery powered devices.....	up to 60 ft.
Bluetooth low energy range	up to 30 ft.
Wireless Encryption.....	AES-128 bit symmetric key
Compliance/Regulatory	
UL2043 Plenum rated, FCC, RoHS,	
Bluetooth certified	
UL and cUL listed (E101196)	
UL/CUL listed under UL60730. This model is Complementary Listed to "Emergency Lighting Equipment", (UL924) intended for Indoor Dry Locations.	

MOUNTING AND WIRING

The LMRC-611-16M room controller can be mounted external to any junction box with 1/2" knockouts, and can be mounted in a plenum space.

If mounting two controllers on the same junctions box, **you must maintain a minimum of 6" between each room controller.** This means mounting the LMRC on opposite ends.

IMPORTANT:

CEILING MOUNTED LMRCs MUST BE MOUNTED WITH THE LABEL SIDE FACING DOWN TOWARDS THE FLOOR TO INCREASE COMMUNICATION PERFORMANCE WITH OTHER WIRELESS SWITCH AND SENSOR DEVICES.

LMRCs MOUNTED ON THE WALL MUST HAVE THE UNIT LABEL FACE INTO THE ROOM.

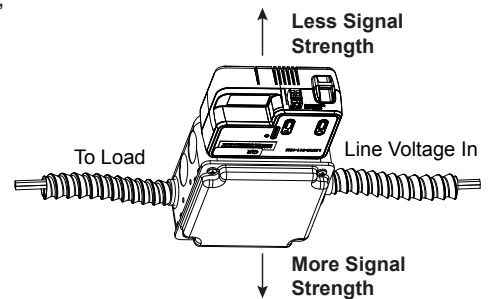

All line voltage wiring is #14 AWG. The relay is rated for up to 16A; total load for LMRC-611-16M not to exceed 16A. On/Off or 0–10V dimming loads can connect to any load relay.

For dimming ballasts, either or both the Class 1 and Class 2 0–10V wires may be connected. For Class 1 Dimming, wiring is 18# AWG.

Class 1 is preferred in new installations when the purple and pink dimming signal wires are included in the fixture power cable. Class 2 is used for new or existing installation when it is easier to run the purple and pink dimming signal wires outside the fixture cable.

Class 1 and Class 2 wiring should be maintained throughout the installation and cannot be swapped—appropriate wiring practices should be used. Class 1 and Class 2 circuitry in the LMRC-611-16M units are galvanically isolated.

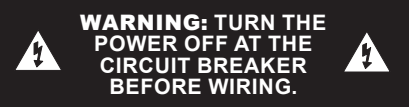

LMRC-611-16M with Class 1 Dimming

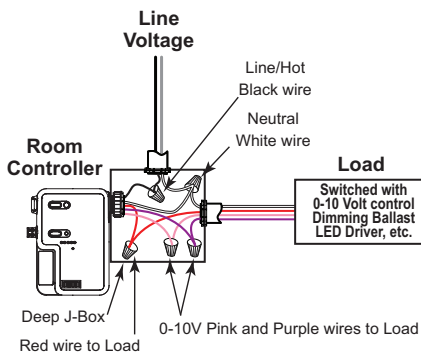

LMRC-611-16M with Class 2 Dimming

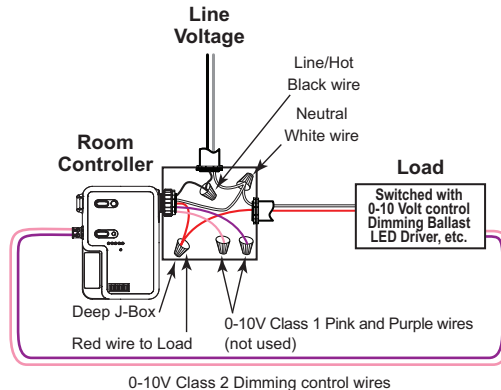

0-10V Class 2 Connections

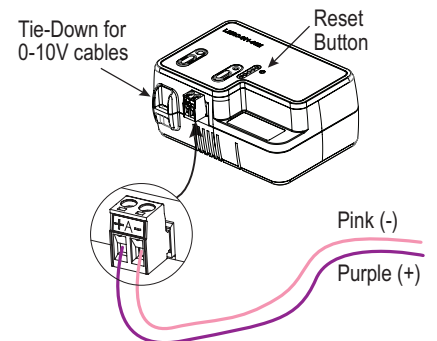

NOTE: Per UL, the 0-10V negative dimming wire color has been changed from gray to pink.

USING THE LMRC-611-16M WITH EMERGENCY LIGHTING

When used with an ELCU

Wattstopper recommends using an ELCU device when the Emergency Light should turn On and Off based on a Normal Power Circuit in the room. In this scenario, the LMRC-611-16M's 0-10VDC dimming circuit is connected to and alters the light level of both normally powered lighting loads and emergency powered lighting loads. The 0-10V signal is generated individually by each ballast or driver when they are powered.

NOTE: Class 1 or class 2 dimming may be used. (Class 2 dimming shown in diagram.)

When Normal Power is available:

When Normal Power is available and the normal load has been turned off by any DLM device (OS, photocell, or dimmer switch, or LMRC override button), the ELCU will turn off the Emergency Load as well.

When Normal Power is unavailable:

When normal power to the room controller fails for any reason, the 0-10VDC dimming circuit in the LMRC-611-16M will revert to an open circuit. Since no device is controlling the 0-10V circuit, any fixture that is fed by emergency power will go full on. Fixtures fed by normal power will be off since there is no power available for their operation.

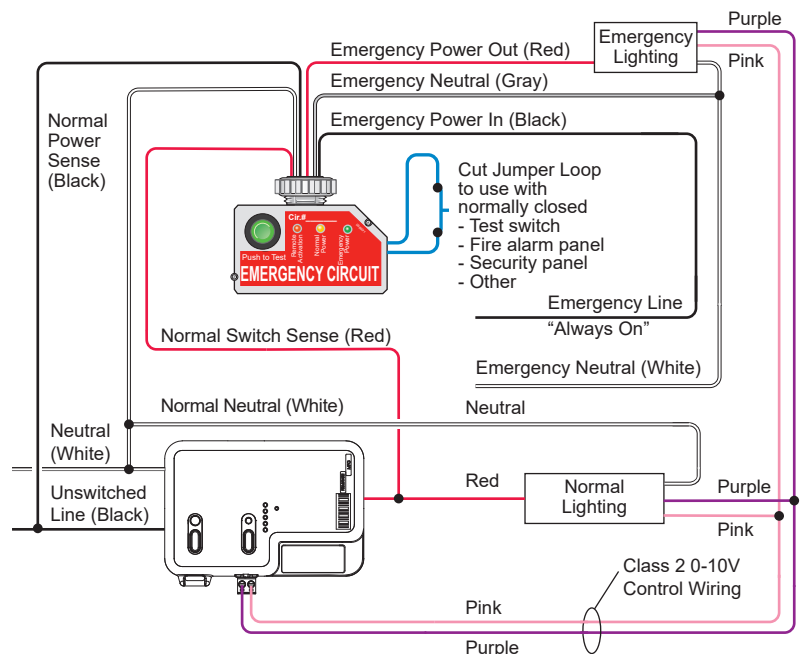

When no ELCU is used:

In this scenario, emergency lighting cannot be turned off by a DLM device, only dimmed to its lowest possible level. The normal lighting load has full control. As in the example with the ELCU, if normal power fails, the emergency load will go full on. If any Emergency Circuits are fed or controlled from a panel, they must be located electrically where fed from a UPS, generator, or other guaranteed source of power during emergency and power outage situations.

NOTE: Class 1 or class 2 dimming may be used. (Class 2 dimming shown in diagram.)

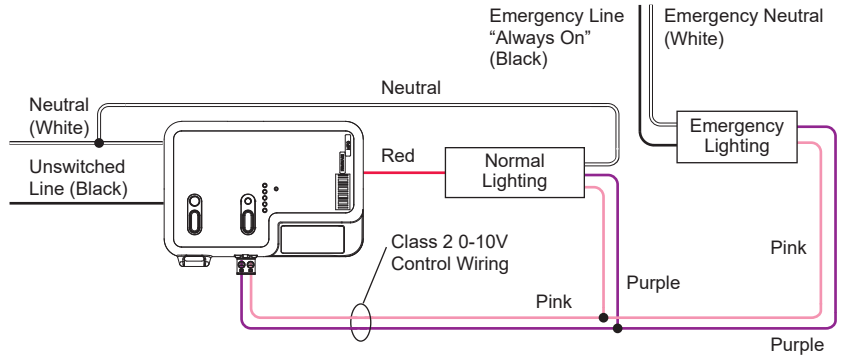

WIRELESS DLM CONNECTION

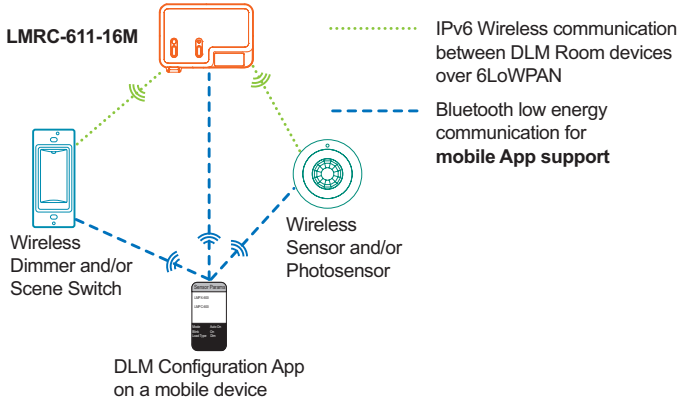

Distance Recommendations for LMRC-611-16M:

- 6" minimum and 100' maximum between any LMRC-6xx, LMPL-6xx load controller
- 30' maximum between this device and a mobile device
- 60' maximum between this device and a battery device

IMPORTANT INSTALLATION INFORMATION

To ensure a successful installation and startup of a wireless system, the following steps must be taken by the installing contractor. **Failure to document all device address and locations may delay completion of startup and result in additional startup charges.**

Key Requirement: Document every Device's MAC Address (at least the last 4 alphanumeric characters). An additional MAC address label is included for the installer to use on a floor plan map. The last four characters are repeated in a larger font, in bold. Keep this document so that the commissioning tech has access at a later date.



Examples of labels

SETTING UP A ROOM NETWORK BY PAIRING DEVICES

Pair wireless devices to a room controller to create an individual room network and enable Plug N' Go operation.

Device pairing can be done by using Push-to-Pair (PtP) mode on the room controller and all other wireless devices, or by using the DLM Config App.

To pair devices in a network, they must all have the same wireless channel and Network ID. By default the channel is 15 and the Network ID is 1. Using Push-to-Pair mode, the Network ID for all devices being paired is migrated to a new number, so that only those devices communicate with each other. The channel number will remain at 15.

SET UP A ROOM NETWORK USING PUSH-TO-PAIR MODE

Push-to-Pair in a room with a single LMRC-611-16M Room Controller

NOTE: Once you enter PtP mode on the room controller, a three minute timer begins. If the Config button on any device in the room is pressed, the timer resets and begins the three minute countdown again. If no Config button is pressed within three minutes, the room controller will exit PtP mode.

1. **Enter PtP mode on the room controller.** Press the Config button three times (within three seconds) until the LED on the room controller flashes green.
2. **Enter PtP mode on a sensor or switch.** On one of the sensors or switches, press the Config button three times. As with the room controller, the LED on the device will flash green.
3. **Pair the devices.** On that same sensor or switch, press the Config button one more time to pair it to the room controller. The load connected to the room controller will toggle once (if the load is OFF, it will turn ON; if ON, it will turn OFF) to indicate that pairing was successful. Also, the sensor or switch's blinking LED will turn to solid green as another indicator of a successful pairing.

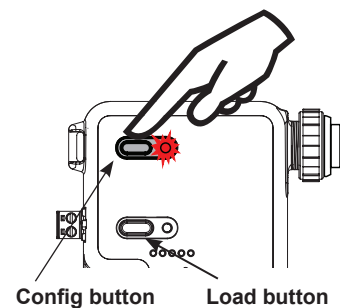

NOTE: Repeat steps 2 and 3 for each sensor and switch in the room, so that all devices are paired together in the same network. For each device, the load will toggle during step 3 and its config LED will turn solid green.

4. **Exit PtP mode.** From any device, press the Config button 3 times. After a few seconds, the LED on each Room controller, switch or sensor currently in PtP mode will flash white and reboot, leaving the default network and migrating to the new network. Then, the LED on the room controller will flash blue and the pairing process finishes. The default Network ID on all devices will change to a new number, based on the last four digits of the Mac address on the room controller, and now those devices will communicate only with each other and not any devices which have not been paired.

NOTE: It is important to exit PtP mode within the three minute time limit mentioned above. If you do not, none of the device pairings will be remembered and you have to start the process over from the beginning.

Push-to-Pair in a room with multiple LMRC-611-16Ms or LMRC-611MCCs

In a room with multiple loads, there may be more than one wireless room controller. They can all be paired to the same room network, allowing the scene switch to set each load to different levels per scene. One of the room controllers will become the primary, determining the Network ID and channel settings for all the devices in the network.

1. **Enter wireless Push-to-Pair (PtP) mode on all room controllers.** Press the Config button three times on each LMRC-611 to put them all in PtP mode. The green LEDs will flash on all room controllers. The **first** room controller placed into PtP will become the **primary**.
2. **Pair the room controllers together.** Press the Config button one more time on each room controller **except** for the primary. This indicates to the rooms controllers that they will be paired with each other.

The primary room controller's LED blink rate will double once the first device is paired to it. This faster blink rate is convenient when multiple room controllers are present on the same network. The LED will turn solid on the other controllers being paired.

NOTE: If there are more than two room controllers, you have the choice of either placing them all in PtP mode and then pairing them, or pairing the first two controllers and then repeating steps 1 and 2 for each additional controller, leaving the primary controller in PtP mode the entire time.

3. **Enter PtP mode on a sensor or switch.** On one of the sensors or switches, press the Config button three times. As with the room controller, the LED on the device will flash green.
4. **Pair the devices.** On that same sensor or switch, press the Config button one more time to pair it to the room controller. The load connected to the room controller will toggle once (if the load is OFF, it will turn ON; if ON, it will turn OFF) to indicate that pairing was successful and its config LED will turn solid green.

NOTE: Repeat steps 3 and 4 for each sensor and switch in the room, so that all devices are paired together in the same network. For each device, the load will toggle and its config LED will turn solid green during step 3.

5. **Exit PtP mode.** From any device, press the Config button 3 times. After a few seconds, the LED on each Room controller, switch or sensor currently in PtP mode will flash white and reboot, leaving the default network and migrating to the new network. Then, the LED on the room controller will flash blue and the pairing process finishes. The default Network ID on all devices will change to a new number, based on the last four digits of the Mac address on the primary room controller, and now those devices will communicate only with each other and not any devices which have not been paired.

NOTE: It is important to exit PtP mode within the three minute time limit mentioned above. If you do not, none of the device pairings will be remembered and you have to start the process over from the beginning.

Pairing a device to an existing network

If you need to add a device to an existing in-room network, follow the procedure below:

1. **Enter wireless Push-to-Pair (PtP) mode on the room controller or any currently paired battery device.** Press the Config button three times (within three seconds). The LED on the room controller and any paired battery devices that are currently awake will flash green.
2. **Enter PtP mode on the new device.** On the new device, press the Config button three times. As with the room controller, the LED on the switch will flash green.
3. **Pair the devices.** On the new device, press the Config button one more time to pair it to the room controller. The load connected to the room controller will toggle once (if the load is OFF, it will turn ON; if ON, it will turn OFF) to indicate that pairing was successful and its config LED will turn solid green.
4. **Exit PtP mode.** From any device, press the Config button 3 times. After a couple of seconds, the LED on the LMDM-601 will flash white and reboot, leaving the default network and migrating to the new network. Then the LED on the room controller will flash blue while it completes the pairing process. The Network ID of the LMRC-611-16M will change to the value used by the previously paired devices and the room controller also returns to that value.

DEVICE PAIRING AND UNIT ADJUSTMENT USING THE DLM CONFIG APP

The DLM Config App is available for both iOS® and Android® devices. Search "DLM Config" on your device to download.

The app provides the ability to pair various devices in a room. Additionally, you can modify load binding and edit various DLM parameters for each device.

For details on the features and operation, download the DLM Config App User Guide from the wattstopper web site at: <https://www.legrand.us/wattstopper/software>



PLUG N' GO

Plug n' Go supports the most energy efficient control strategy. A set of wireless scenes are automatically assigned for load control by switches and sensors, after pairing is complete.

UNIT ADJUSTMENT – PUSH N’ LEARN (PNL)

Load Selection Procedure

In situations in which there is more than one LMRC-611-16M in a room, the configuration button allows access to Push n’ Learn™ (PnL) technology to change the binding relationship between the LMDM-601/LMSW-6xx series switches and loads.

NOTE: PnL cannot be used to change the binding on wireless sensors, although it is possible to enter PnL mode from a sensor.

Step 1 Enter Push n’ Learn

Press and hold the Config button (on any DLM device) for 3 seconds.

The red LED on the LMRC-611-16M begins to blink. The LED on all switches and sensors in the local room network will also blink red. The LEDs will continue to blink until you exit PnL mode.

NOTE: If a switch or sensor is currently “asleep”, it will not blink. To ensure the switch is currently awake before initiating PnL, press its Config button first, or initiate PnL from that switch.

All loads in the room turn OFF immediately after entering PnL, then one load will turn ON. This is Load #1. On the LMRC-611-16M for that load, the blue Load LED will also be ON.

Config button & red LED

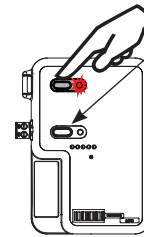

Blue LED

Blue LED ON when load is ON.

Load button:
Press & release for ON/
OFF.

Press & hold to Dim.

Step 2 Load selection

Press and release the Config button to step through the loads connected to the DLM Local Network. Each time you press the Config button, the next load in the series will turn ON along with its Load LED, and the previous load will turn OFF.

To view the current status of the button or paddle, press the button or paddle once. The LED on the paddle will blink once blue or red, and then revert to blinking red. To bind or unbind a button or paddle from the load press **and hold** that button or paddle on the LMDM-601/LMSW-6xx series switch. The LED will switch to the other color and stay lit for one second and then resume blinking red. Each time you press and hold the paddle or button, it will cycle to the next option:

- **Blue** – The button or paddle is bound to the load.
- **Red** – The button or paddle is not bound to the load.

Step 3 Exit Push n’ Learn

Press and hold the Config button until the red LED turns OFF, approximately 3 seconds.

UNIT ADJUSTMENT – SETTING OCCUPANCY SENSOR MODE TO AUTO-ON OR MANUAL-ON

The LMRC-611-16M supports the ability to configure the room between Occupancy Mode (Auto-on/Auto-off) and Vacancy Mode (Manual-on/Auto-off). Factory Default setting is Occupancy Mode.

NOTE: This feature requires firmware version 10.68 and later. Check the firmware label on unit or use DLM Config App to confirm and upgrade firmware as needed.

NOTE: Occupancy Sensor Mode will only function after the room has been paired.

1. After the room is paired using PtP, enter Occupancy Sensor Mode on any LMRC-611 series load controller by Pressing and Holding both the Config Button and Load button for 5 seconds until the Config Button LED rapidly blinks Pink. Then release both buttons.
2. To select the mode, press the Load button to toggle between Occupancy Mode (Solid Pink LED) and Vacancy Mode (Slow Blinking Pink LED)
3. To save and exit, use one of the following methods:
 - a. Press and Hold both the Load and Config Button for 5 seconds until the Config Button LED rapidly blinks Pink then release both buttons.
 - b. After 30 seconds of inactivity, the unit will exit and save automatically.
4. When exiting, the Config button LED rapidly blinks Pink and sends the change to additional load controllers in the room.

NOTE: If PtP, PnL, or Motion Test modes are used while in Occupancy Sensor Mode the unit will exit without saving.

NOTE: If additional LMRC-611 series room controllers are paired to the room after the Occupancy Sensor Mode is configured, repeat the steps above to ensure all controllers have the same settings.

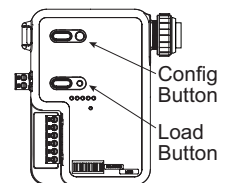

RESETTING THE LMRC-611-16M

When you reset the LMRC-611-16M, the Channel and Network ID will return to their default values. Note that if switches and sensors were previously paired to the room controller, they will still remain set to the previous Channel and Network ID, but will not be in communication with the room controller and so will not control the load. However, in a room with multiple room controllers, the other room controllers would still be paired to the switches and sensors and those loads would respond.

There are two ways to reset the LMRC-611-16M:

- Press the Config button 10 times. The LED will blink green each time the Config button is pressed (except for the 7th press which will blink blue. On the 10th press, the LED will blink red. Then it will turn red again and then briefly turn white indicating it is rebooting.
- On the front of the room controller, is a small hole that will fit a paper clip. Use a paper clip to depress the button inside that hole and hold for 15 seconds. When you first press the reset button, the LED will blink red once, then after the 15 seconds will reboot and the LED will briefly turn white, indicating it is rebooting.

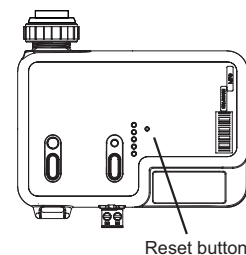

NOTE: You can also reset the LMRC-611-16M from the DLM Config App.

If you want to re-pair a room controller that has been reset, the easiest way is to use the DLM Config app, setting the room controller back to the previously used Network ID.

If using Push-to-Pair, then **if the room has only this one room controller, or if the room controller was the primary** in a network with more than one room controller, then following the standard Push-to-Pair method will return the LMRC-611-16M to the previous Network ID, since it is based on that Mac address of the room controller. But, **if the room controller was not the primary**, then you must follow the procedure for adding a new device to an existing room, with this room controller as the new device.

TROUBLESHOOTING

The wrong lights and plug loads are controlled	Configure the switch buttons and sensors to control the desired loads using the Push n' Learn adjustment procedure or DLM Config App.
LEDs on the room controller turn ON and OFF but load doesn't switch	<ol style="list-style-type: none"> 1. Make sure the DLM local network is not in PnL. 2. Check load connections to room controllers and/or plug load controllers.
Lamps do not dim, or lamps drop out at low dim levels	<ol style="list-style-type: none"> 1. Make sure a 0–10V dimming ballast and rapid start sockets are installed per the ballast manufacturer's recommendation. Shunted sockets are typically not acceptable. 2. Disconnect the 0-10V wires from the RC then-short and open the 0-10V connection to confirm the lights go full dim, full bright. 3. Check wiring per ballast manufacturer's instructions.

FCC REGULATORY STATEMENTS

This device complies with part 15 of the FCC Rules. Operation is subject to the following two conditions: (1) This device may not cause harmful interference, and (2) this device must accept any interference received, including interference that may cause undesired operation.

NOTE: This equipment has been tested and found to comply with the limits for a Class B digital device, pursuant to part 15 of the FCC Rules. These limits are designed to provide reasonable protection against harmful interference in a residential installation. This equipment generates uses and can radiate radio frequency energy and, if not installed and used in accordance with the instructions, may cause harmful interference to radio communications. However, there is no guarantee that interference will not occur in a particular installation. If this equipment does cause harmful interference to radio or television reception, which can be determined by turning the equipment off and on, the user is encouraged to try to correct the interference by one or more of the following measures:

- Reorient or relocate the receiving antenna.
- Increase the separation between the equipment and receiver.
- Connect the equipment into an outlet on a circuit different from that to which the receiver is connected.
- Consult the dealer or an experienced radio/TV technician for help.

RF exposure warning

This equipment complies with FCC radiation exposure limits set forth for an uncontrolled environment. At least 20 cm of separation distance between this device and the user's body must be maintained at all times.

Any changes or modifications not expressly approved by The Watt Stopper Inc. could void the user's authority to operate the equipment.

IC Caution:

This device complies with Industry Canada license-exempt RSS standard(s). Operation is subject to the following two conditions:

- (1) This device may not cause interference, and
- (2) This device must accept any interference, including interference that may cause undesired operation of the device.

Le présent appareil est conforme aux CNR d'Industrie Canada applicables aux appareils radio exempts de licence. L'exploitation est autorisée aux deux conditions suivantes:

- (1) l'appareil ne doit pas produire de brouillage, et
- (2) l'utilisateur de l'appareil doit accepter tout brouillage radioélectrique subi, même si le brouillage est susceptible d'en compromettre le fonctionnement.

RF exposure warning

This equipment complies with IC radiation exposure limits set forth for an uncontrolled environment. This equipment should be installed and operated with minimum distance 20cm between the radiator & your body.

Cet équipement est conforme aux limites d'exposition aux radiations de la IC définies pour un environnement non contrôlé. Cet équipement doit être installé et utilisé à une distance minimale de 20 cm entre le radiateur et votre corps.

NOTE: No rights or licenses under patents owned or controlled by third parties, express or implied, are granted to use third-party devices in combination with these products in a wireless mesh network, or to use third-party services to access, monitor or control these products in a wireless mesh network via the internet or another external wide area network. Separate license rights may need to be obtained from such third parties for such devices, combinations and services.

WARRANTY INFORMATION	INFORMATIONS RELATIVES À LA GARANTIE	INFORMACIÓN DE LA GARANTÍA
Wattstopper warranties its products to be free of defects in materials and workmanship for a period of five (5) years. There are no obligations or liabilities on the part of Wattstopper for consequential damages arising out of, or in connection with, the use or performance of this product or other indirect damages with respect to loss of property, revenue or profit, or cost of removal, installation or reinstallation.	Wattstopper garantit que ses produits sont exempts de défauts de matériaux et de fabrication pour une période de cinq (5) ans. Wattstopper ne peut être tenu responsable de tout dommage consécutif causé par ou lié à l'utilisation ou à la performance de ce produit ou tout autre dommage indirect lié à la perte de propriété, de revenus, ou de profits, ou aux coûts d'enlèvement, d'installation ou de réinstallation.	Wattstopper garantiza que sus productos están libres de defectos en materiales y mano de obra por un período de cinco (5) años. No existen obligaciones ni responsabilidades por parte de Wattstopper por daños consecuentes que se deriven o estén relacionados con el uso o el rendimiento de este producto u otros daños indirectos con respecto a la pérdida de propiedad, renta o ganancias, o al costo de extracción, instalación o reinstalación.