

WIRELESS REMOTE DIMMER & SWITCH

LINE POWERED

OVERVIEW

The line powered **SENSORWORX**® remote dimming and on/off wall stations provide manual operation of wirelessly controlled lighting. Also called companion switches, these attractive wall stations greatly reduce total installation time and wireless pairing fuss. Requiring just a few seconds per device, **SENSORWORX** wireless sensors can be linked to one or more wireless load controllers (such as the **SWX-851** wireless wall switch, **SWX-874** phase dimmer, or a **SWX-950** series wireless power pack). Additionally, these devices can be configured to work together with other wireless or wired wall stations to provide dimming and switching control from multiple locations.



FEATURES

- Pairs in Seconds with Wireless Controllers
- Powered via 120-277 VAC
- Decorator Style Fits Common Wall Plates (not included)
- Matches Styling of other SWX Sensors & Wired Wall Stations
- Enables Multiway Switching & Dimming (e.g., 3-way, 4-way)
- Intuitive Operation

SPECIFICATIONS

ELECTRICAL & WIRELESS

OPERATING VOLTAGE

120-277 VAC, Single Phase, 50/60 Hz

RANGE

80' line of site w/o obstruction (walls)
40' with obstruction (walls/floors)

FREQUENCY

915 MHz ISM Band

WIRELESS LINKING

Simple 3 sec. Push Button Process

SECURITY

All Wireless Data is Encrypted

CODE COMPLIANCE

These switches can be used to meet ASHRAE 90.1, IECC, & Title 24 energy code requirements.



ENVIRONMENTAL

OPERATING TEMP

32°F to 122°F (0°C to 50°C) - Standard
-40° F/C (with -HE Option)

RELATIVE HUMIDITY

0-95% Non-Condensing,
Indoor Use Only

PHYSICAL

SIZE

2.74"H x 1.68"W x 1.39"D
(6.96 x 4.27 x 3.53 cm)

Fits Decorator Switch Plate Opening

WEIGHT

2.5 oz

MOUNTING

Single Gang Switch Box

MISC

COMPATIBLE LOAD CONTROLLERS

SWX-851 Wall Switch
SWX-874 Phase Dimmer
SWX-950/951 Series Power Packs

ORDERING INFO

SAMPLE MODEL # SWX-854-2-WH

MODEL & DESCRIPTION

SWX-854-2* Wireless Remote Dimmer & Switch (On/Off/Raise/Lower), Line Powered (120-277 VAC)
Note, unit is a companion switch only and not a load controller.

SWX-852-2* Wireless Remote Switch (On/Off), Line Powered (120-277 VAC)
Note, unit is a companion switch only and not a load controller.

SWX-199 Single Gang Wall Plate

COLOR *

White - **WH**
Ivory - **IV**
Light Amond - **LA**
Gray - **GY**
Black - **BK**

OPTION

Low Temp / - **HE**
High Humidity

PACKAGE COUNT

Single Pack
10 Pack**

Blank
- **J10**

**Wallplate not included

APPLICATIONS

Adding a wireless remote wall switch to a room controlled by a wireless power pack (SWX-950) and a wireless sensor (e.g. SWX-221-B) enables code compliant vacancy (manual on) operation. When linked with a wireless dimming power pack (SWX-950-D2), a remote wireless dimmer is perfect for providing user control of 0-10V dimmable lighting. Additional remote dimmer switches can be linked enabling user control from multiple locations. Linking a remote wireless switch to a wireless wall switch load controller (SWX-851) or phase dimmer (SWX-874) enables 3-way user control as well.

- Classrooms
- Open Areas
- Conference Rooms
- Hallways
- Small Offices
- Copy Rooms
- Private Restrooms
- Break Rooms

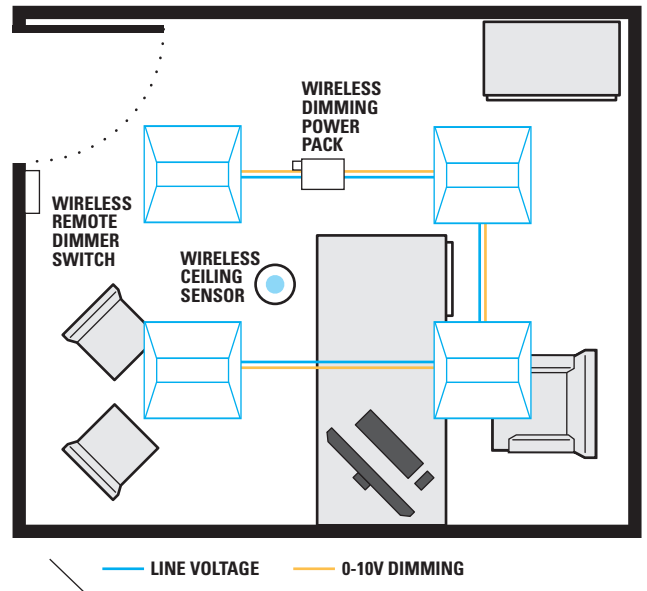

OPERATION NOTES

- Wireless remote switches and dimmers only transmit when a button is being pressed.
- The unit's blue LED will light only when a button is pressed.
- The dim up and dim down buttons may be held down to increase dimming rate.
- There are always 20 equal steps of dim level (voltage) adjustment from high trim to low trim (or reverse) when using a SWX-854-2 wireless remote dimmer.

INSTALLATION

- Designed to mount in 1-gang wall box with 3.28" hole spacing.
- Units can also share multiple gang wall boxes with other devices.

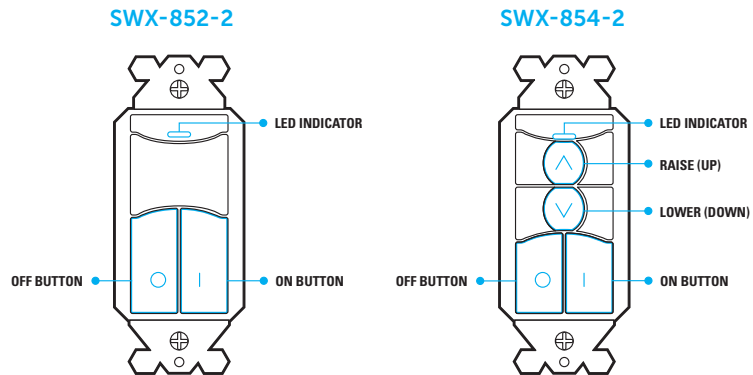

WIRING

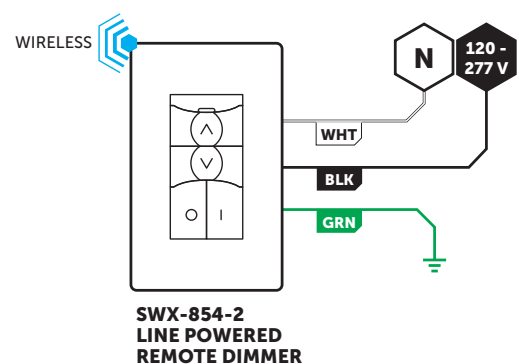
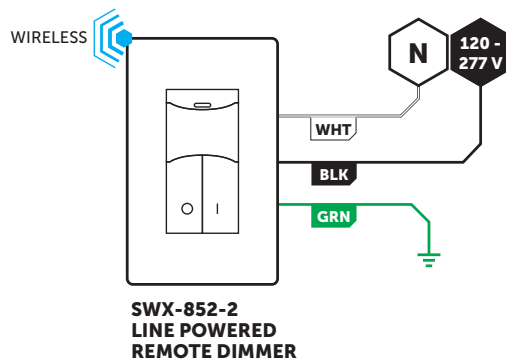

COMPATIBLE WIRELESS DEVICES

The below chart lists the devices that can be used in a **SENSORWORX** wireless application. Note that sensors and remote switch & dimmer devices are transmit only devices and therefore must be linked to a load controller for switching or dimming of lighting.

MODEL #	DESCRIPTION	WIRELESS TYPE	POWER TYPE
SWX-201-B	Small Motion 360° Sensor, PIR	Transmit	Battery
SWX-211-B	Small Motion 360° Sensor, PIR w/ Integrated Daylight Harvesting Photocell	Transmit	Battery
SWX-221-B	Dual Technology Sensor (PIR/Acoustic), Small Motion 360°	Transmit	Battery
SWX-401-B	Wide View Sensor, PIR	Transmit	Battery
SWX-421-B	Dual Technology (PIR/Acoustic) Wide View Sensor	Transmit	Battery
SWX-402-B	Long Range Hallway Sensor, PIR	Transmit	Battery
SWX-250-B	Daylight Harvesting & On/Off Photocell	Transmit	Battery
SWX-851-xx	Wall Switch Load Controller, No Neutral Required, <xx = color>	Transmit & Receive	120-277 VAC
SWX-852-B-xx	Remote Switch (On/Off), <xx = color>	Transmit	Battery
SWX-852-2-xx	Remote Line Powered Switch (On/Off), <xx = color>	Transmit	120-277 VAC
SWX-854-B-xx	Remote Dimming Switch (On/Off, Raise/Lower), <xx = color>	Transmit	Battery
SWX-854-2-xx	Remote Line Powered Dimming Switch (On/Off, Raise/Lower), <xx = color>	Transmit	120-277 VAC
SWX-874-ELV-xx	Phase Dimming Load Controller - Reverse (default) or Forward Phase, <xx = color>	Transmit & Receive	120 VAC
SWX-950	Power Pack Load Controller, 20A	Transmit & Receive	120/277 VAC
SWX-951-D1	Fixture Controller, 1A@, 0-10V Dimming	Transmit & Receive	120-277 VAC
SWX-950-D1	Power Pack Load Controller, 20A, 0-10V Dimming (Class 1)	Transmit & Receive	120/277 VAC
SWX-950-D2	Power Pack Load Controller, 20A, 0-10V Dimming (Class 2)	Transmit & Receive	120/277 VAC
SWX-950-AX	Hybrid Wireless/Wired Power Pack Load Controller, 20A	Transmit & Receive	120/277 VAC
SWX-950-AX-D2	Hybrid Wireless/Wired Power Pack Load Controller, 20A, 0-10V Dimming	Transmit & Receive	120/277 VAC

WIRELESS PAIRING

Pairing a remote dimmer/switch with a wireless wall switch load controller or power pack load controller is quickly done via the following procedure:

1. Enter pairing mode by holding down the wireless load controller's button for 3 seconds until the LED starts alternating white then blue.
2. At the remote dimmer/switch, hold down the ON button for 3 seconds until the LED starts alternating white then blue. Releasing will pair the device with the controller in pairing mode (see note 1 below). The lights will toggle once as confirmation.
3. If additional remote dimmers or switches need to be linked, repeat step 2.
4. When all devices have been paired, close pairing mode on the wireless load controller by pressing the button 1 time. Pairing will also be automatically closed after 15 minutes of no new devices being linked.

Note 1: When in pairing mode, the alternating LED colors on the wireless load controller will periodically pause and blink out the total number of paired devices. There will be no blinks during the pause until the first device is linked.

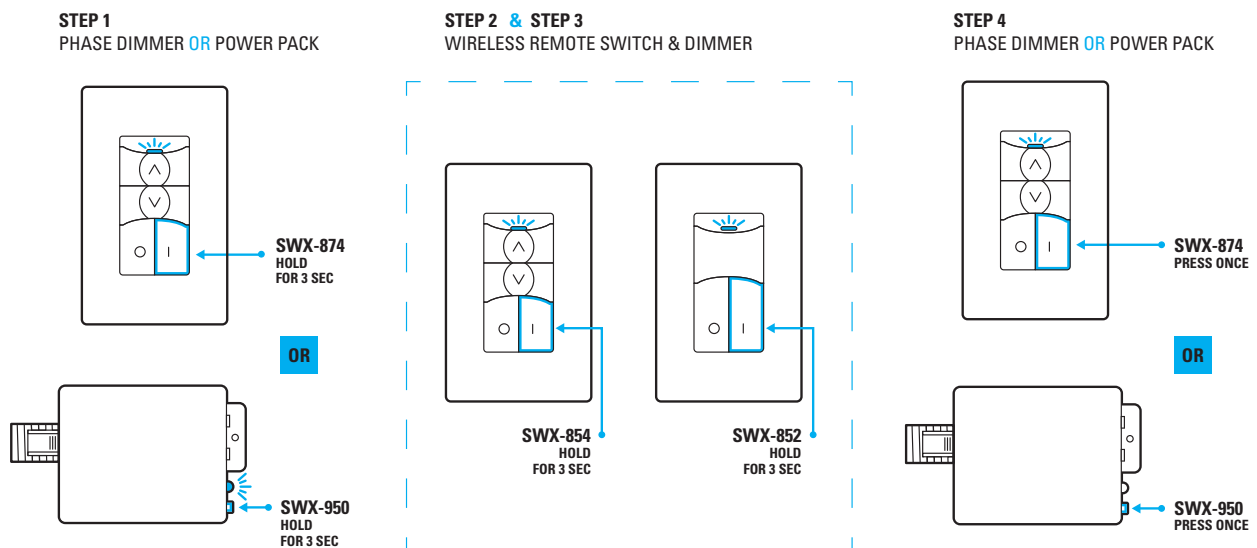

FCC INFORMATION (FCC ID: 2AVRY-SWX0001)

This device complies with Part 15 of the FCC Rules. Operation is subject to the following conditions:

1. This device may not cause harmful interference, and
2. This device must accept any interference received, including interference that may cause undesired operation

Changes and Modifications not expressly approved by BLP Technologies can void your authority to operate this equipment under Federal Communications Commission's rules.

In order to comply with FCC/ISED RF Exposure requirements, this device must be installed to provide at least 20 cm separation from the human body at all times.

This equipment has been tested and found to comply with the limits for a Class B digital device, pursuant to Part 15 of the FCC Rules. These limits are designed to provide reasonable protection against harmful interference in a residential installation. This equipment generates uses and can radiate radio frequency energy and, if not installed and used in accordance with the instructions, may cause harmful interference to radio communications. However, there is no guarantee that interference will not occur in a particular installation. If this equipment does cause harmful interference to radio or television reception, which can be determined by turning the equipment off and on, the user is encouraged to try to correct the interference by one of the following measures:

- Reorient or relocate the receiving antenna.
- Increase the separation between the equipment and receiver.
- Connect the equipment into an outlet on a circuit different from that to which the receiver is connected.
- Consult the dealer or an experienced radio/TV technician for help

ISED CANADA INFORMATION (IC: 26012-SWX0001)

This device contains licence-exempt transmitter(s)/receiver(s) that comply with Innovation, Science and Economic Development Canada's licence-exempt RSS(s). Operation is subject to the following two conditions:

1. This device may not cause interference.
2. This device must accept any interference, including interference that may cause undesired operation of the device.

In order to comply with FCC/ISED RF Exposure requirements, this device must be installed to provide at least 20 cm separation from the human body at all times.

L'émetteur/récepteur exempt de licence contenu dans le présent appareil est conforme aux CNR d'Innovation, Sciences et Développement économique Canada applicables aux appareils radio exempts de licence. L'exploitation est autorisée aux deux conditions suivantes :

1. L'appareil ne doit pas produire de brouillage;
2. L'appareil doit accepter tout brouillage radioélectrique subi, même si le brouillage est susceptible d'en compromettre le fonctionnement.
3. Afin de se conformer aux exigences d'exposition RF FCC / ISED, cet appareil doit être installé pour fournir au moins 20 cm de séparation du corps humain en tout temps

