



The Advance Xtanium Sensor Ready (SR) LED driver can help reduce complexity and cost of light fixtures used in connected lighting systems for indoor lighting applications. It's D4i certified and features a standard-compliant digital interface to enable direct connection to compatible networked lighting control (NLC) solutions. The minimum dimming level has been improved to be as low as 1%. Advanced lighting control functionalities that ordinarily would require additional auxiliary component are integrated into this driver. The result is a simple, cost-effective light fixture that supports the most advanced smart lighting use cases.

Specifications

Input Volt. (Vac)	Output Power (W)	Output Voltage (V)	Output Current (A)	Efficiency @ Max Load and 70°C Case (%)	Max Case Temp. (°C)	Input Current (A)	Max. Input Power (W)	THD @ Max Load	Power Factor @ Max Load	Surge Protect. (Ring Wave, KV)	Envir. Protect. Rating	Dim.	Dim. Range (with specified dimmers)	Min. Output Current (A)	Driver Type
120	50	10 – 54 Class 2 Output	0.1 – 1.4	87%	Life – 75°C UL – 85°C	0.48	59	<10%	>0.95	2.5	UL damp & dry	DALI	1% ~ 100%	0.004	Constant Current
277				88%		0.21		<15%							

Enclosure

	In (mm)	Tolerance (mm)
Overall Length (A1)	14.17 (359.8)	±0.5
Mounting Hole Distance (A2)	13.78 (350)	±0.5
Case Length (A3)	11.87 (301.5)	±0.5
Case Width (B1)	1.18 (29.4)	±0.5
Case Height (B1)	1.0 (25.4)	±1.0
Mounting Hole Diameter (D1)	0.31 (7.9)	±0.3
Center of SimpleSet Antenna (G1)	0.84 (21.3)	±3.0

Wiring Diagram

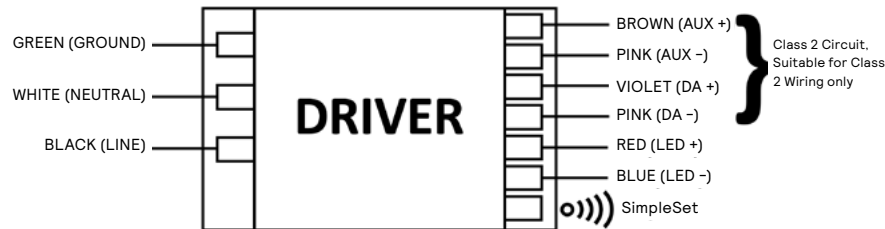

WARNING

Install in accordance with national and local electrical codes. The Filed-wiring leads or push-in terminals shall be fully enclosed. Use 18 AWG Solid Copper Wire Rated ≥ 90 °C. Strip Wire 3/8". For Class 2 wiring, use 20 AWG - 16 AWG.

GROUNDING

Driver case must be grounded.

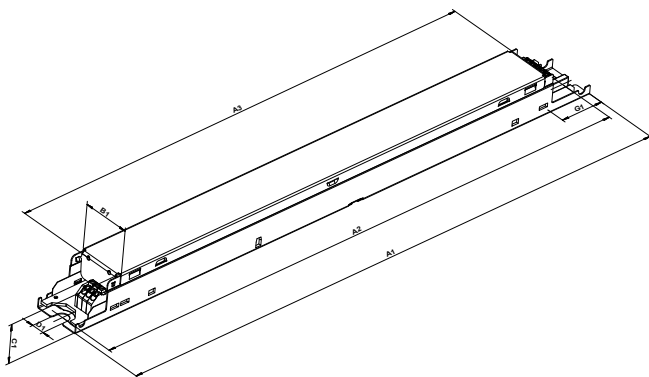

Xitanium SR XI050C140V054VST1

50W 1.4A SR 54V (1%) with SimpleSet Aux D4i

Features

- Standard-compliant (ANSI C137.4 and DiiA) digital interface including:
 - Integrated DALI bus power supply (Part 250)
 - Memory Bank 1 extension, Energy Monitoring and Diagnostics (Parts 251, 252, 253)
- Energy metering and advanced diagnostics
- Continuous dimming down to 1%
- Drive current setting via SimpleSet wireless programming
- 5-year limited warranty*
- Auxiliary Power supply(12/24V selectable, default 24V)

Benefits

- Enable interoperability with diverse wireless sensors/network systems
- Reduce complexity and cost of fixture by eliminating auxiliary components ordinarily required for powering sensors, switching fixture off and monitoring energy use
- Future proof through standard interface to any suitable sensor and ease of adjustable drive current

Application

- Indoor linear applications such as troffers and pendants

Product Data

All specifications are typical and at 25°C Tcase unless otherwise specified.

Order Information	
Order Code	XI050C140V054VST1M (Mid-Pack, 18pcs/Box), 12NC: 929002739313
GTIN	781087168394
Input Information	
Line Frequency	50/60Hz
Min. Mains Voltage Operational	108Vac
Max. Mains Voltage Operational	305Vac
Output Information	
Maximum Open Circuit Voltage	<60Vdc
Output Current Ripple (ripple = peak to average / average)	15% max @ max Iout 4% max @ Visible for Stroboscopic Frequency range 60Hz-3KHz
Pst/SVM	NEMA77 Compliant
Output Current Tolerance	<5%
Protections	Short Circuit, Open Circuit Protection for LED + and LED - and Temperature Foldback
Control Lead Leakage Current (SR)	0.01mA, recommended max number of control circuits in parallel, refer to Design In Guides
Features	
AOC (Adjustable Output Current)	0.1A-1.4A via SimpleSet (Factory Default at 1.4A)
Suitable for Outdoor Use?	No
Interfaces	SimpleSet, Sensor Ready(SR)
Power Reporting Accuracy	+/-4% in performance window and under nominal operating conditions
Configurable Features	Adjustable Light Output (ALO) Adjustable Output Current (AOC) Constant Light Output (CLO) DiiA specification DALI Part 253 - Luminaire Maintenance (DALI 253 M) Luminaire (Fixture) Information (Luminaire Info) OEM Write Protected features (OWP) SR Power Supply (SR PSU)
SR power supply	
Current Source	52mA to 60mA
Voltage Range	12V to 20V
Communication Protocol	DALI-2, D4i, ANSI C137.4
Mis-wiring to Mains Protection	No

Xitanium SR XI050C140V054VST1

50W 1.4A SR 54V (1%) with SimpleSet Aux D4i

Environment & Approbation	
Operating Ambient Temp. Range	-20°C to +50°C
Max Case Temperature (Tcase)	85°C
Agency Approbations	UL, cUL, FCC, NOM, Class P (UL, cUL)
Electromagnetic Compliance	FCC Title 47 Part 15 Class A
Audible Noise	<24dB Class A
Weight	0.638Lbs/0.29Kgs
Envir. Protection Rating	UL Dry and Damp

*1. Advance Xitanium LED drivers are designed and manufactured to engineering standards correlating to an average life expectancy of 50,000 hours of operation at maximum rated case temperature. Minimum 90% survivals based on MTTF modeling

Electrical Specifications

All the specifications are typical and at 25 °C Tcase unless specified otherwise.

SR Power Supply Characteristics (Typical)

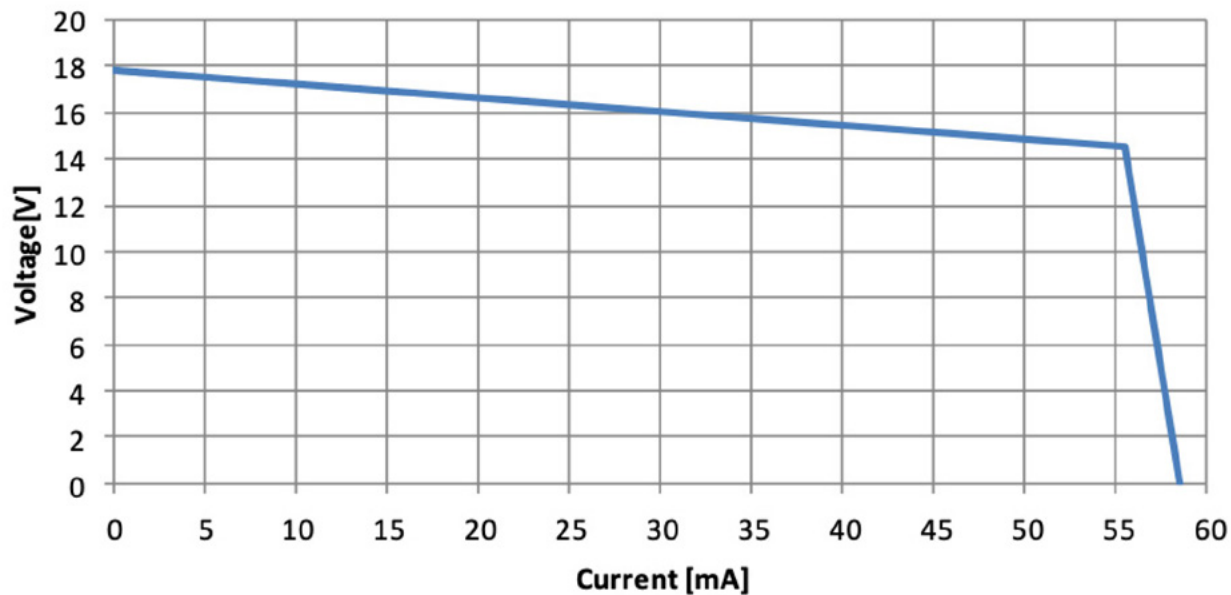

Note:

Power supply through digital connection, default "on," for connection of one driver to one sensing/RF device. Consult your representative for use with multiple devices.

12/24V Auxilliary Power Supply

Symbol	Parameter	Condition	Min.	Typical	Max.	Unit
Vaux	Aux power supply nominal output voltage (programmable)	Steady state and during pulse	10.8 21.6	12 24	13.2 26.4	V
Iaux	Steady state Average output current	12V 24V	0 0		100 50	mA
Vaux_p_p	Maximum output voltage ripple p-p				1	%
Vaux_max	Transient output voltage range		-25%		25	%

Xitanium SR XI050C140V054VST1

50W 1.4A SR 54V (1%) with SimpleSet Aux D4i

Electrical Specifications

All the specifications are typical and at 25°C Tcase unless specified otherwise.

Dimming Characteristics

Dimming is accomplished through the 2-wire DALI connection to the sensor. DALI standard IEC62386_102 Edition 2 defines the logarithmic dimming curve. DALI standard IEC62386_107 Edition 1 defines the linear dimming curve as well as the command for switching between logarithmic and linear curves (Default = Logarithmic).

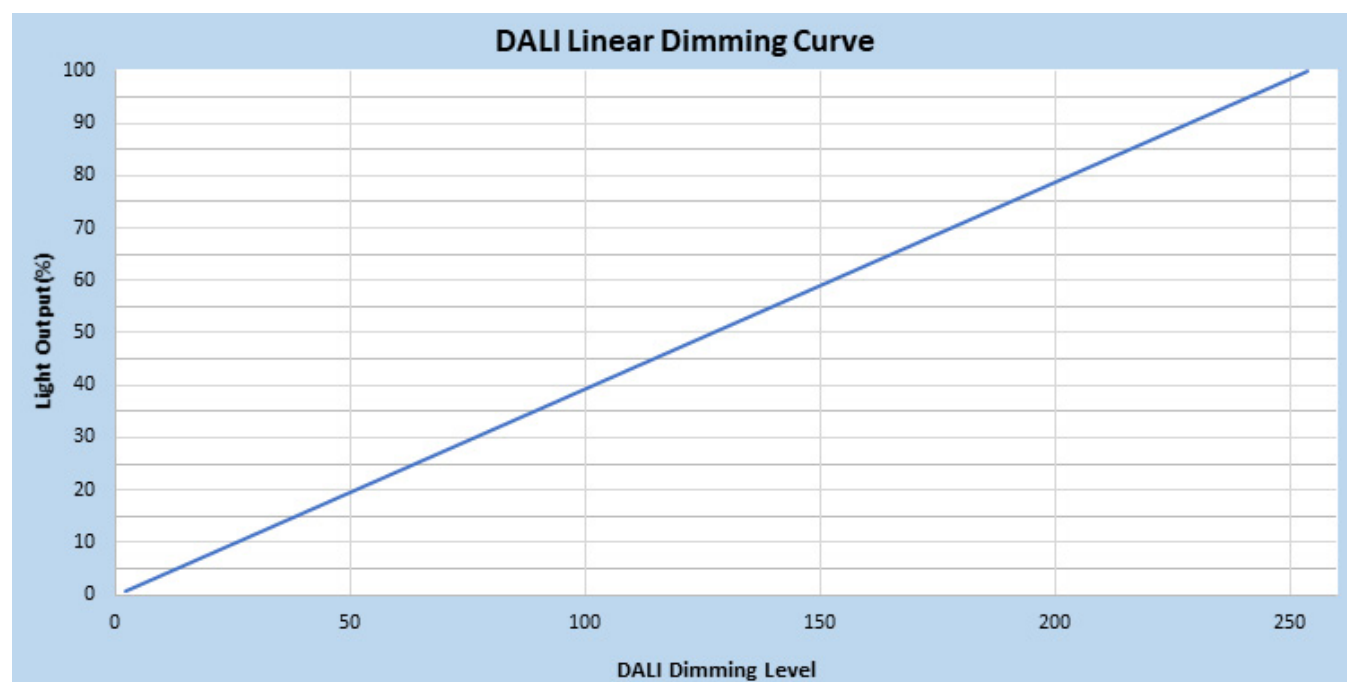
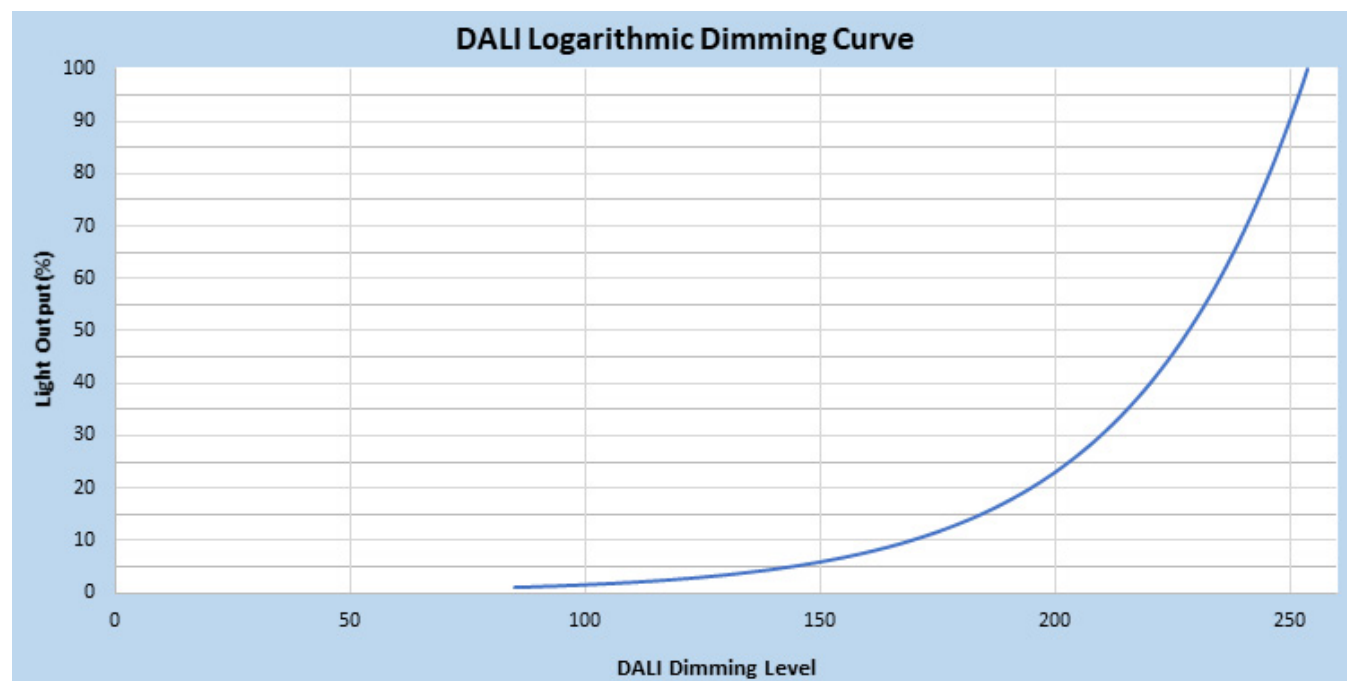

Xitanium SR XI050C140V054VST1

50W 1.4A SR 54V (1%) with SimpleSet Aux D4i

Electrical Specifications

All the specifications are typical and at 25°C Tcase unless specified otherwise.

Operating Window

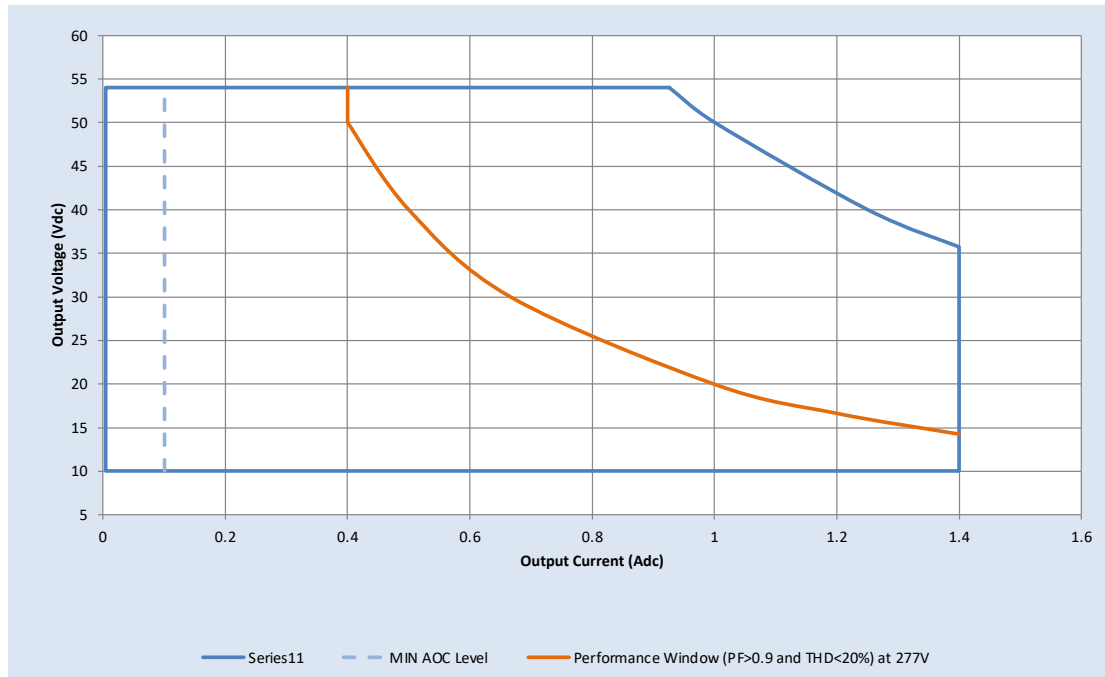

Note:

1. Factory default output current is 1.4A.
2. To get a 100% to 1% dimming range, the output current setting through AOC should be $\geq 0.4A$.

Xitanium SR XI050C140V054VST1

50W 1.4A SR 54V (1%) with SimpleSet Aux D4i

Performance Characteristics

Based on measurements on a typical sample. The accuracy of the measurements is within the tolerance of the measurement instruments. The graphs are meant to be a guideline and not a specification.

Output Current Vs. Driver Case Temperature

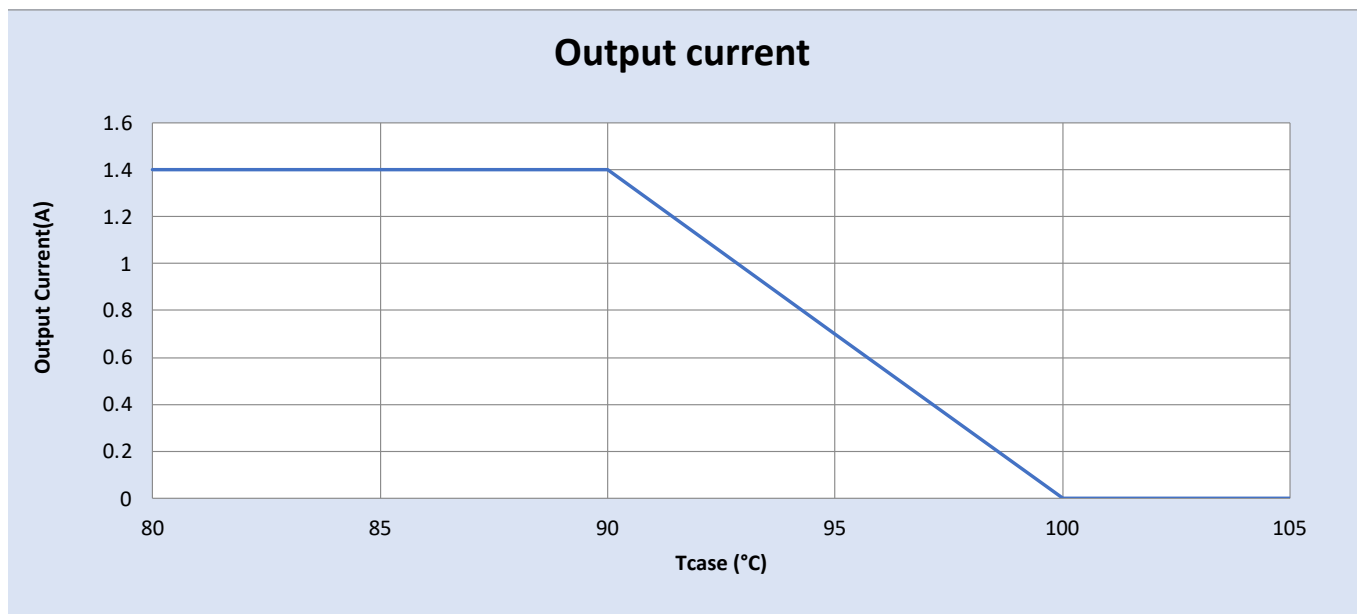

Note: There is $\pm 5^{\circ}\text{C}$ tolerance on the driver case temperature

Driver Lifetime vs. Driver Case Temperature

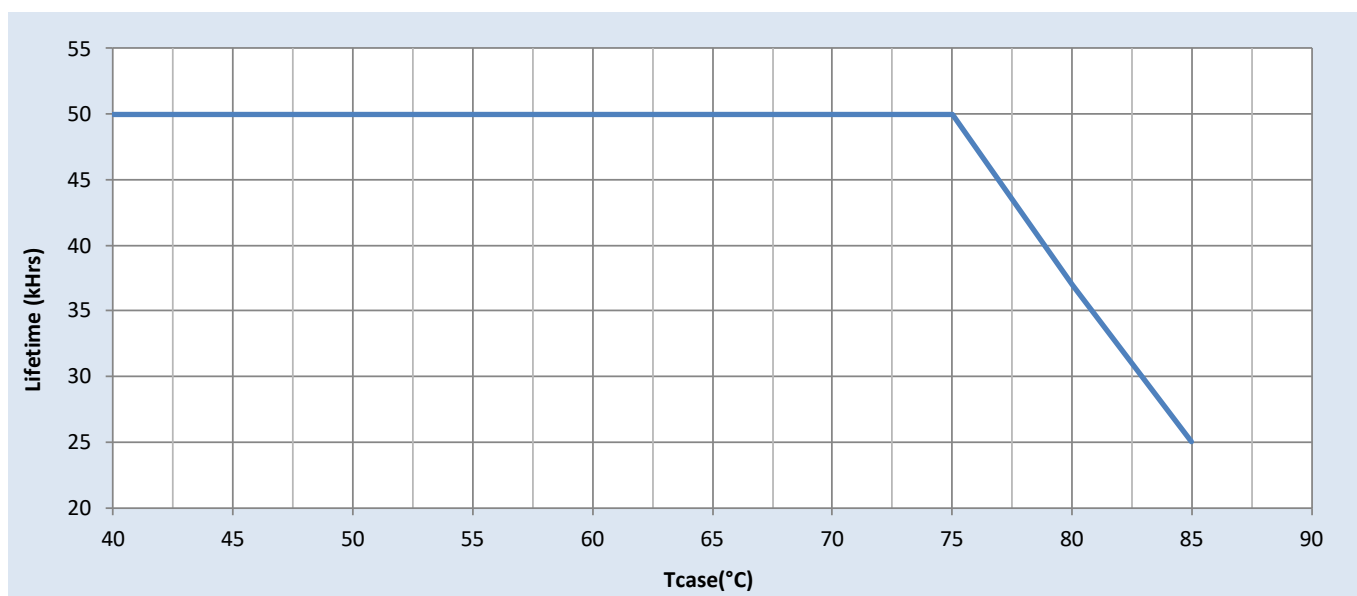

Xitanium SR XI050C140V054VST1

50W 1.4A SR 54V (1%) with SimpleSet Aux D4i

Performance Characteristics

Based on measurements on a typical sample. The accuracy of the measurements is within the tolerance of the measurement instruments. The graphs are meant to be a guideline and not a specification.

Efficiency Vs. Output Voltage at 120Vac

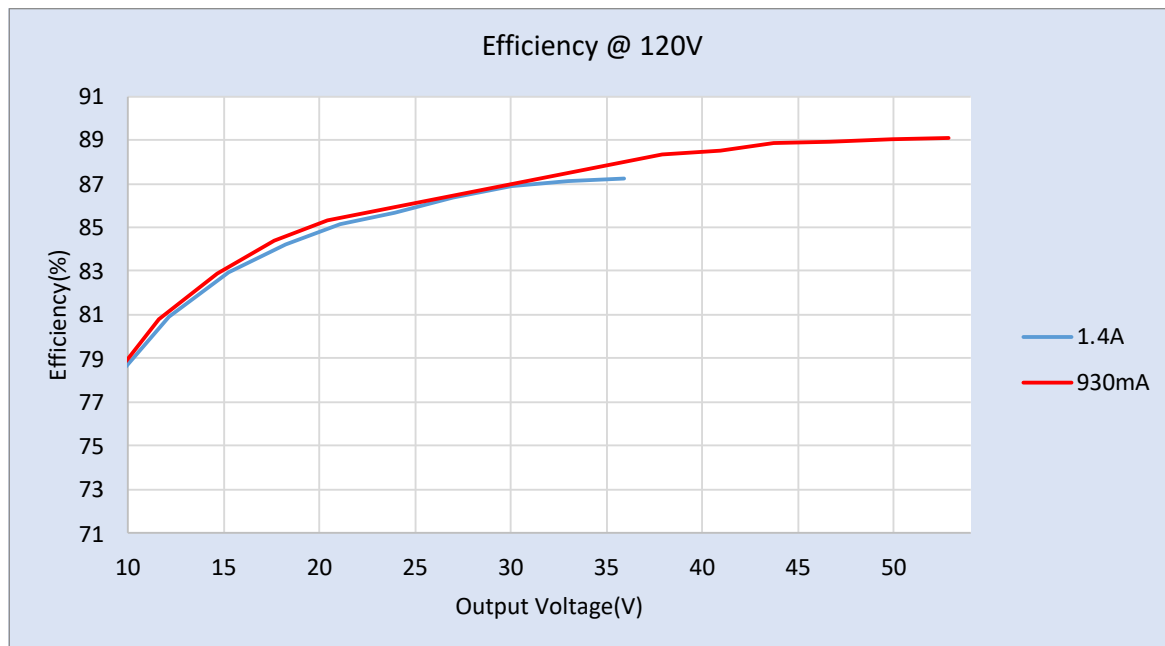

Efficiency Vs. Output Voltage at 277Vac

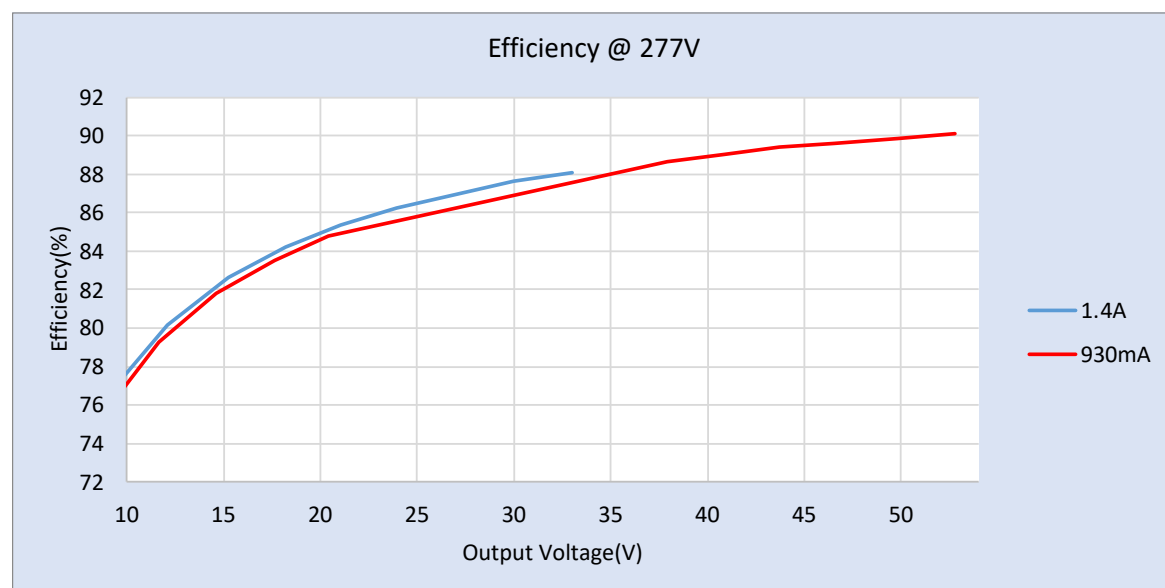

Xitanium SR XI050C140V054VST1

50W 1.4A SR 54V (1%) with SimpleSet Aux D4i

Performance Characteristics

Based on measurements on a typical sample at 75°C case. The accuracy of the measurements is within the tolerance of the measurement instruments. The graphs are meant to be a guideline and not a specification.

Power Factor vs. Output Power

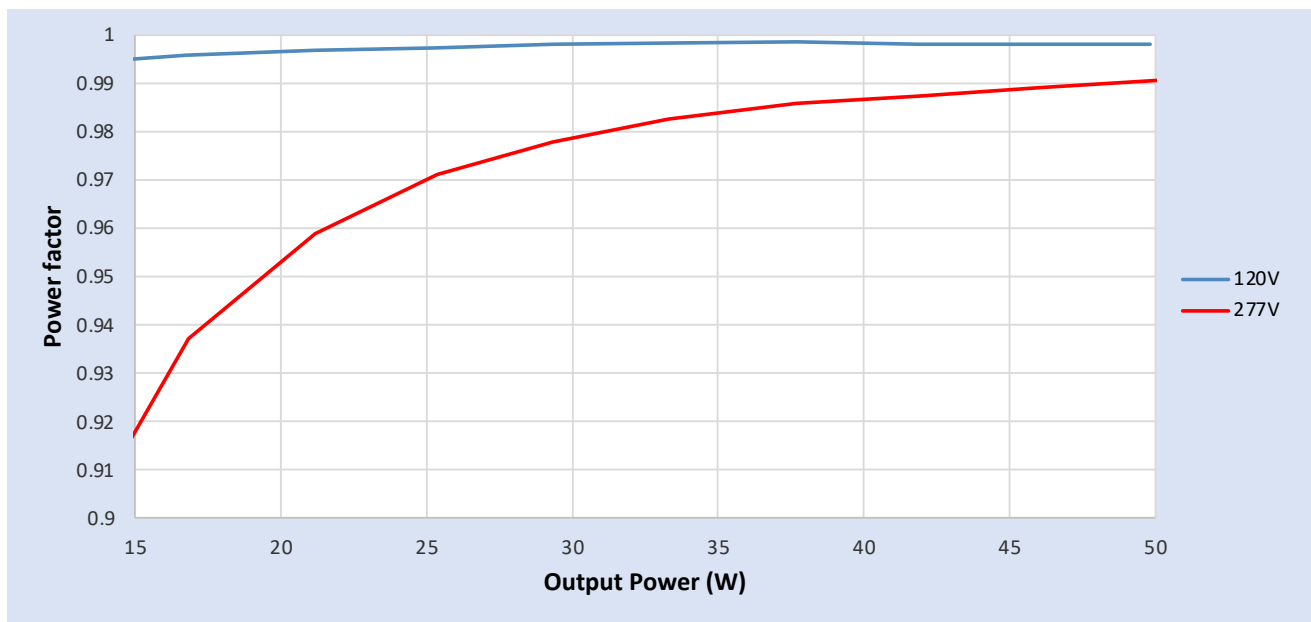

Total Harmonic Distortion vs. Output Power

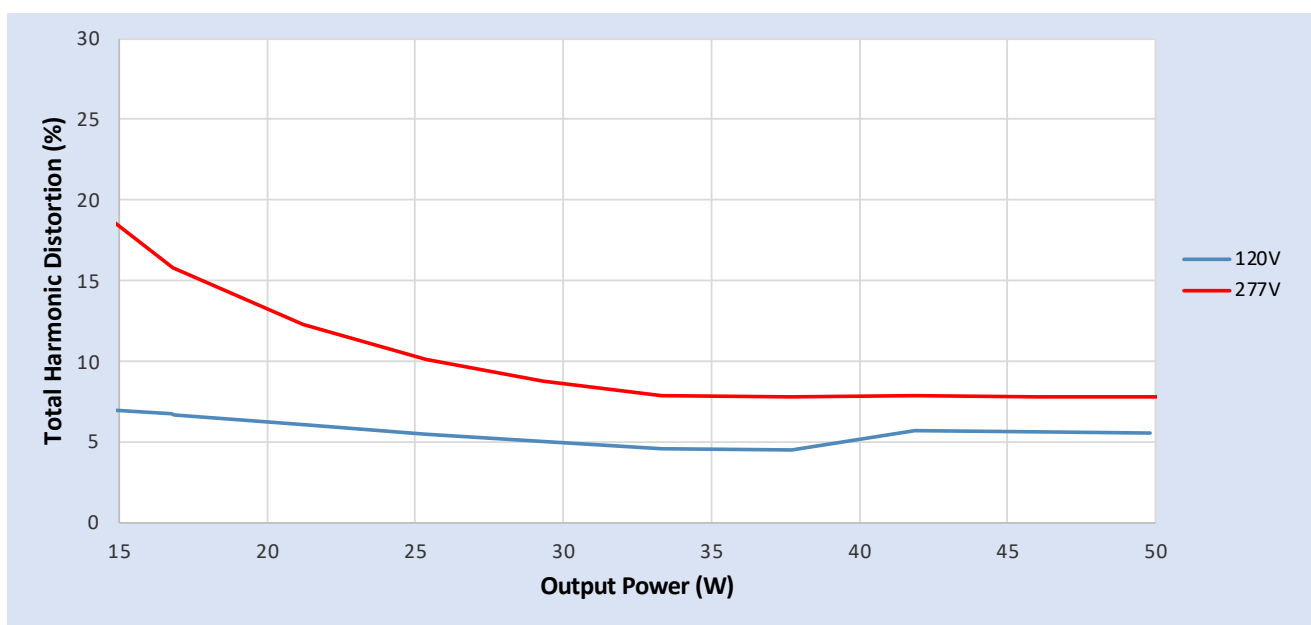

Note:

PF>0.9, THD<20%.

Xitanium SR XI050C140V054VST1

50W 1.4A SR 54V (1%) with SimpleSet Aux D4i

Inrush Current Info

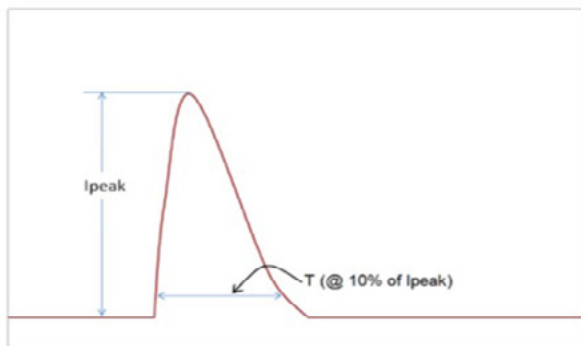

Vin	I _{peak}	T (@10% of I _{peak})
120 Vrms	12.4A	48μs
277 Vrms	17.4A	40μs

Lightning Surge Info

ANSI Surge Type	Differential Mode (L-N)	Common Mode (L-G, N-G, L&N-G)
100 kHz Ring Wave (w/t 30Ω)	2.5kV	2.5kV

Isolation:

Isolation	Input	Output	DALI/Aux	Enclosure
Input	-	2XU+1000Vac	2XU+1000Vac	2XU+1000Vac
Output	2XU+1000Vac	-	500Vac	500Vac
DALI/Aux	2XU+1000Vac	500Vac	-	500Vac
Enclosure	2XU+1000Vac	500Vac	500Vac	-

U=Maximum input Voltage

The information presented in this document is not intended as any commercial offer and does not form part of any quotation or contract.



© 2022 Signify Holding. All rights reserved. The information provided herein is subject to change, without notice. Signify does not give any representation or warranty as to the accuracy or completeness of the information included herein and shall not be liable for any action in reliance thereon. The information presented in this document is not intended as any commercial offer and does not form part of any quotation or contract, unless otherwise agreed by Signify.

Signify North America Corporation
400 Crossing Blvd, Suite 600
Bridgewater, NJ 08807
Telephone: 855-486-2216

Signify Canada Ltd.
281 Hillmount Road,
Markham, ON, Canada L6C 2S3
Telephone: 800-668-9008