

KT-EM-TP2-XXWL-SU-RC

EXIT SIGN

INSTALLATION INSTRUCTIONS

PLEASE FIND A QUALIFIED ELECTRICIAN FOR INSTALLATION. Please read the instructions before you install and use the fixture.

SAFETY AND ELECTRICAL PARAMETERS

WARNING:

- FAILURE TO FOLLOW THESE INSTRUCTIONS AND WARNINGS MAY RESULT IN DEATH, SERIOUS INJURY OR SIGNIFICANT PROPERTY DAMAGE. For your protection, read and follow these warnings and instructions carefully before installing or maintaining this equipment. These instructions do not attempt to cover all installation and maintenance situations.
- RISK OF ELECTRIC SHOCK – NEVER CONNECT TO, DISCONNECT FROM, OR SERVICE WHILE EQUIPMENT IS ENERGIZED.
- RISK OF FIRE. Lamps are hot. Keep combustible material away from hot parts. Observe warnings, recommendations and restrictions on lamp operation and maintenance. Make sure lamps are correctly installed.

CAUTION:

- The battery in this unit may not be fully charged. After electricity is connected to unit, let battery charge for at least 24 hours, then normal operation of this unit should take effect.

IMPORTANT SAFEGUARDS:

When using electrical equipment, basic safety precautions should always be followed, including:

- Do not use outdoors. Suitable for use in 32°F–104°F (0°C–40°C) indoor damp locations.
- Consult local building code for approved wiring and installation.
- Disconnect AC power before servicing and installation.
- Do not mount near gas or electric heaters.
- Do not use this equipment for anything other than its intended use.
- The use of accessory equipment not recommended by the manufacturer will void product listing and warranty and may cause an unsafe condition.
- Any service on this equipment should be performed by qualified personnel only.
- Equipment should be mounted in locations and at heights where it will not be subject to tampering by unauthorized personnel.
- Use caution when servicing batteries.
- Cap unused wires with enclosed wire nuts or other approved method.
- Make sure wire terminations are secure and leads are properly tucked in appropriate wire channels.

IMPORTANT CODE COMPLIANCE INFORMATION:

In accordance with NFPA 101 (current Life Safety Code), documented testing of your emergency lighting system must be tested monthly for a minimum of 30 seconds and annually for 90 minutes. Refer to your local codes for any additional requirements that may apply.

WIRING DIAGRAMS

GENERAL WIRING DIAGRAM

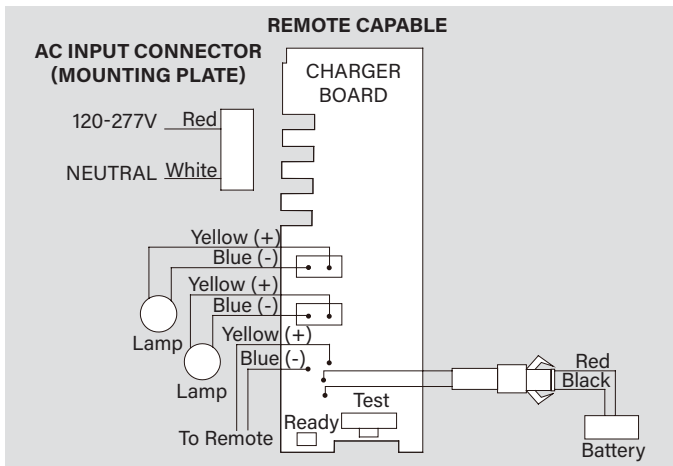

COMPONENTS INCLUDED IN KIT

Part
1x Lighting Fixture
1x Extension Wire (45cm) for Remote Heads
1x Rechargeable Battery
1x Mounting Hardware & Connection Accessory Kit

Caution: Before installing, ensure that AC power to the fixture is off.
Caution: The electrical rating of this product is 120–277V. Installer must confirm that there is 120–277V at the fixture before installation.

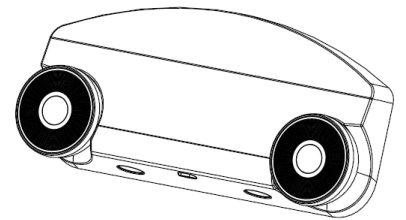

INSTALLATION INSTRUCTIONS

SURFACE MOUNT

1. Remove back panel by pressing two snaps at bottom of fixture (Fig. C). Drill or knockout appropriate knockouts on back panel for mounting and wiring.
2. Feed fixture leads through back panel and make wiring connections(Fig A). Push wire connections into junction box.
3. Secure back panel to junction box.
4. Connect battery (Fig. B).
5. Align snaps and push housing directly onto back panel (Fig. C). Apply continuous AC power and press TEST button to check light.

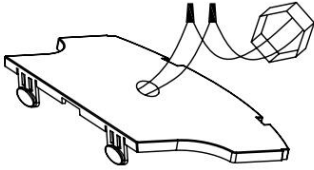

Fig.A(J-BOX)

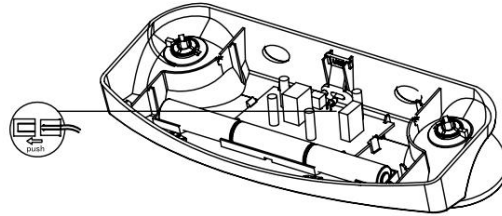

Fig.B

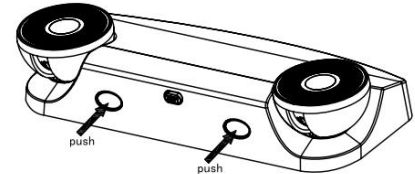

Fig.C

CONDUIT

1. Secure back panel to wall surface. Route wires through hole in conduit flange and make conduit connection.
2. Align snaps and push housing directly onto back panel (Fig. C). Apply continuous AC power and press "TEST" button to check light.

WARNING: Unused wires must be capped using enclosed wire nuts.

USE WITH OPTIONAL REMOTE HEADS

This emergency light is remote capable. It is equipped with a large battery to provide power to up to two additional remote single heads or a single remote double head.

To install optional remote head(s):

1. During installation wiring above (step 2), wire remote head extension wire to the third pair of Yellow (+) and Blue (-) connections.
2. Route extension wire to location for additional mounted head. If installing two separate remote heads, wire to each head individually from the main fixture. Connect Yellow (+) to the positive wire of the remote head(s), and Blue (-) to the negative wire of the remote heads.
3. When pressing the "TEST" button, the main fixture and any connected remote heads should all turn on.

OPERATION (BATTERY BACKUP)

1. Apply AC power to the unit. The LED indicator will be RED.
2. After the battery has been left to charge for 24 hours, test the unit by pushing the switch. The LED indicator will turn OFF and the lights will remain illuminated.
3. When the switch is released, the LED indicator will turn back to RED and the lights will turn off.

MAINTENANCE

CAUTION: Always turn off AC power to the equipment before servicing. Servicing should be performed only by a qualified service technician. Use only MANUFACTURER supplied replacement parts.

BATTERY: The battery supplied requires no maintenance. However, it should be tested periodically and replaced when it no longer operates the connected sign for the duration of a 30 second or 90 minute test. The battery supplied in this sign has a typical life of 5 years when used in a normal ambient temperature of 72°F.