



KTLD-100-UV-24V-MC2

CONSTANT VOLTAGE LED DRIVER

DESCRIPTION

Class 2  **SAM**  **FC**   **10 YEAR LIMITED WARRANTY**

TOTAL POWER: 100W
INPUT VOLTAGE: 120/277Vac ± 10%
INPUT FREQUENCY: 50/60 Hz
OUTPUT VOLTAGE: 24V
DIMMING: Fixed Output
WARRANTY: 5 Years
LOCATION: Suitable for dry and damp locations



ELECTRICAL SPECIFICATIONS

Input Voltage Range	120/277Vac ± 10%
Frequency	50/60 Hz
Power Factor	> 0.9 under 120/277Vac input with 80~100% load condition
Max. Input Current	1.05A @120V, 0.58A @230V and 0.48A @277V
THD	≤ 20% under 120/277Vac input with 80~100% load condition
Output Tolerance	± 5% at Full Load Condition
Turn-On Delay Time	≤ 0.5s at Full Load Condition
Overshoot	< 10% at Full Load Condition
Ripple & Noise (pk-pk)	≤ 5% of rated output voltage for each model
Leakage Current	400 μA @120V, 800μA @230V, 920μA @ 277V
Protection	<ul style="list-style-type: none"> Under-Voltage (Brownout): Provides protection circuitry such that an application of an input voltage below the minimum stated in above shall not cause damage to the driver. Short Circuit and Over Current Protection: Protected against short-circuit such that a short from any output to return shall not result in a fire hazard or shock hazard. The driver shall hiccup as a result of a short circuit or over current fault. Removal of the fault will return the driver to within normal operation. The driver shall recover, with no damage, from a short across the output for an indefinite period of time. Internal Over temperature Protection: Equipped with an internal temperature sensor on the primary power train. Failure to stay within the convection power rating will cause the driver to shut down. The main output current will be resumed when the temperature of the built-in temperature sensor cools adequately. Output Open Load : A no load condition will not damage the driver or cause a hazardous condition. The driver will remain stable and operate normally after application of a load. When the LED load is removed, the output voltage of the driver is limited to about 7% of the output voltage of each model. Input Over Current Protection: Incorporates a primary AC line fuse for input over current protection.

ENVIRONMENTAL SPECIFICATIONS

Operating Temperature	-20 to 50°C
Storage Temperature	-40 to 85°C
Humidity	5% to 95%
MTBF	> 200,000 hours when operated at nominal input and output conditions, and at Tc ≤ 70°C
Life Rating	50,000 hours at Tc ≤ 70°C maximum case hot spot temperature
Maximum Case Temperature	90°C/194°F
Maximum Case Temperature (tc) for 5-Year Warranty	70°C/158°F

SAFETY AND EMC COMPLIANCE

UL/cUL	UL 8750, Class P, Class 2
FCC, 47CFR Part 15	Meets Class B @ 120V and Class A @ 277V



KTLD-100-UV-24V-MC2

CONSTANT VOLTAGE LED DRIVER

PRODUCT SPECIFICATIONS

Catalog Number	Max. Output Power	Output Current	Output Voltage	OCV	Typical Efficiency at 120V	Typical Efficiency at 240V	Typical Efficiency at 277V	Class 2	
								US	Canada
KTLD-100-UV-24V-MC2	96W	4A	24V	25.7V	89%	92%	92%	✓	✓

PHYSICAL SPECIFICATIONS

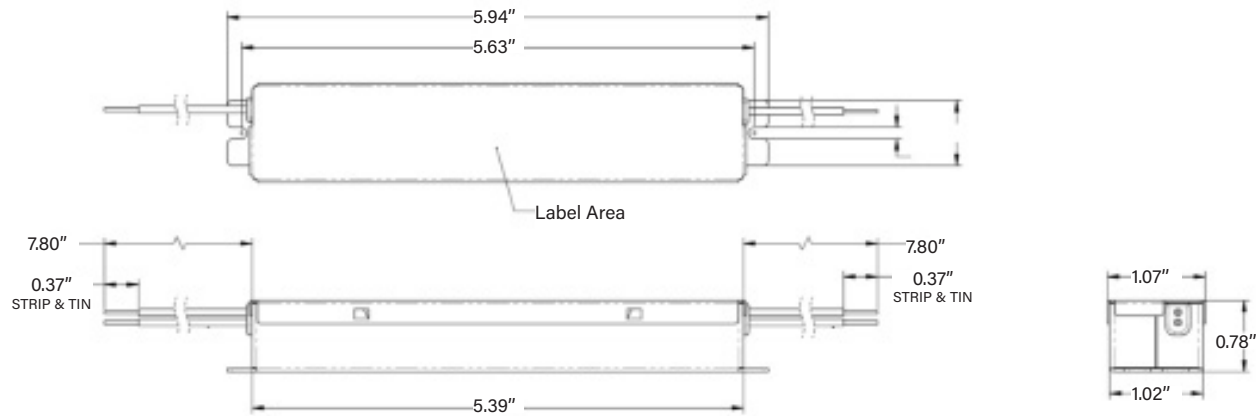

WIRING DIAGRAM

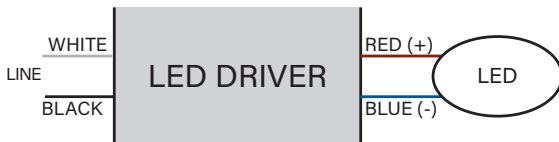

WIRING SPECIFICATIONS

INPUT	203mm, Stranded and Tinned 9.5mm, 18AWG, 105°C, 300V
OUTPUT	203mm, Stranded and Tinned 9.5mm, 18AWG, 105°C, 300V

ORDERING INFORMATION

ORDER CODE	PACKAGING STYLE	PACK QTY.	ITEM STATUS
KTLD-100-UV-24V-MC2-CP	Carton Pack	100 ea.	Quick Ship

CATALOG NUMBER BREAKDOWN

KTLD-100-UV-24V-MC2-CP

1

2

3

4

5

6

- 1 Keystone Technologies LED Driver
- 2 Max. Output Wattage
- 3 120-277V Input
- 4 Output Voltage
- 5 Case Style
- 6 Packaging Style