

The Advance Xitanium SR LED driver can help reduce complexity and cost of light fixtures used in wireless connected lighting systems in roadway lighting. It features a standard digital interface to enable direct connection to SR-certified components. Functionality that ordinarily would require additional auxiliary components is integrated into the driver. The result is a simple, cost-effective light fixture that can enable every fixture to become a wireless node.

Specifications

Input Voltage (Vrms)	Output Power (W)	Output Voltage (V)	Output Current (A)	Efficiency@ Max. Load and 70°C Case	Max. Case Temp. (°C)	Input Current (Arms)	Max. Input Power (W) ¹	Inrush Current (Apk/10%-µs)	THD @ Max. Load	Power Factor @ Max. Load	Surge Protection Common/Diff (KV)	Weight (Lbs/ kgs)	Envir. Protection Rating	Dim.	Dimming Range	Min. Output Current (A)	Driver Type
120	95	20-54 Class 2 Output	0.10-2.75	88	Life - 85°C UL - 90°C	0.90	118	54 / 280	<10%	>0.95	6/6	2.1 lbs / 0.95 KGS	UL damp & dry	DALI	5% - 100%	0.030	Constant Current
277				90		0.39		133 / 270									

Enclosure

	In. (mm)
Case Length	8.31 (211.1)
Case Width	2.31 (58.6)
Case Height	1.48 (37.6)
Mounting Length	8.91 (226.3)
Overall Length	9.47 (240.5)

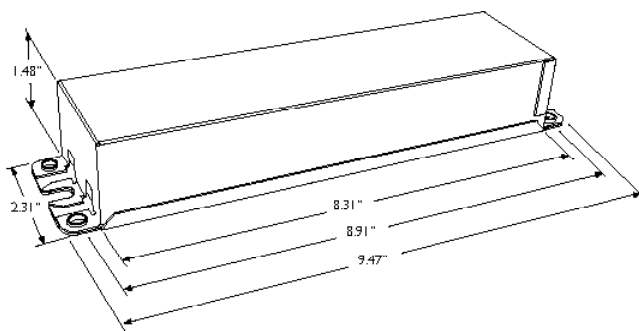

Wiring Diagram

Dimming	Wire Length (mm)
Black (Line)	270 (± 30)
White (Neutral)	270 (± 30)
Red (Positive, LED Output)	270 (± 30)
Blue (Negative, LED output)	270 (± 30)
Violet (Positive, 0-10V)	270 (± 30)
Pink (Negative, 0-10V)	270 (± 30)

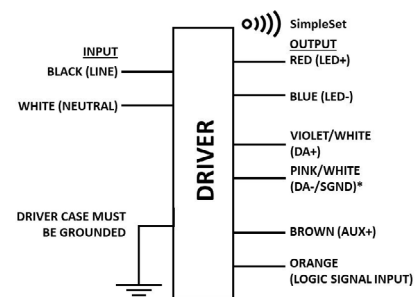

WARNING:

Install in accordance with national and local electrical codes. The field-wiring leads or push-in terminals shall be fully enclosed.

1. Based on 1W load from SR power supply and 6.2W load from auxiliary power supply.



Xitanium SR XI095C275V054VSF1

95W 120-277V 2.75A SR with Auxiliary Supply

Electrical Specifications

All the specifications are typical and at 25°C Tcase unless specified otherwise.

Features

- Compatible with SR-certified devices
- Standard SR digital interface including integral power supply
- Auxiliary power supply for higher power device requirements
- Accurate energy metering
- Logic signal input
- Drive current setting via SimpleSet
- 5-year limited warranty¹

Benefits

- Enables interoperability with multiple sensor/network system vendors
- Reduces cost and complexity of outdoor connected lighting systems²
- Eliminates need for high-voltage relays to increase system reliability
- 2% metering accuracy meets proposed ANSI standard C136.52
- Can be used with standard motion sensors for local control to complement network control

Application

- Area
- Industrial high-bay
- Parking garages
- Floodlights

Product Data

Ordering Information	
Order Code	XI095C275V054VSF1
Full Product Code	XI095C275V054VSF1 (Mid-pack, 10pcs/box)
Full Product Name	XITANIUM 95W 120-277V 2.75A SR with auxiliary supply
Global Trade Identification Number (GTIN)	781087151426
Input Information	
Inrush Current	Per NEMA 410
Line Voltage (AC operation)	120-277VAC +/- 10%
Line Current	0.90A @ 120V, 0.39A @ 277V
Line Frequency	50/60Hz
Surge Protection	Refer to table
Output Information	
Output Voltage Range	20VDC to 54VDC
Output Current Range	0.10A to 2.75A
Output Current Ripple	<15% at max. Iout (ripple = pk-avg/avg) Low frequency (<120 Hz) content <1%
Output Current Tolerance	±5% at max. output current
Open Circuit Voltage	54VDC
Protections	Short Circuit and Open Circuit Protection for LED + and LED-
Control Lead Current Leakage (SR, LSI)	0.01mA, recommended max number of control circuits in parallel refer to Design-In Guide
Features	
AOC (adjustable output current)	0.10A to 2.75A via SimpleSet programming (refer to graphs and notes)
Life	50,000 hr nom. @ TC 85°C; 100,000 hr nom. @ TC 75°C (refer to graphs)
Suitable for Outdoor Use?	Yes
Interfaces	SimpleSet, SR, Logic Signal Input (LSI), Auxiliary Power Supply

1. Advance Xitanium LED drivers are designed and manufactured to engineering standards correlating to an average life expectancy of 50,000 hours of operation at maximum rated case temperature. Minimum 90% survivals based on MTBF modeling.

2. Functionality that ordinarily would require additional auxiliary components is integrated into the driver.

Xitanium SR XI095C275V054VSF1

95W 120-277V 2.75A SR with Auxiliary Supply

Electrical Specifications

All the specifications are typical and at 25°C Tcase unless specified otherwise.

Product Data (continued)

Min. Ambient Temp	-40°C
Max. Case Temperature (Tcase)	Life - 85°C; UL - 90°C
Input Over-voltage	Can survive input over-voltage stress of 320VAC for 48 hours and 350VAC for 2 hours
Earth Leakage Current	0.75 mA [max.]
THD Total	Refer to graph
Power Factor	Refer to graph
Efficiency	Refer to graph
Power Reporting Accuracy	± 2% in performance window and under nominal operating conditions
SR Interface	
Digital Protocol	Specifications available to SR-Certified Partners
SR Power Supply	Specifications available to SR-Certified Partners
Auxiliary Power Supply	
Power	3W continuous, 10.5W peak for 1.2ms
Voltage	24V+/-10%
Ripple	300mV peak-peak for resistive load
Protection	Overload and short circuit protected
Last Gasp Energy	200mJ typ.
Logic Signal Input (LSI)	
Dry Contact Input	Yes
Logic Low	<3V or open
Logic High	>7V
Max. Current Draw	2mA
Environment & Approbation	
Agency Approbations	UL8750, UL1310, UL935, NOM, cUL
Audible Noise	<24dB Class A
Isolation Between Output and Input	Refer to table
Isolation of Controls	Refer to table
EMC (electromagnetic compliance)	Meets FCC 47 Part 15 Class A
Envir. Protection Rating	UL Dry & Damp
Net Weight Per Piece	2.1 lbs / 0.95 kgs

Xitanium SR XI095C275V054VSF1

95W 120-277V 2.75A SR with Auxiliary Supply

Electrical Specifications

All specifications are typical and at 25°C Tcase unless specified otherwise.

Logic Signal Input (LSI) Characteristics (Typical)

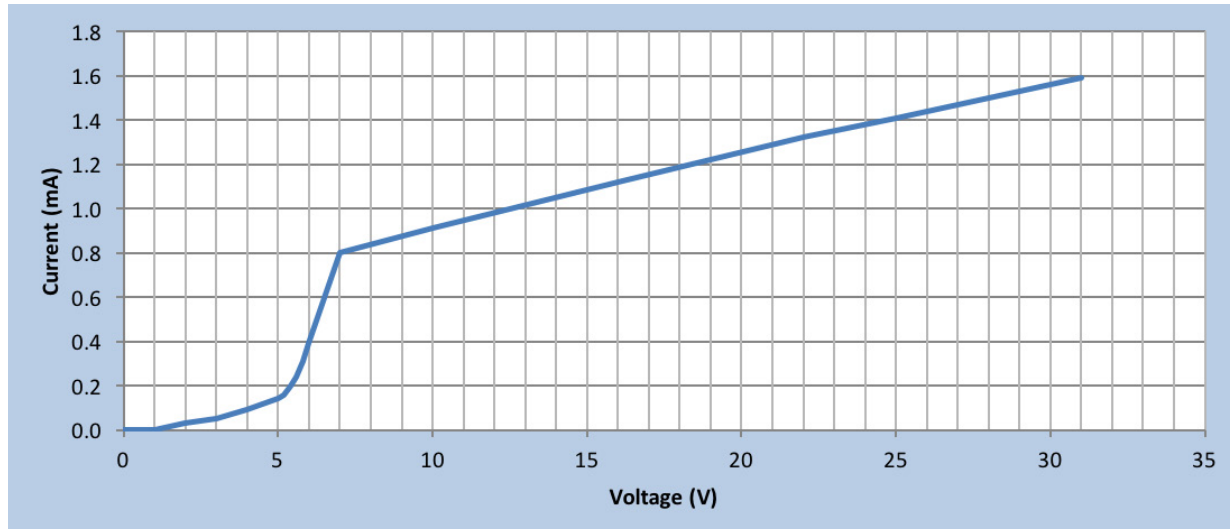

Xitanium SR XI095C275V054VSF1

95W 120-277V 2.75A SR with Auxiliary Supply

Electrical Specifications

All specifications are typical and at 25°C Tcase unless specified otherwise.

Operating Window

The driver current cutback feature provides for an increased output voltage with a reduced output current during abnormal LED operation, such as cold weather starting. Output tolerance +/-5%.

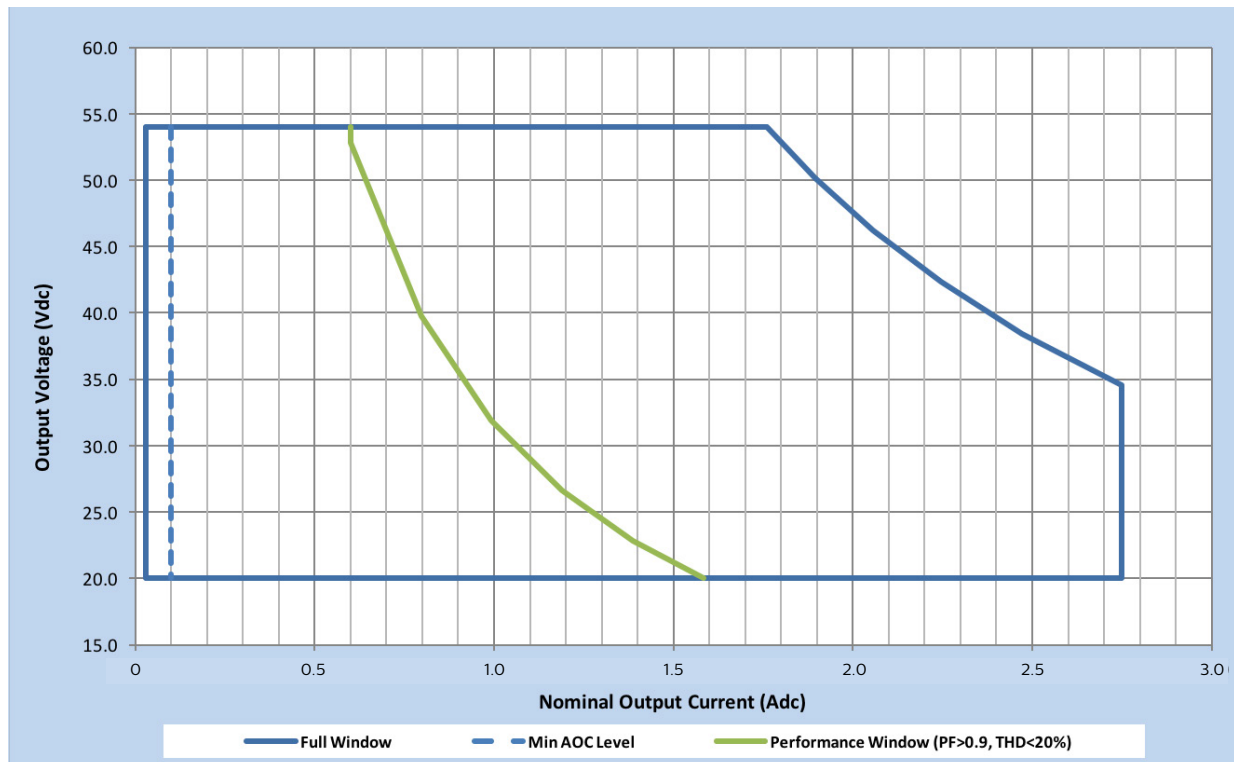

Xitanium SR XI095C275V054VSF1

95W 120-277V 2.75A SR with Auxiliary Supply

Electrical Specifications

All specifications are typical and at 25°C Tcase unless specified otherwise.

Dimming Characteristics

SR drivers use a logarithmic dimming curve as default. Dimming is accomplished through the 2-wire DALI connection to the sensor. DALI standard IEC62386_102 Edition 2 defines the logarithmic dimming curve. DALI standard IEC62386_101 Edition 2 defines the linear dimming curve as well as the command for switching between logarithmic and linear curves.

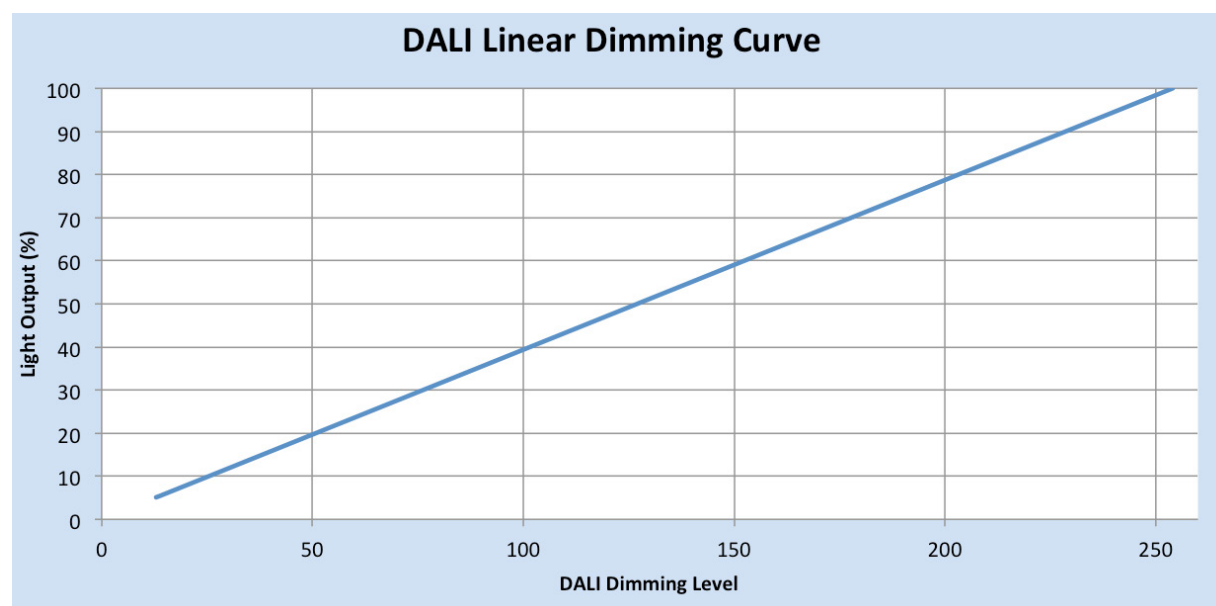
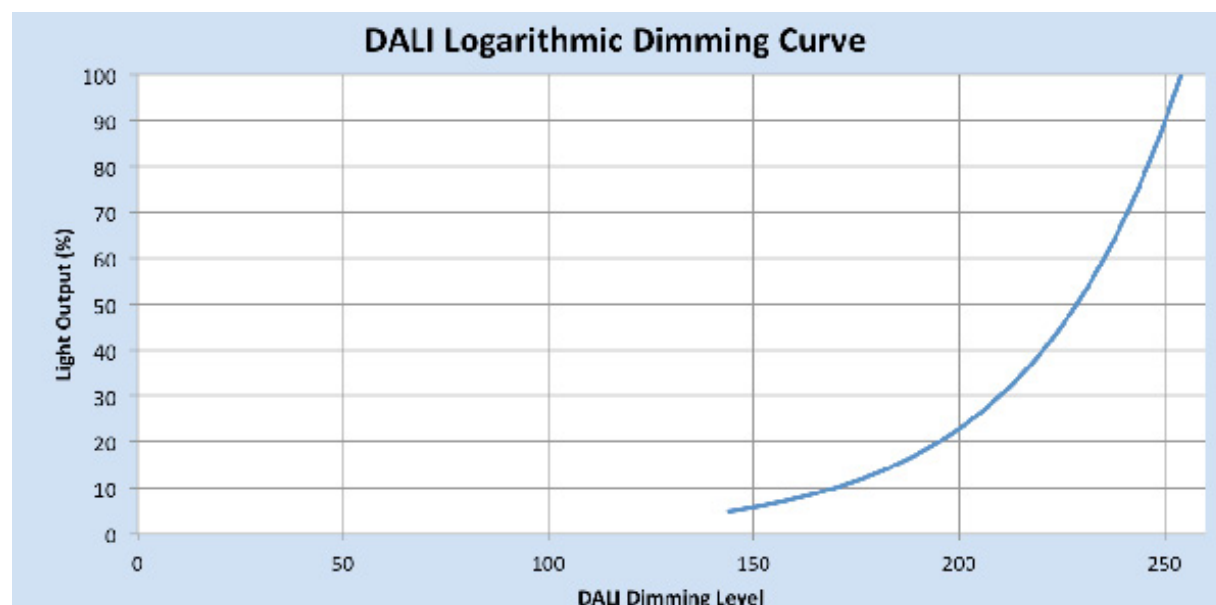

Xitanium SR XI095C275V054VSF1

95W 120-277V 2.75A SR with Auxiliary Supply

Performance Characteristics

Based on measurements on a typical sample. The accuracy of the measurements is within the tolerance of the measurement instruments. The graphs are meant to be a guideline and not a specification. Data below at 70°C Tcase.

Efficiency Vs. Output Voltage @ 120VAC

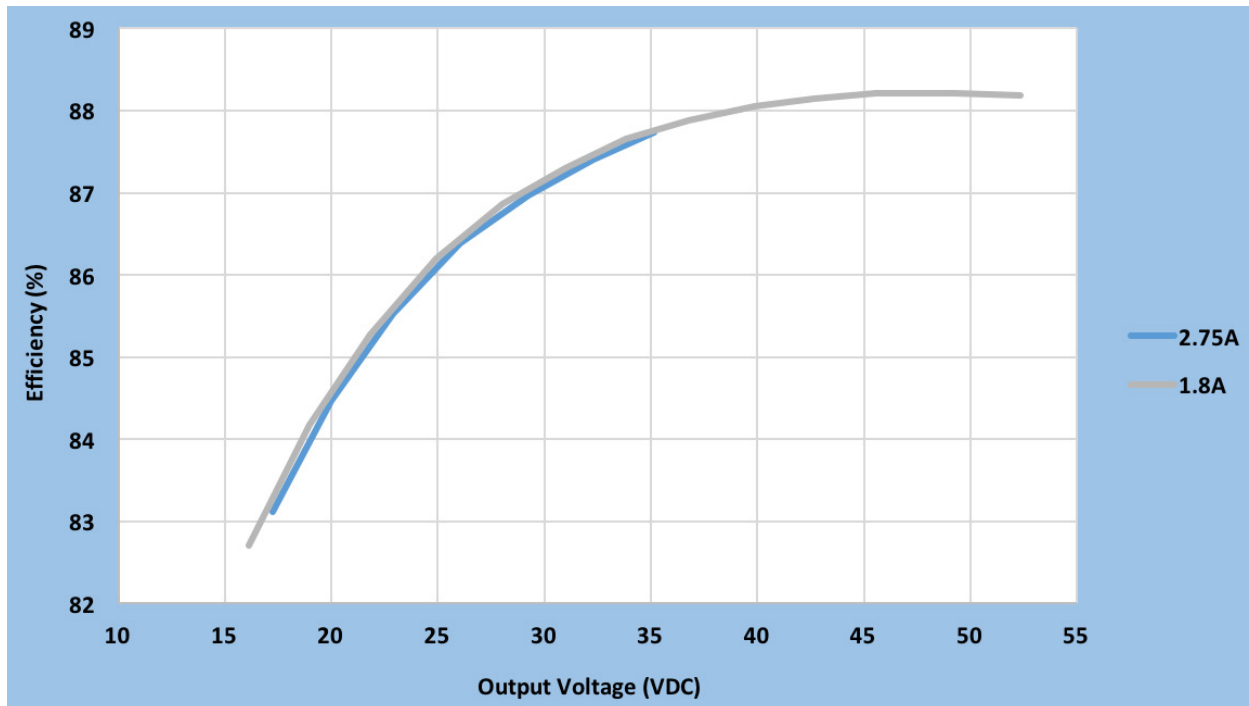

Efficiency Vs. Output Voltage @ 277VAC

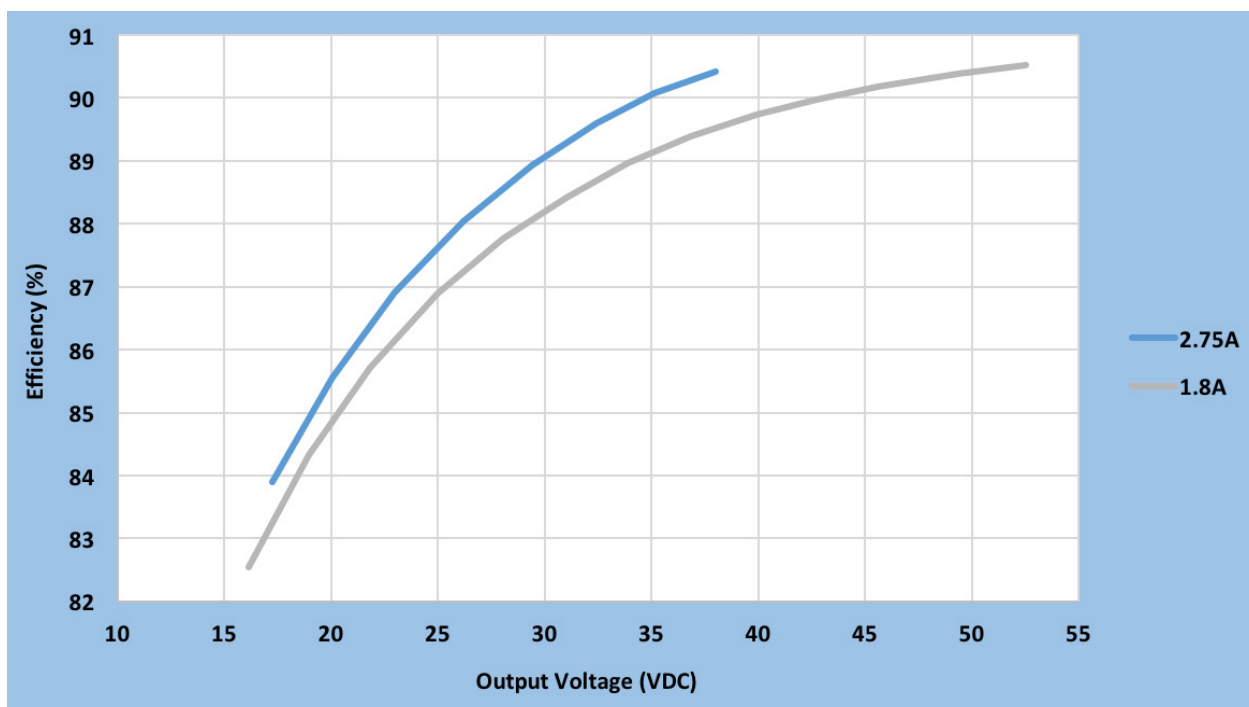

Xitanium SR XI095C275V054VSF1

95W 120-277V 2.75A SR with Auxiliary Supply

Performance Characteristics

Based on measurements on a typical sample. The accuracy of the measurements is within the tolerance of the measurement instruments. The graphs are meant to be a guideline and not a specification. Data below at 70°C Tcase.

Power Factor Vs. Output Power

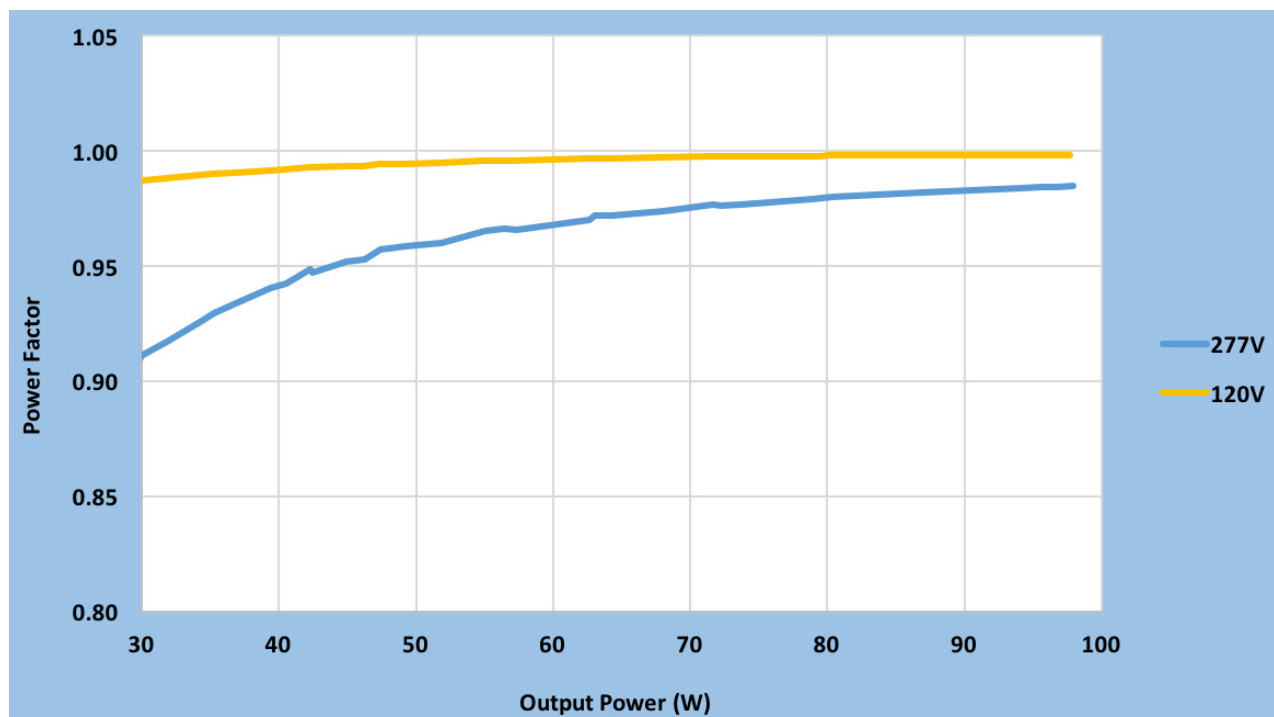

Total Harmonic Distortion Vs. Output Power

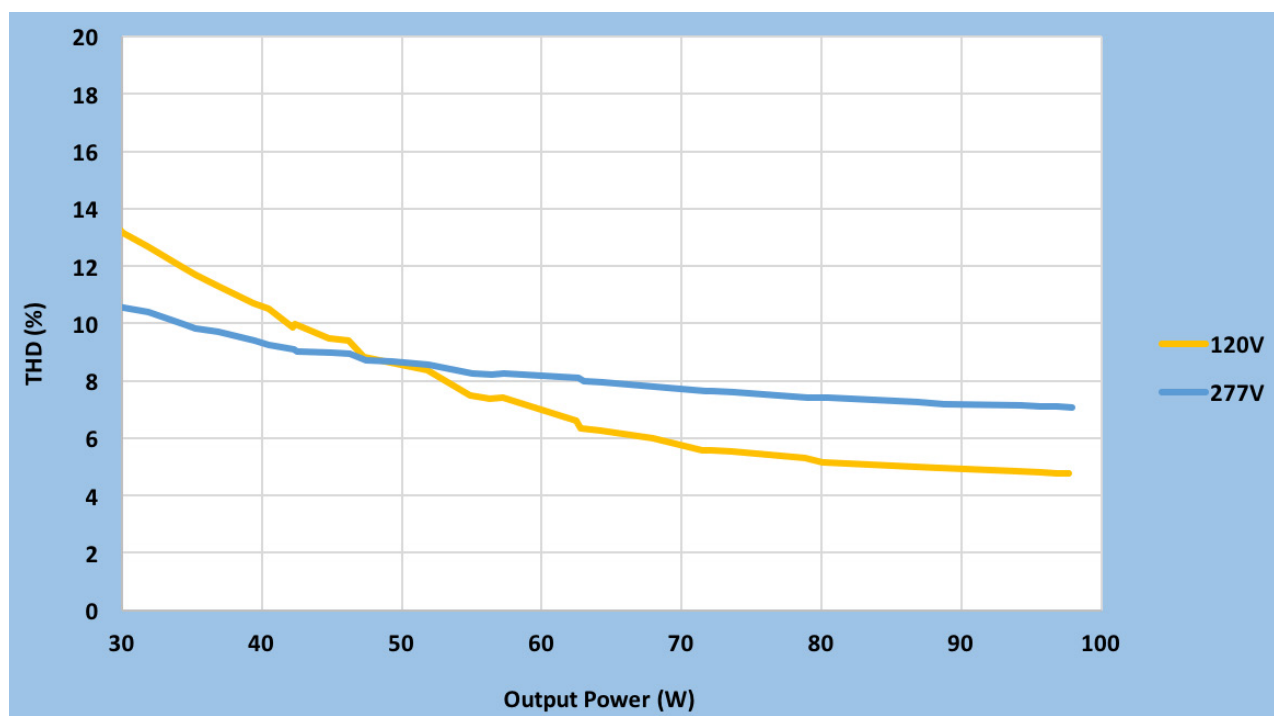

Xitanium SR XI095C275V054VSF1

95W 120-277V 2.75A SR with Auxiliary Supply

Electrical Specifications

All the specifications are typical and at 25°C Tcase unless specified otherwise.

Output Current Vs. Driver Case Temperature

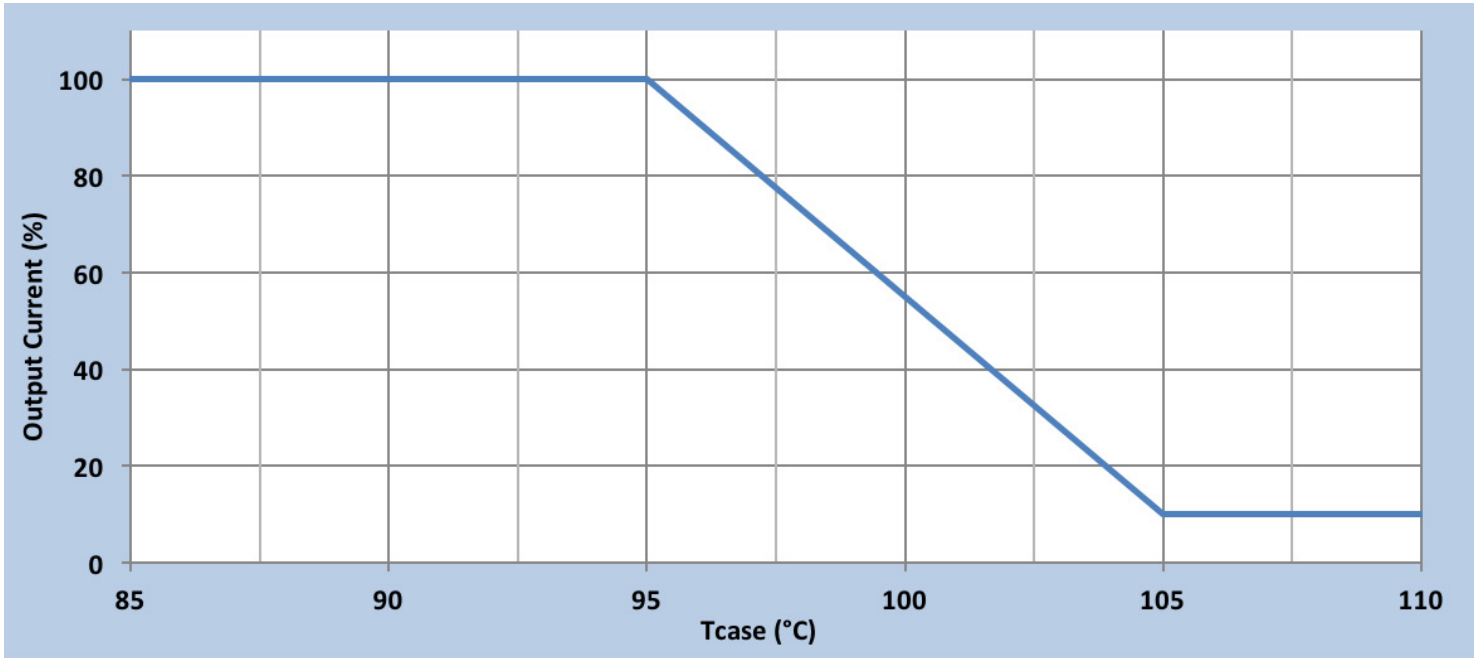

Driver Lifetime Vs. Driver Case Temperature

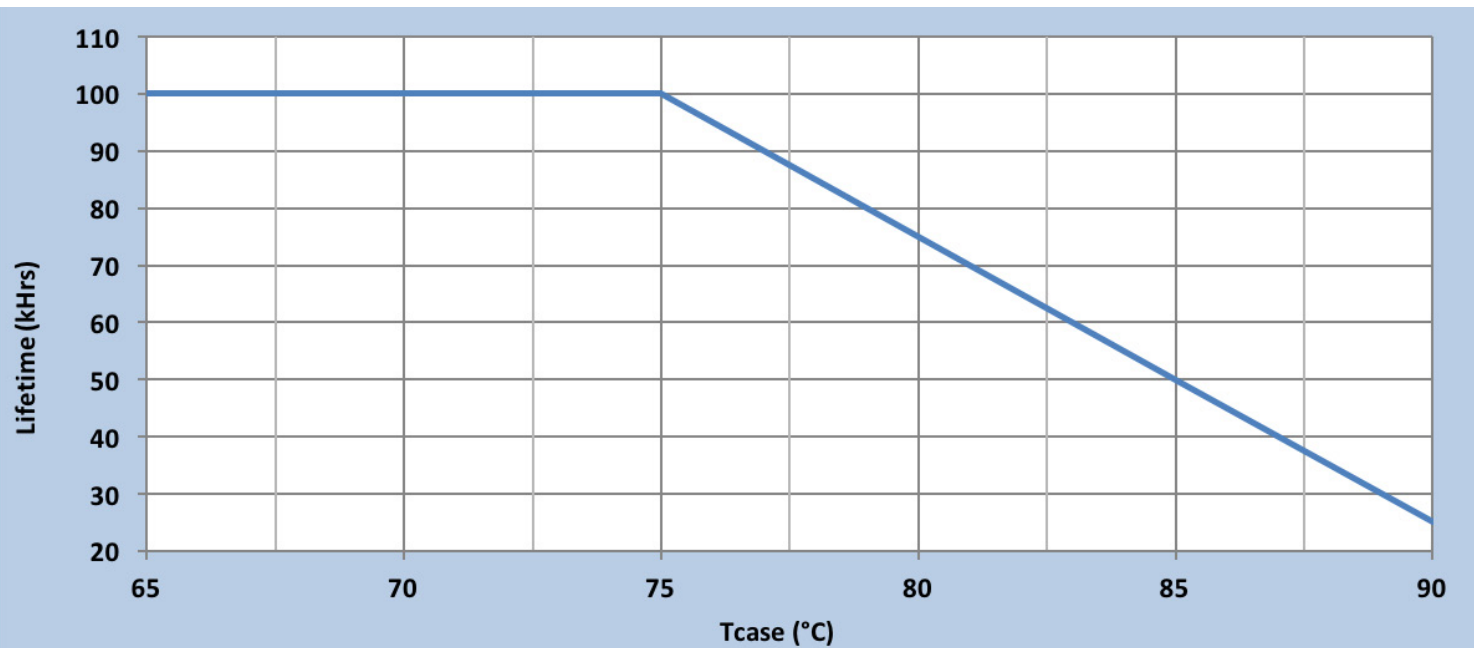

Xitanium SR XI095C275V054VSF1

95W 120-277V 2.75A SR with Auxiliary Supply

Inrush Current Info

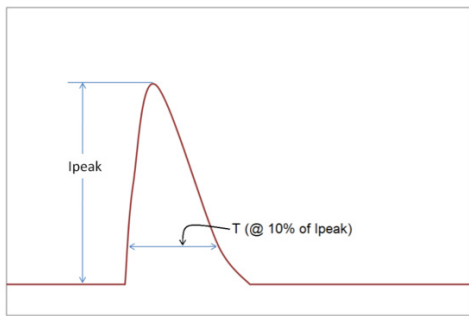

V_{in}	I_{peak}	T (@ 10% of I_{peak})
120 Vac	54A	280 μ s
277 Vac	133A	270 μ s

Inrush current is measured at peak of the corresponding line voltage, source impedance per NEMA 410.

Lightning Surge Info

ANSI Surge Type	Differential Mode (L-N)	Common Mode (L-G, N-G, L&N-G)
1.2/50 μ s Combination Wave (w/t 2 ₂)	6kV	6kV

Isolation

Isolation	Input Leads	Output Leads	SR Leads (SR+, SR-/SGND, AUX, and LSI), Class 2 Only	Enclosure
Input Leads	NA	2xU+1kV	2xU+1kV	2xU+1kV
Output Leads	2xU+1kV	NA	500Vrms	500Vrms
SR Leads (SR+, SR-/SGND, AUX, and LSI), Class 2 only	2xU+1kV	500Vrms	NA	500Vrms
Enclosure	2xU+1kV	500Vrms	500Vrms	NA

U = Max. input voltage

