



The Advance Xitanium Sensor Ready (SR) LED driver can help reduce complexity and cost of light fixtures used in connected lighting systems in outdoor lighting applications. It's D4i certified and features a standard compliant digital interface to enable direct connection to compatible networked lighting control (NLC) solutions. Functionality that ordinarily would require additional auxiliary components is integrated into the driver. The result is a simple, cost-effective light fixture that can enable every fixture to become a wireless node

Specifications

Input Voltage (Vrms)	Output Power (W)	Output Voltage (V)	Output Current (A)	Efficiency@ Max. Load and 70°C Case	Max. Case Temp. (°C)	Input Current (Arms)	Max. Input Power (W) ¹	THD @ Max. Load	Power Factor @ Max. Load	Surge Protection Common/Diff (KV)	Dim	Dimming Range	Min Output current
120	75	43-118	0.07-0.70	89	80	0.74	88	<10%	>0.95	6/6	DALI	10%-100%	0.07A
277				92		0.32							

Enclosure

	In. (mm)	Tolerance
Overall Length (A1)	6.59 (167.5)	±0.5
Mounting Hole Distance (A2)	6.03 (153.2)	±0.5
Case Length (A3)	5.43 (138.0)	±0.5
Case Width (B1)	2.31 (58.8)	±0.5
Mounting Hole Distance (B2)	1.69 (42.9)	±0.5
Case Height (C1)	1.48 (37.6)	±1.0
Mounting Hole Diameter (D1)	0.31 (7.9)	±0.5
Mounting Hole Diameter (D2)	0.24 (6.2)	±0.5
Center of SimpleSet Antenna (G1)	2.30 (58.5)	±3.0

Wiring Diagram

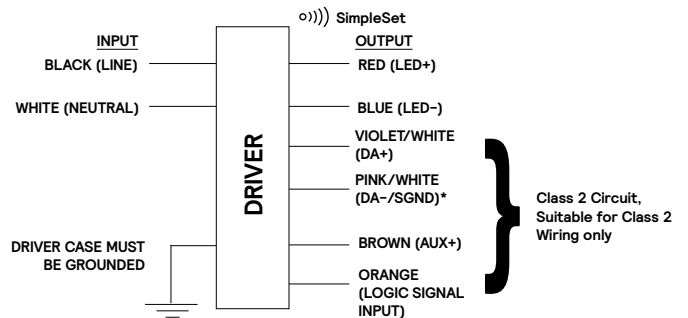

*DA-/SGND will change from GREY/WHITE to PINK/WHITE or PINK from 2021 onwards.

*DA-/SGND is the common return for DA+, AUX+ and Logical Signal Input

WARNING:
Install in accordance with national and local electrical codes.

	Wire length (mm)
Black (Line)	270 (± 30)
White (Neutral)	270 (± 30)
Red (Positive, LED output)	270 (± 30)
Blue (Negative, LED output)	270 (± 30)
Violet/White (DA+)	270 (± 30)
Grey/White (DA-/SGND)	270 (± 30)
Brown (AUX+)	270 (± 30)
Orange (LSI)	270 (± 30)

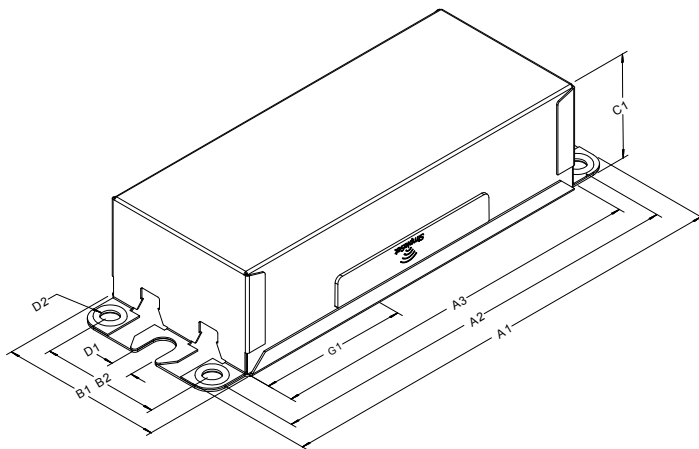

1. Based on 3W loading on auxiliary power supply.

Xitanium SR XI075C070V118VSY3

75W 120-277V 0.7A SR

Electrical Specifications

All the specifications are typical and at 25°C Tcase unless specified otherwise.

Features

- Compatible with SR-certified devices
- Standard-compliant (ANSI C137.4 and DiiA) digital interface including:
 - Integrated DALI bus power supply (Part 250)
 - Memory Bank 1 extension
 - Energy Monitoring and Diagnostics (Parts 251, 252, 253)
 - 24V Auxiliary power supply for higher power device requirements (Part 150)
- Accurate energy metering

- Logic signal input
- Drive current setting via SimpleSet
- 5-year limited warranty¹

Benefits

- Enables interoperability with compatible networked lighting control solutions (NLCS) from multiple third-party.
- Reduces cost and complexity of outdoor connected lighting systems².
- Standardized luminaire data for Asset Management.

- 2% metering accuracy meets proposed ANSI standard C136.52.
- Can be used with standard motion sensors for local control to complement network control.

Application

- Area
- Roadway
- Parking garages
- Floodlights

Product Data

Ordering Information	
Order Code	XI075C070V118VSY3 (Mid-Pack, 12pcs/Box), 12NC: 929002729813
GTIN	781087167380
Input Information	
Min Mains Voltage Operational	108Vac
Max Mains Voltage Operational	305Vac
Line Frequency	50/60Hz
Output Information	
Flicker	Meets NEMA77
Leakage Current of Control Circuit (SR, Aux and LSI)	0.05mA, recommended max number of control circuits in parallel refer to Design-In Guide
Output Current Ripple= pk-avg/avg	<15% at max. Iout
Output Current Tolerance	±5% at max. output current
Maximum Open Circuit Voltage	180VDC
Protections	Short Circuit and Open Circuit Protection for LED + and LED- Thermal foldback protection
Features	
AOC (adjustable output current)	0.07A to 0.7A via SimpleSet programming (refer to graphs and notes)
Suitable for Outdoor Use	Yes
Interfaces	Simpleset, Sensor Ready(SR), Logical Signal Input (LSI), Auxiliary Power Supply
Power Reporting Accuracy	+/-2% in performance window and under nominal operating conditions
Configurable Features	Advance Driver Thermal Limit, Dynadimmer, Password protection, and many others.
Auxiliary Power Supply (According to ANSI C137.4)	
Nominal Aux. Output Voltage	24Vdc
Rated Aux. Output Power	3W continuous, 6W peak
Protections	Short Circuit & Open Circuit Protection for Aux. + and DA-

1. Advance Xitanium LED drivers are designed and manufactured to engineering standards correlating to an average life expectancy of 50,000 hours of operation at maximum rated case temperature. Minimum 90% survivals based on MTBF modeling.

Xitanium SR XI075C070V118VSY3

75W 120-277V 0.7A SR

Electrical Specifications

All specifications are typical and at 25°C Tcase unless specified otherwise.

Product Data (continued)

SR power supply	
Current Source	52mA to 60mA
Voltage Range	12V to 20V
Communication Protocol	DALI-2, D4i, ANSI C137.4
Mis-wiring to Mains Protection	No
Logic Signal Input (LSI)	
Dry Contact Input	Yes
Logic Low	<3V or open
Logic High	>7V
Max. Current Draw	2mA
Environment & Approbation	
Operating Ambient Temp. Range	-40°C to +55°C
Max Case Temperature (Tcase)	80°C for Life & 80°C for UL Safety
Agency Approbations	UL 8750, CSA-CC22.2 No. 250.13, NOM, cUL, Class P (UL, cUL, ETL)
Electromagnetic Compliance	FCC Title 47 Part 15 Class A
Audible Noise	<24dB Class A
Weight	1.58Lbs/ 0.68Kgs
Envir. Protection Rating	UL Dry and Damp

Xitanium SR XI075C070V118VSY3

75W 120-277V 0.7A SR

Electrical Specifications

All specifications are typical and at 25°C Tcase unless specified otherwise.

Logic Signal Input (LSI) Characteristics (Typical)

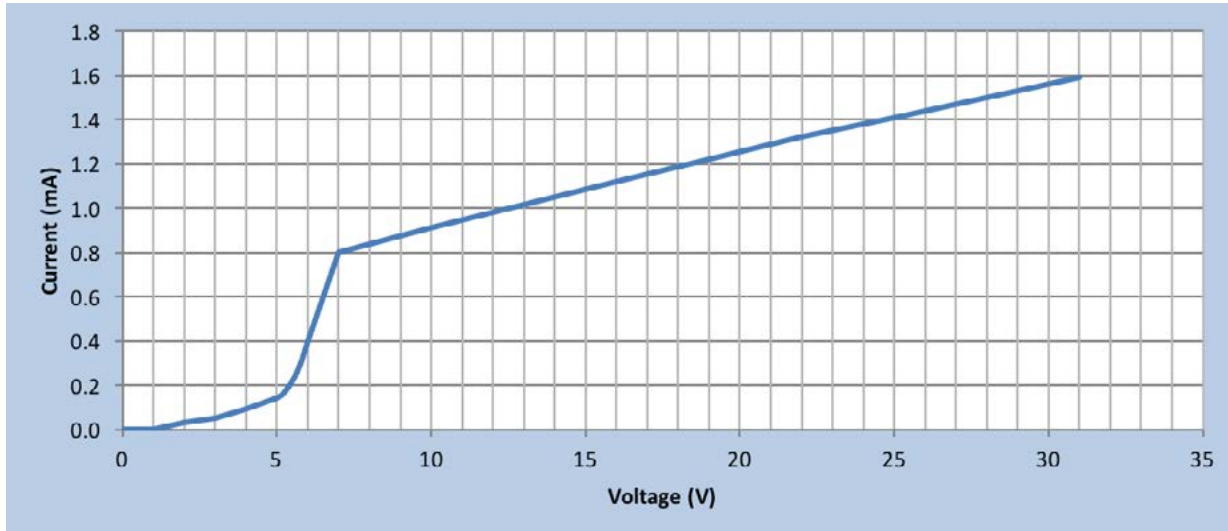

Xitanium SR XI075C070V118VSY3

75W 120-277V 0.7A SR

Electrical Specifications

All specifications are typical and at 25°C Tcase unless specified otherwise.

Operating Window

The driver current cutback feature provides for an increased output voltage with a reduced output current during abnormal LED operation, such as cold weather starting.

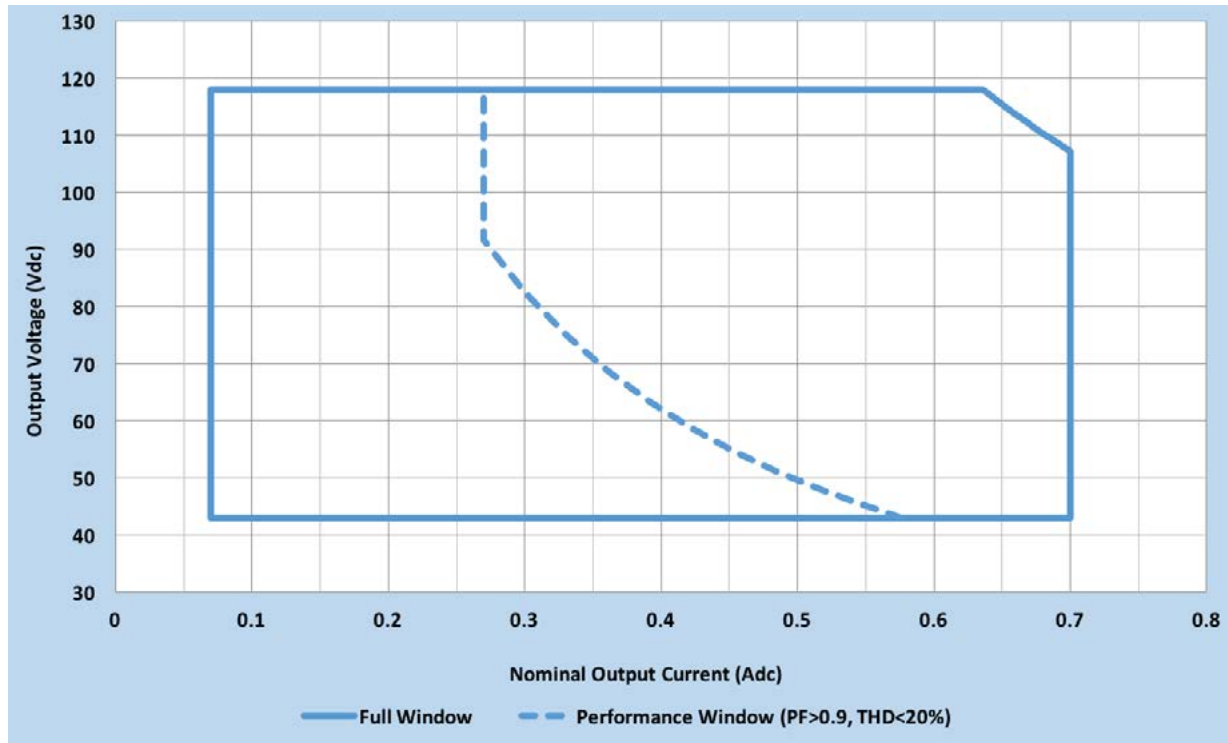

Xitanium SR XI075C070V118VSY3

75W 120-277V 0.7A SR

Electrical Specifications

All specifications are typical and at 25°C Tcase unless specified otherwise.

Dimming Characteristics

SR drivers use a logarithmic dimming curve as default. Dimming is accomplished through the 2-wire DALI connection to the sensor. DALI standard IEC62386_102 Edition 2 defines the logarithmic dimming curve. DALI standard IEC62386_101 Edition 2 defines the linear dimming curve as well as the command for switching between logarithmic and linear curves.

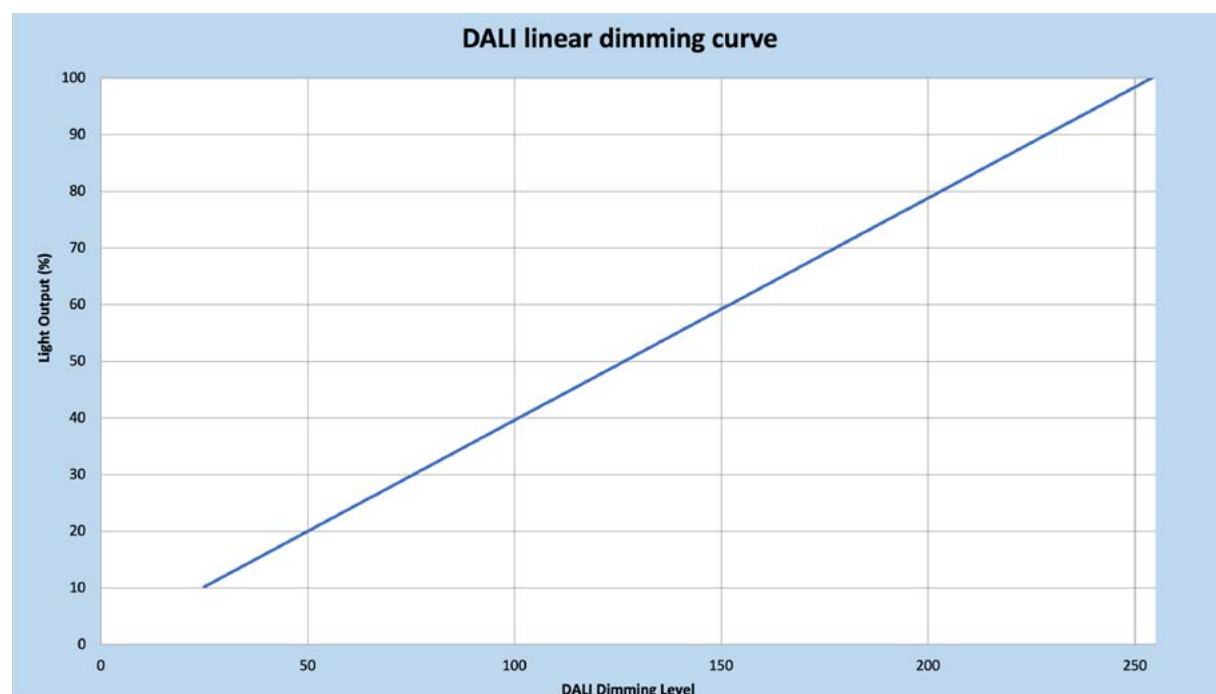
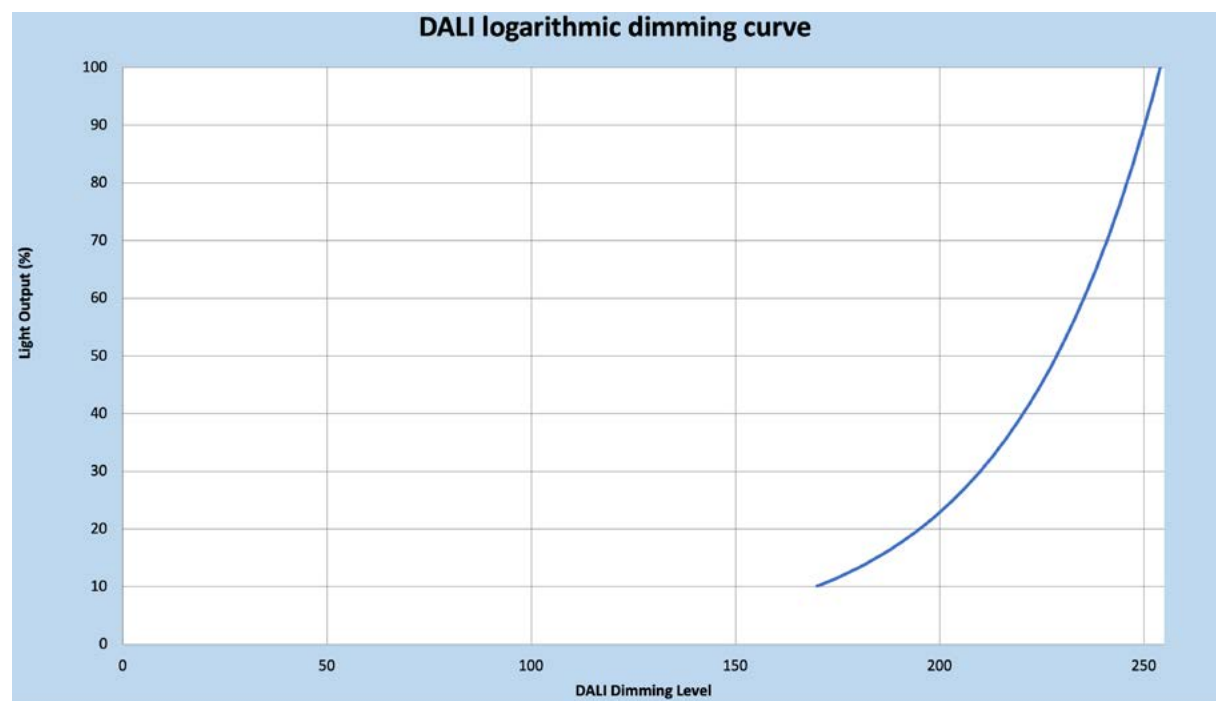

Xitanium SR XI075C070V118VSY3

75W 120-277V 0.7A SR

Performance Characteristics

Based on measurements on a typical sample. The accuracy of the measurements is within the tolerance of the measurement instruments. The graphs are meant to be a guideline and not a specification. Data below at 70°C Tcase.

Efficiency Vs. Output Voltage @ 120VAC

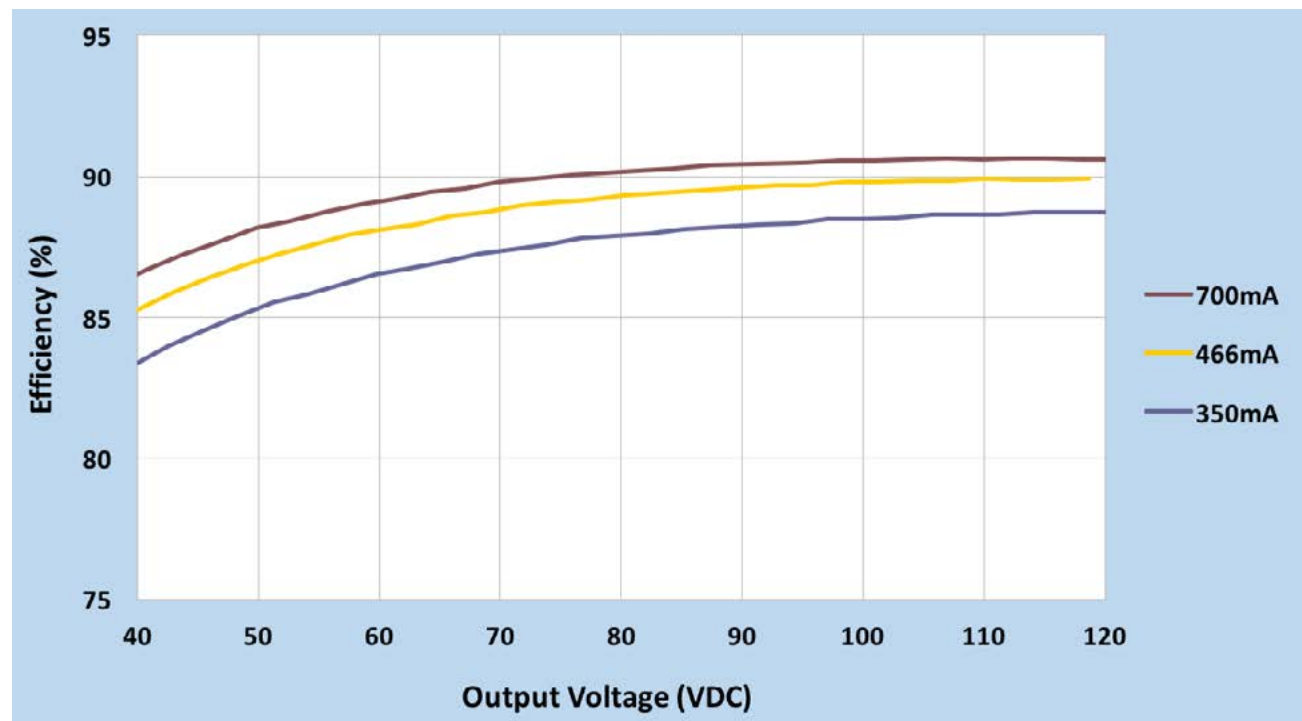

Efficiency Vs. Output Voltage @ 277VAC

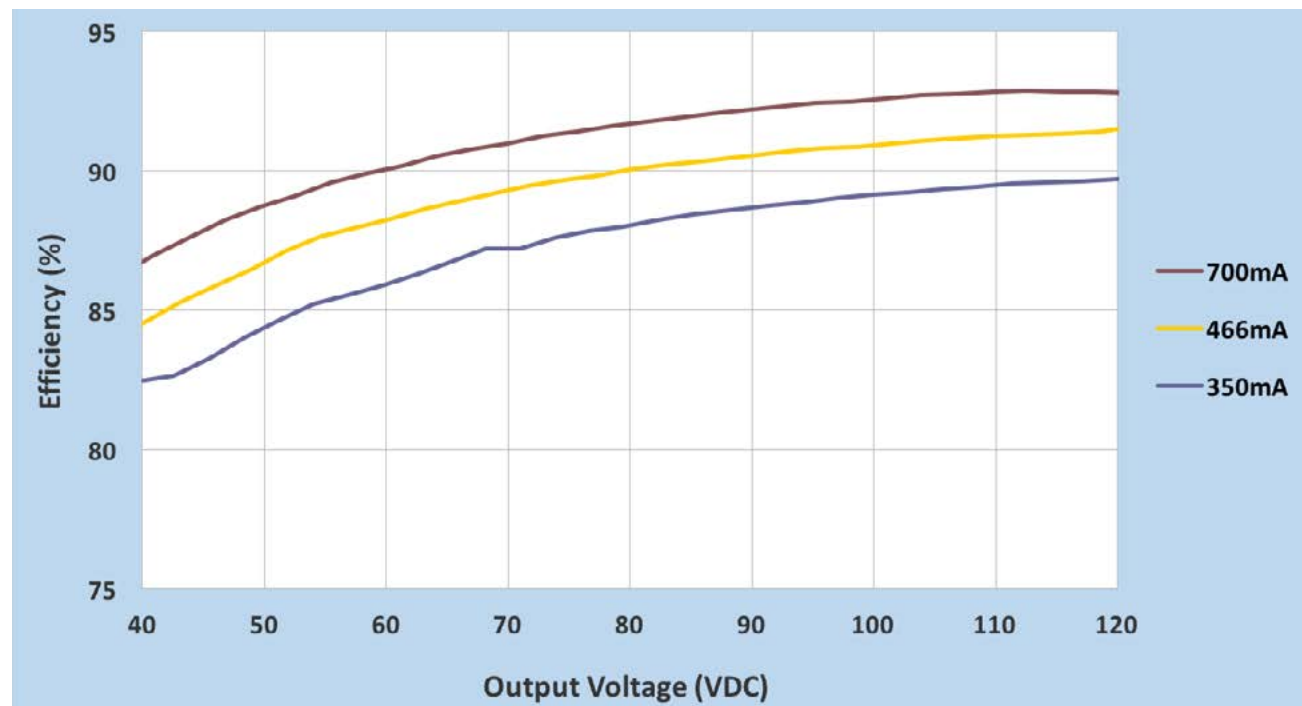

Xitanium SR XI075C070V118VSY3

75W 120-277V 0.7A SR

Performance Characteristics

Based on measurements on a typical sample. The accuracy of the measurements is within the tolerance of the measurement instruments. The graphs are meant to be a guideline and not a specification. Data below at 70°C Tcase.

Power Factor Vs. Output Power

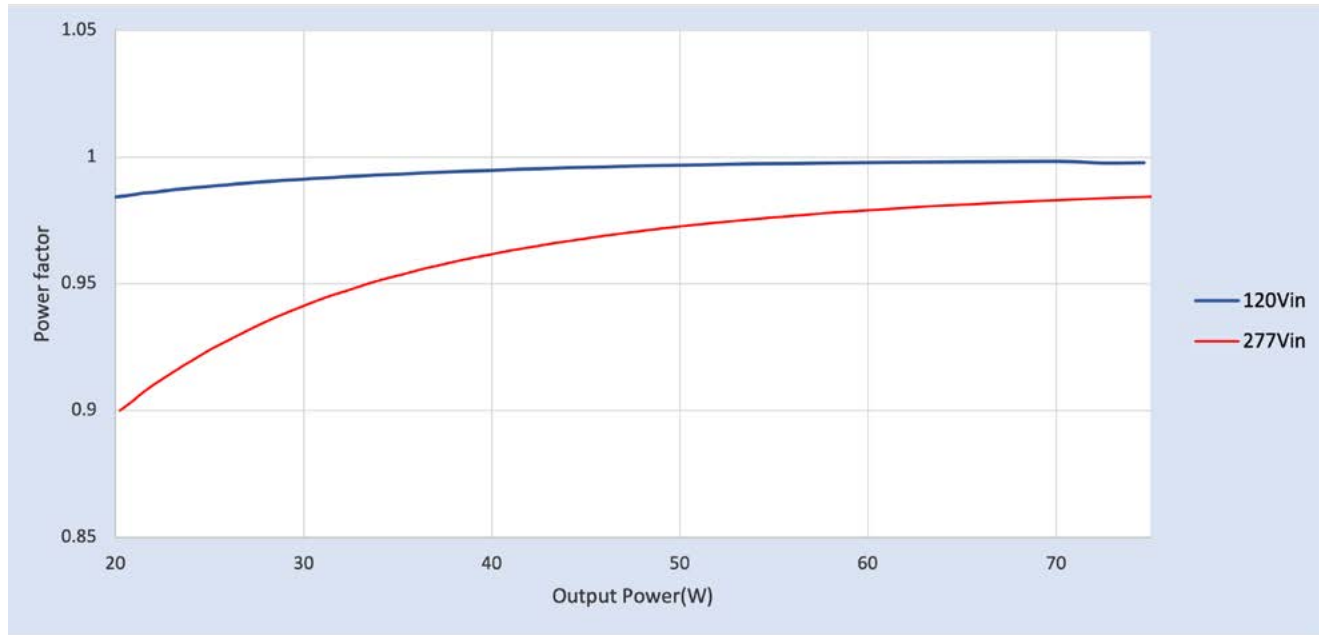

Total Harmonic Distortion Vs. Output Power

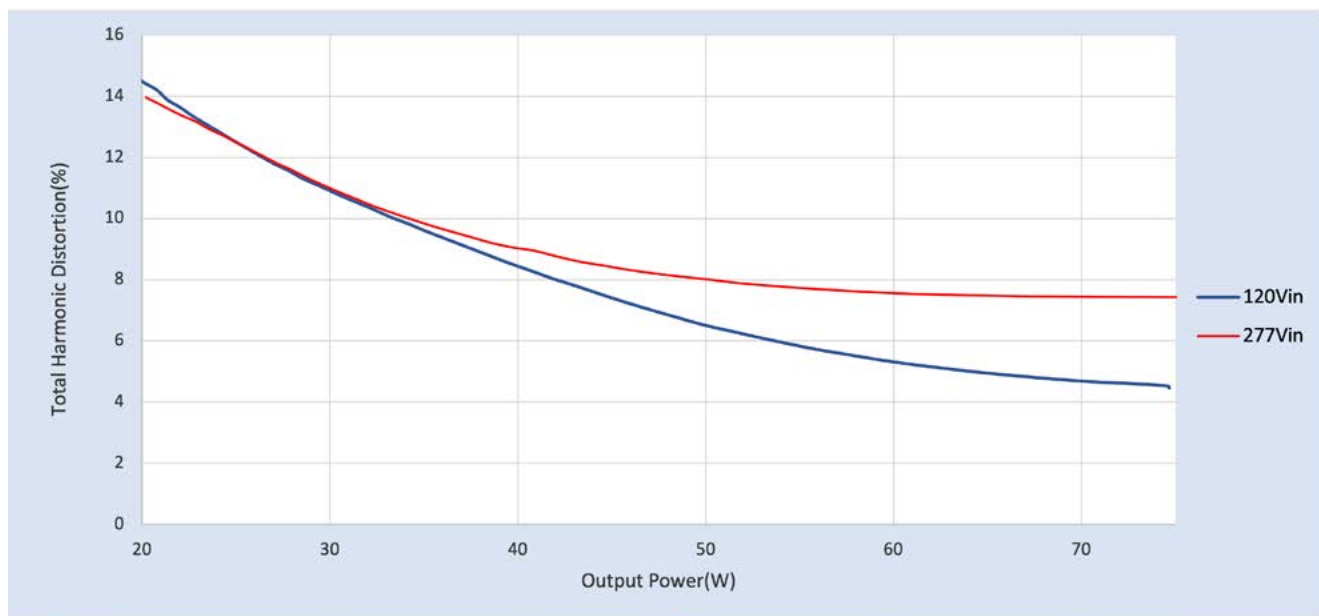

Xitanium SR XI075C070V118VSY3

75W 120-277V 0.7A SR

Electrical Specifications

All specifications are typical and at 25°C Tcase unless specified otherwise.

Driver Lifetime Vs. Driver Case Temperature

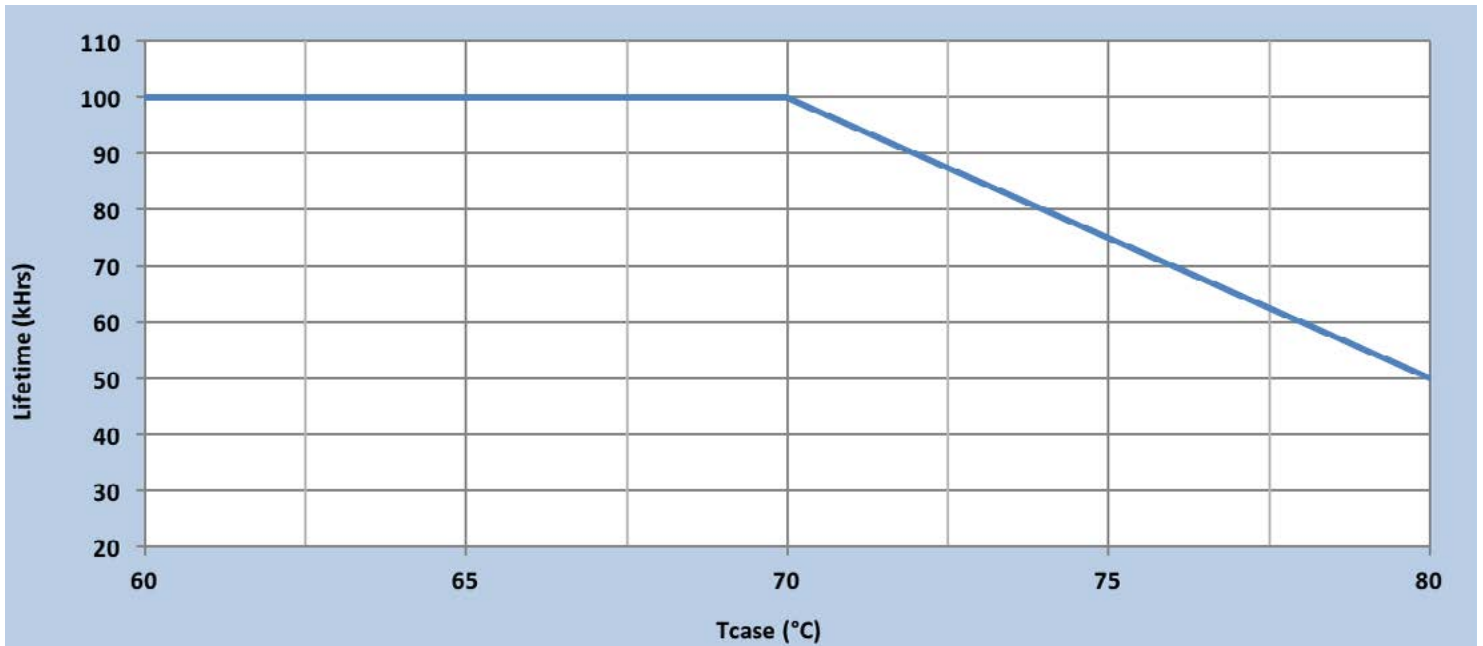

Xitanium SR XI075C070V118VSY3

75W 120-277V 0.7A SR

Inrush Current Info

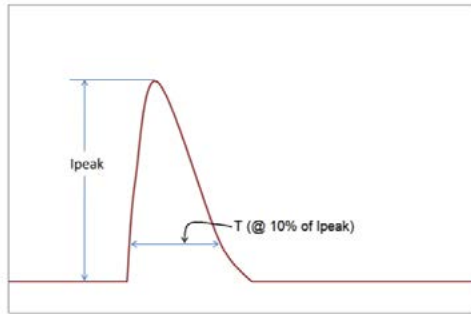

V_{in}	I_{peak}	T (@ 10% of I_{peak})
120 Vac	41A	202 μ s
277 Vac	96A	192 μ s

Inrush current is measured at peak of the corresponding line voltage, source impedance per NEMA 410.

Lightning Surge Info

ANSI Surge Type	Differential Mode (L-N)	Common Mode (L-G, N-G, L&N-G)
1.2/50 μ s Combination Wave (w/t 2 ₂)	6kV	6kV

Isolation

Isolation	Input Leads	Output Leads	(DA+, DA-/SGND, Aux and LSI), Class 2 Only	Enclosure
Input Leads	NA	2xU+1kV	2xU+1kV	2xU+1kV
Output Leads	2xU+1kV	NA	2xU+1kV	2xU+1kV
(DA+, DA-/SGND, Aux and LSI), Class 2 Only	2xU+1kV	2xU+1kV	NA	500V
Enclosure	2xU+1kV	2xU+1kV	500V	NA

U = Max. working voltage



© 2021 Signify Holding. All rights reserved. The information provided herein is subject to change, without notice. Signify does not give any representation or warranty as to the accuracy or completeness of the information included herein and shall not be liable for any action in reliance thereon. The information presented in this document is not intended as any commercial offer and does not form part of any quotation or contract, unless otherwise agreed by Signify.

Signify North America Corporation
200 Franklin Square Drive,
Somerset, NJ 08873
Telephone 855-486-2216

Signify Canada Ltd.
281 Hillmount Road,
Markham, ON, Canada L6C 2S3
Telephone 800-668-9008

All trademarks are owned by Signify Holding or their respective owners.