



SENSORWORX®

LOW VOLTAGE CEILING MOUNT SENSORS

INSTALLATION & OPERATION INSTRUCTIONS

(Units w/ Date Code 231012 and later)

MODELS

MODEL #	PIR	ACOUSTIC	PHOTOCELL	LENS TYPE
SWX-201-1	•			SMALL MOTION
SWX-211-1	•		•	SMALL MOTION
SWX-221-1	•	•		SMALL MOTION
SWX-231-1	•	•	•	SMALL MOTION
SWX-202-1	•			LARGE MOTION
SWX-212-1	•		•	LARGE MOTION
SWX-222-1	•	•		LARGE MOTION
SWX-232-1	•	•	•	LARGE MOTION
SWX-203-1	•			HIGH BAY
SWX-213-1	•		•	HIGH BAY

ADDITIONAL UNIT OPTIONS

- **D**: Daylight Harvesting
- **AR**: Isolated Auxiliary Relay
- **HE**: High Humidity Environment
- **BK**: Black Cover & Lens

ACCESSORIES

SWX-299-JP:
Ceiling Sensor Trim Ring for Mounting to Single Gang Mudring, Handy Box, or 4" Octagon Box

SPECIFICATIONS

ELECTRICAL

OPERATING VOLTAGE

12-24 VAC/VDC

CURRENT DRAW

5mA (PIR models)
7mA (PIR w/ Photozell models)
10mA (Dual Tech. models)
12mA (Dual Tech. w/ Photozell models)

OUTPUT

Logic High VDC (Occupied Mode)

RECOMMENDED POWER PACK

SWX-900 Series (SENSORWORX)

DIMMING CAPACITY (-D OPTION)

50mA

DIMMING COMPATIBILITY

0-10 VDC Ballasts or Drivers
Compliant with IEC 60929 Annex E.2

ISOLATED RELAY RATING (-AR)

1A @ 30 VDC/ VAC

CODE COMPLIANCE

Sensors can be used to meet ASHRAE 90.1, IECC, & Title 24 energy code requirements

ENVIRONMENTAL

OPERATING TEMP

32°F to 122°F (0°C to 50°C) -
Standard
-40° F/C (with **-HE** Option)

RELATIVE HUMIDITY

0-95% Non-Condensing,
Indoor Use Only

PHYSICAL

SIZE & WEIGHT

4.00" Diameter x 1.25" H
(10.16 x 3.17 cm)
4.75 oz

COLOR

White or Black

OPERATION

TIME DELAYS

30 sec to 30 min (Typical)
10 Minute Default
5 sec Time Delay Test Mode
(Expires After 10 min)



FEATURES

- **Digital Passive Infrared (PIR) Detection**
- **Passive Acoustic Detection (Optional)**
- **360° Coverage Pattern**
- **Compact Size and Matte Finish**
- **Four Contractor Friendly Mounting Methods**
- **Mounting Nipple Attachment with Integrated Hole Saw**
- **Convenient Test Mode and Adjustable Time Delays**

OVERVIEW

SENSORWORX sensors detect movement in the infrared energy that radiates from occupants as they move within the device's field-of-view. Once occupancy is identified, the sensor signals a power/relay pack to switch on the connected lighting. If equipped with passive dual technology (PIR/Acoustic), the unit's microphone is then enabled to further enhance detection while the lights are on. This overlapping passive acoustic occupancy detection is important for rooms with obstructions or where occupant motion will be limited. An internal timer is set to keep lights on during brief periods of inactivity, and is reset every time occupancy is signaled by either the passive infrared or acoustic detection technologies. Additionally, units equipped with ambient daylight detection (photocells) or daylight harvesting are capable of overriding lights off and/or dimming during periods of occupancy.

SENSOR PLACEMENT

Typically, a sensor should be located such that all entrances to the room/space are adequately covered. Ideally, a sensor should be located so that its coverage beams are perpendicular to the door. This ensures that an occupant is detected immediately upon entering. See Diagram 1. Note, however, it is important to locate a sensor such that its coverage pattern can not extend through an open door, which could result in detection of persons walking by, but not into, a room.

If line of sight between a sensor and occupants is blocked (for example by a cubicle wall or stall), dual technology sensors should be alternatively utilized or additional PIR sensors should be added until line of sight is restored. Dual technology is recommended for all spaces where occupants are sitting or where motion within the space is limited (private offices, open offices, restrooms with stalls, libraries). Dual technology is not recommended for hallways or warehouses.

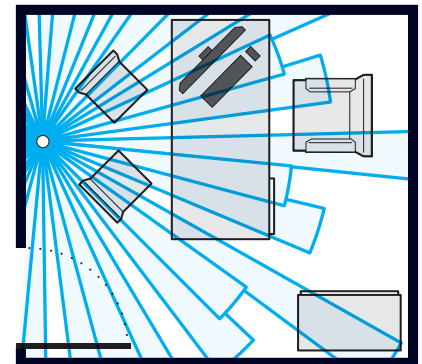

Diagram 1 - Recommended Sensor Placement in a Private Office

COVERAGE

PASSIVE INFRARED (PIR)

- 8 to 15 ft (2.44 to 4.57 m) mounting height recommended for small and large motion lenses. For 15 to 40 ft (2.44 to 12.20 m) mounting heights use high bay lens.
- Detection range improves when walking across beams as compared to into beams.
- Lenses can be swapped in field if necessary, contact technical support for assistance.

DUAL TECHNOLOGY (PIR/ACOUSTIC)

- Units with dual technology (SWX-221-1 and SWX-222-1) have overlapping acoustic detection of the complete PIR coverage area.
- A PIR event is required to initially enable acoustic detection.
- Sounds indicating occupancy reset the sensor's time delay while non-occupant noises are filtered out.
- Occupant sounds alone will not keep lights on indefinitely, PIR motion must be periodically detected for lights to remain on for an extended time.
- After sensor time out expires, acoustic detection remains enabled for 15 seconds to enable voice reactivation of lights for additional convenience and safety.

SMALL MOTION 360°

- Best choice for detection of small motions from sitting occupants (e.g., hand motion)
- ~500 ft² of coverage

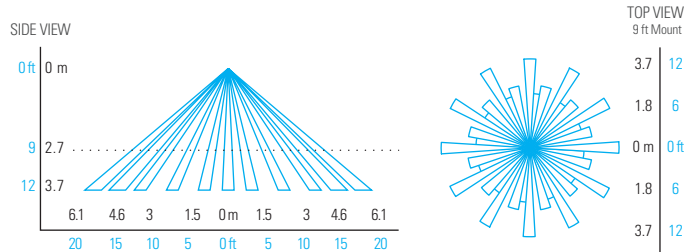

LARGE MOTION 360°

- Best choice for detection of larger motion (e.g., walking).
- ~2000 ft² of coverage.
- One of the longer segments of the coverage pattern aligns with the screw hole axis on the sensor (shown as dotted line on Top View diagram below).

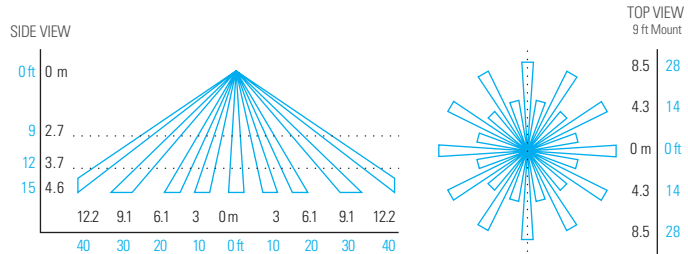

HIGH BAY 360°

- Best choice for mounting heights above 15ft.
- Recommended for gyms, warehouses, and other high ceiling areas where multiple sensor coverage is required.
- Not recommended for areas where occupants are sitting.
- Gaps between outer segments get larger as mounting height increases.
- Not available with acoustic (dual technology).

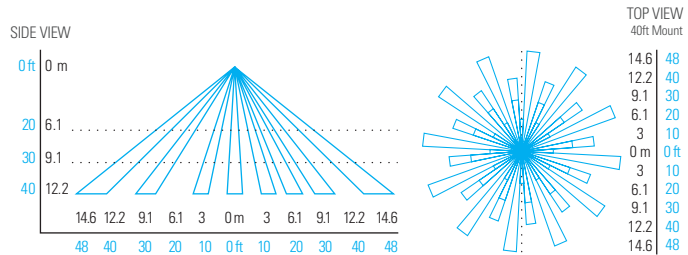

WIRING

- Apply power to connected power packs only after low voltage sensor connections have been made.
- Wiring sensors to a live power pack is not recommended, although in cases where required, it is recommended that the red wire be connected last.

STANDARD WIRING

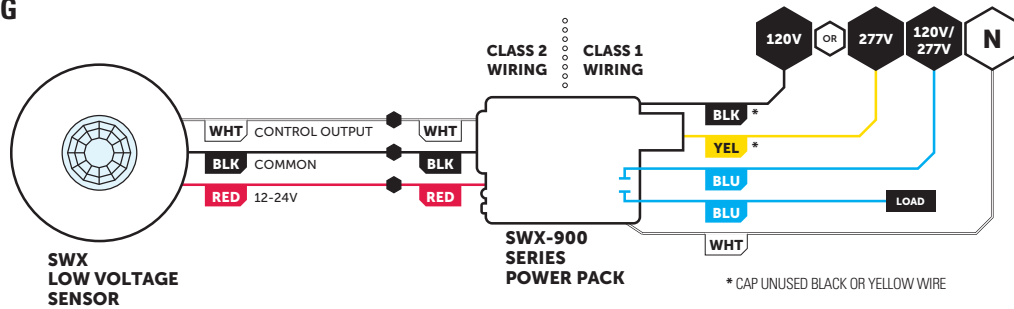

MULTIPLE SENSOR WIRING

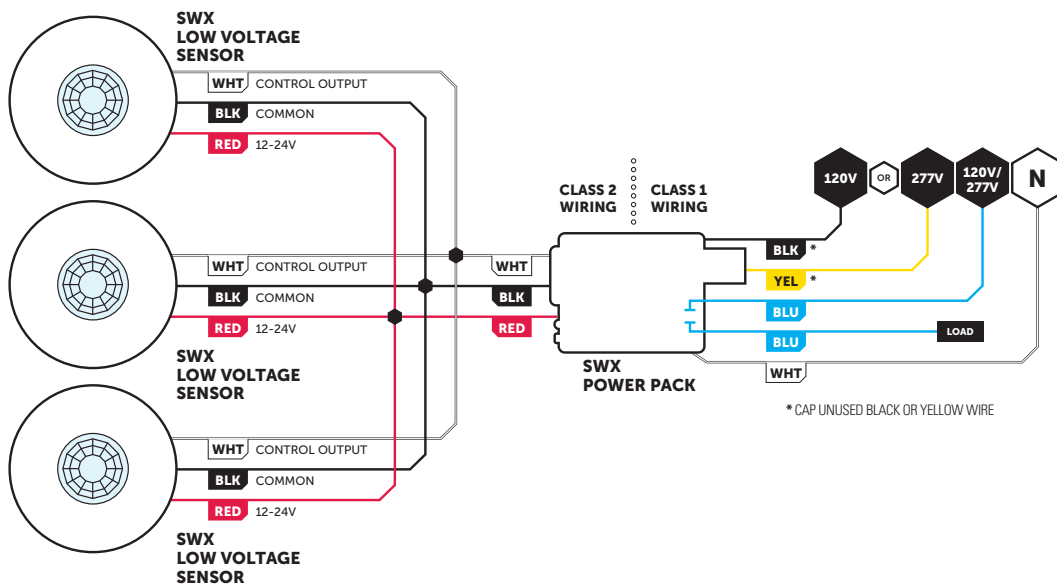

SEPARATE OCCUPANCY ZONE & OCCUPANCY + ON/OFF PHOTOCELL ZONE

- During occupied state, photocell output (blue wire) will turn lights off if ambient light level surpasses threshold and back on if level drops.
- Also configurable to prevent lights from initially turning on, but not to turn them off once lights are on.

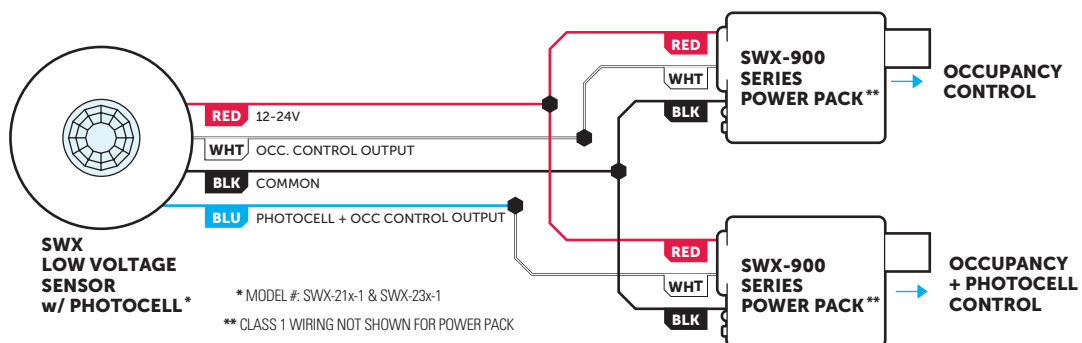

WIRING CONT.

SENSOR w/ AUXILIARY RELAY OUPUT (-AR OPTION)

- The auxiliary output relay (model option -AR) is designed to interface with many types of building management systems (i.e. BMS), VAV units, and relay panels.
- Operation of relay (brown wires) is configurable:
 - By default the relay latches closed when occupancy is detected (white wire goes high).
 - Relay can be configured to alternatively follow the occupancy + photocell (blue wire) output.
 - Relay polarity (open vs closed) can also be reversed.

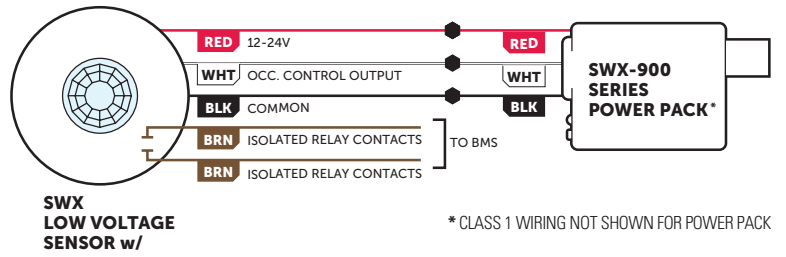

OCCUPANCY + DAYLIGHT HARVESTING

- Lights will gradually dim in order to maximize energy savings while maintaining desired overall lighting level.
- Lights will dim only to low trim if white wire is connected to power pack. Connect blue wire to power pack to go completely off from daylight.

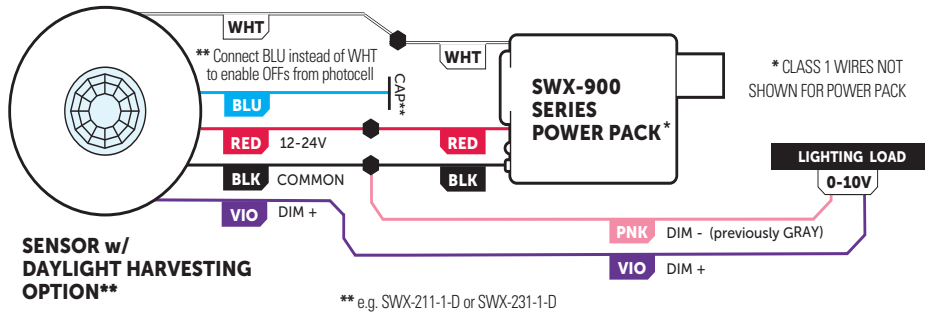

OCCUPANCY + DAYLIGHT HARVESTING + AUXILIARY RELAY (-AR) OUTPUT

- Lights will gradually dim in order to maximize energy savings while maintaining desired overall lighting level.
- Lights will dim only to low trim if white wire is connected to power pack. Connect blue wire to power pack to go completely off from daylight.
- See operation detail options for auxiliary relay (brown wires) in previous auxiliary relay output wiring section.

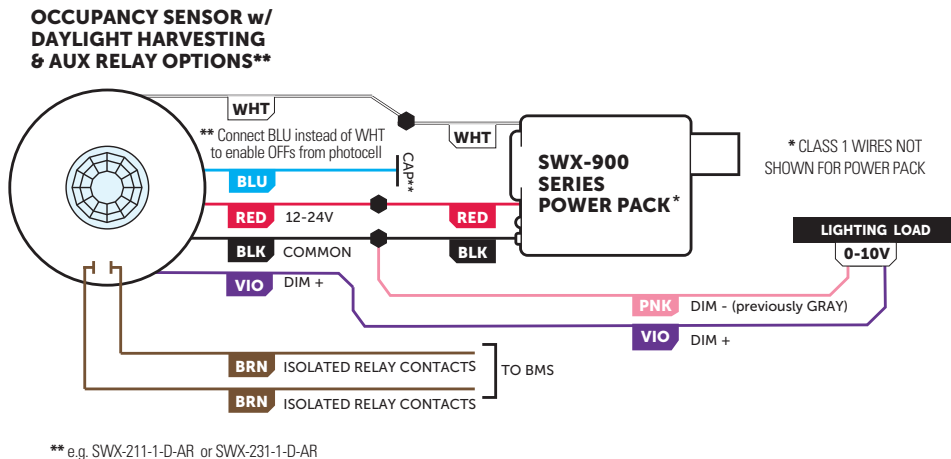

INSTALLATION INSTRUCTIONS

MOUNTING OPTIONS

- A. Chase nipple & lock nut (included) for mounting unit to ceiling tile or 1/2" knockout in junction box. See Side Diagram below.
- B. Screw holes for directly mounting to ceiling surface, 3-1/2" (trade size) octagon box, or mud ring with 2-3/4" spaced ears. See Front Diagram below.

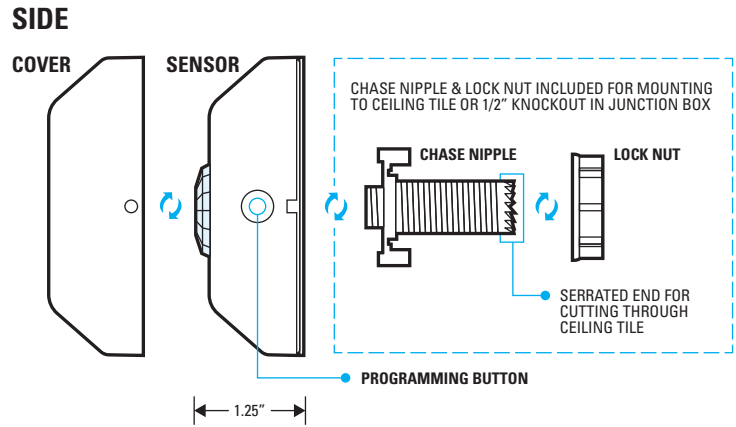
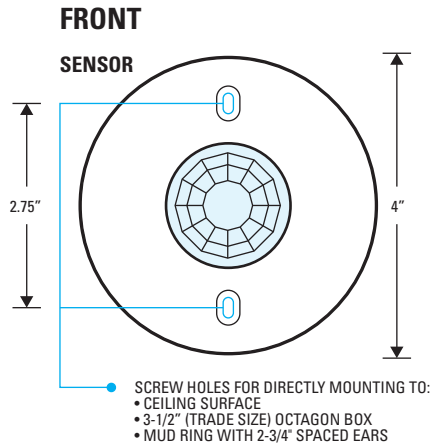

Note: If mounting to a Single Gang Mudring, Handy Box, or 4" Octagon Box, a trim ring is required. Part Number: **SWX-299-JP**.

TESTING & TROUBLESHOOTING

TEST MODE

An occupancy test mode with a 5 second time delay is provided in order to efficiently perform walk testing. The sensor will blink white on any detected PIR event and blue on any detected Acoustic event (if equipped), although its time delay will only be reset by a PIR event. In units equipped with a photocell, the test mode will only factor in occupancy. Ambient daylight conditions are ignored.

TO PUT A SENSOR IN TEST MODE FOR 10 MINUTES:

- Press sensor's pushbutton 2 times, then wait until LED starts blinking back current setting (approx 2 secs).
- Interrupt blinking and press button 1 time to start test mode. After 10 minutes, the sensor's time delay will revert to previous setting.

RESET

To restore factory settings, press and release the pushbutton 8 times, wait 2 seconds, then press and release the pushbutton 3 times again.

GENERAL CONFIGURATION SETTINGS

FUNCTION #2 - TIME DELAY CONFIGURATION

The length of time after the last occupancy event that the sensor will stay in the occupied state.

CHANGING TIME DELAY SETTINGS:

1. Read through the Time Delay Settings list on the right and note the number of the desired time delay setting (e.g., default is 4 = 10 minutes).
2. Press and release the unit's pushbutton twice, then wait 2 seconds. The white LED will blink back the number of the current setting.
3. At any time after blink back starts, enter number of new setting (from Time Delay Settings tables on right).
4. New setting is saved after white LED blinks new number back 3 times. If blue LED double flashes at any time, start process over.

FUNCTION #6 - MICROPHONE (ACOUSTIC DETECTION)

Dual technology sensors prevent non-occupant sounds from resetting the time delay by dynamically reducing the microphones sensitivity at specific frequencies. In some environments, decreasing the sensitivity across all frequencies so that lights go off sooner, may be preferred. A unit's microphone can also be disabled (effectively changing sensor to a PIR only version).

CHANGING MICROPHONE SETTINGS:

1. Press unit's pushbutton 6 times, then wait two seconds. The white LED will blink back the number of current setting (from table on right).
2. At any time after blink back starts, enter number of new setting by pressing the button equal times to choice from table.
3. New setting will be saved after white LED blinks back new number 3 times. If blue LED double flashes at any time, start process over.

FUNCTION #7 - LED INDICATION

By default, the sensor blinks its white LED whenever it detects PIR motion. A unit with dual technology will also blink the LED white when it acoustically detects occupancy. Alternatively, the LED can be enabled to blink white for only PIR events and blue for an acoustic event.

CHANGING LED INDICATION SETTINGS:

1. Press unit's pushbutton 7 times, then wait two seconds. The white LED will blink back the number of current setting (from table on right).
2. At any time after blink back starts, enter new setting by pressing the button equal times to numbered choices.
3. New setting will be saved after white LED blinks back new number 3 times. If blue LED double flashes at any time, start process over.

FUNCTION #14 - AUXILIARY RELAY OPERATION (-AR OPTION)

By default, the auxiliary relay provided on sensors with the -AR option will follow the state of the sensor's white occupancy output wire (i.e. when the white wire is high indicating occupancy, the auxiliary relay is closed).

CHANGING THE AUXILIARY RELAY OPERATION:

1. Press unit's pushbutton 14 times, then wait two seconds. The LED will blink back white the number of current setting (from table on right).
2. At any time after blink back starts, enter new setting by pressing the button equal times to numbered choices.
3. New setting will be saved after white LED blinks back new number 3 times. If blue LED double flashes at any time, start process over.

FUNCTION #2 - TIME DELAY SETTINGS

SETTING #	DESCRIPTION
1	Test Mode*
2	30 sec
3	5 min
4	10 min (default)
5	15 min
6	20 min
7	30 min

* 5 SEC TIME DELAY, EXPIRES AFTER 10 MIN

EXTENDED TIME DELAYS**

SETTING #	DESCRIPTION
8	1 hr
9	2 hr
10	4 hr
11	8 hr

** EXTENDED TIME DELAYS GREATLY REDUCE ENERGY SAVINGS

FUNCTION #6 - MICROPHONE (ACOUSTIC DETECTION) SETTINGS

SETTING #	DESCRIPTION
2	Normal Operation (default)
3	Reduced Sensitivity
4	Disabled

FUNCTION #7 - LED INDICATION SETTINGS

SETTING #	DESCRIPTION
2	White LED for all occupancy, normal brightness (default)
3	White LED for all occupancy, increased brightness
4	Disable LED
5	White LED for PIR, blue for Acoustic, normal brightness
6	White LED for PIR, blue for Acoustic, increased brightness

FUNCTION #14 - AUXILIARY RELAY OPERATION

SETTING #	DESCRIPTION
2	Disabled
3	Relay closed when occupied (state follows white wire). (default)
4	Relay closed when occupied and insufficient ambient light (state follows Blue wire). Available for SWX-21x-1-AR and SWX-23x-1-AR models.
5	Relay open when occupied (state opposite white wire)
6	Relay open when occupied and insufficient ambient light (state opposite blue wire). Available for SWX-21x-1-AR and SWX-23x-1-AR models.

DAYLIGHT HARVESTING & PHOTOCELL CONFIGURATION

Along with occupancy based control, units with an integrated photocell can provide on/off or inhibit-only control of lighting based on the amount of ambient light present. Units with the daylight harvesting option can also directly dim 0-10V lighting. See the model number table on page 1 for details on included features for each unit. Descriptions of modes are below.

DAYLIGHT HARVESTING

- Recommend for spaces where it is important to not distract occupants (e.g., offices, classrooms).
- Lights will gradually dim in order to maximize energy savings while maintaining desired overall lighting level.
- Option to dim to low trim or turn lighting off.

ON/OFF PHOTOCELL CONTROL

- Recommended for public spaces (hallways, entryways, etc) where fully switching of lighting off and on will not cause distraction of occupants.
- Lights are switched off if ambient light level surpasses threshold and back on if level drops.

INITIAL INHIBIT ONLY PHOTOCELL CONTROL

- Lighting is held off if sufficient ambient light level is present upon initial occupancy.
- Lighting will turn on if light level drops below setpoint.
- Once on, lighting will only turn off from vacancy or a manual switch, never from daylight.

FUNCTION #3 - PHOTOCELL OPERATIONAL MODE

To enable/disable the operation of the photocell (in equipped units), use the following procedure:

CHANGING THE PHOTOCELL OPERATIONAL MODE:

1. Press and release the unit's pushbutton 3 times, then wait 2 seconds. The white LED will blink back the number of the current setting (repeats 3 times before exiting).
2. At any time after blink back starts, enter number of new setting from table on right (e.g., 3 for Occupancy + Daylight Harvesting).
3. New setting is saved after white LED blinks back new number 3 times. If blue LED double flashes at any time, new setting was not saved and process must be repeated.

PHOTOCELL OPERATION NOTES

During periods of occupancy, all sensors with an integrated photocell (models SWX-21x-1, SWX-23x-1) will signal power packs connected to its **blue wire output** to turn lighting off when the measured light level is high enough for 5 min. such that turning the lights off will not drop the level below the selected setpoint. During this 5 min. transition time the LED will blink blue at 0.5 second intervals. After lights are turned off, the sensor's LED double blinks blue every 15 seconds as an indication that sufficient ambient light is the reason the lights are being held off. If the ambient light level falls below the setpoint for more than 45 seconds, lights will switch back on. During this transition time the LED also will blink blue at 0.5 second intervals.

FUNCTION #4 - PHOTOCELL SETPOINT

The minimum overall light level that is to be maintained in a space by the sensor is referred to as the "setpoint". This value is user selectable or can be chosen by the Auto-Setpoint function that is built into the sensor.

SETPPOINT CONFIGURATION

1. Read through the below setpoint values list and note the number of the desired setpoint (e.g., default is 7 = 25 fc).
2. Press and release the unit's pushbutton 4 times, then wait 2 seconds. The LED will blink back the value of the current setting in two alternating digits:
Blue LED = 10's digit (1-12 blinks or rapid blink for 0)
White LED = 1's digit (1-9 blinks or rapid blink for 0)
3. At any time after blinking starts, enter number of new setting (see table below).
4. New setting is saved after white LED blinks new setting back 3 times. If blue LED double flashes at any time, an error condition exists and process must be repeated.

FUNCTION #4 - SETPOINT VALUE TABLE

SETTING #	DESCRIPTION
2	Run Auto-Setpoint*
3	2.5 fc
4	5.0 fc
5	10.0 fc
6	15.0 fc
7	25 fc (default)
8	35 fc
9	50 fc
10	75 fc
11	100 fc

} **Manual Setpoint Options**

FUNCTION #3 - PHOTOCELL OPERATIONAL MODES

SETTING #	DESCRIPTION	MODEL # NOTES
2	Occupancy + On/Off Photocell Control (Photocell Enabled)	Default for SWX-21x-1 & SWX-23x-1
3	Occupancy + Daylight Harvesting to Off Photocell Control (Photocell Enabled)	Default for SWX-21x-1-D & SWX-23x-1-D
4	Occupancy + Initial Inhibit Photocell Control (Photocell Enabled)	
5	Occupancy only (Photocell Disabled)	
6	Occupancy + Daylight Harvesting to Low Trim (Photocell Enabled)	

*AUTO-SETPPOINT SELECTION DETAILS

- Once setting 2 "Run Auto-Setpoint" has been selected (by following steps 1-4 on left), the sensor's LED will alternate blue and white for 30 seconds. During this time user should move away from sensor.
- Lights will then be cycled in order for sensor to calculate the controlled (artificial) light level. This is done by subtracting the light level with the lights off (relay open) from the light level with the lights on (relay closed).
- A setpoint will then be chosen using the following conditions:
 - If controlled level is less than 3 fc, the application is considered open loop and the setpoint will be set to 25 fc.
 - If controlled level is between 3 and 100 fc, setpoint will be set to that level times 1.25.
 - If controlled level is greater than 100 fc the setpoint will be set to 125 fc.
- Unit will immediately start operating with new setpoint (i.e. blue LED may begin flashing indicating it will transition lights soon)
- To check auto selected setpoint, press and release button 4 times. Setpoint will be blinked back in two alternating digits:
 Blue LED = 10's digit (1-9 blinks or rapid blink for 0)
 White LED = 1's digit (1-9 blinks or rapid blink for 0)

DIMMING CONFIGURATION SETTINGS

CHANGING DETAILED DIMMING SETTINGS

The settings listed in the below function tables can be adjusted using the following programming procedure.

- 1 From the below tables of detailed functions, note the number (#) of the function to be modified. For example, the **HIGH TRIM** setting is #9.
- 3 To access a particular function, press and release the programming button the number of time of the chosen function. For example, press the button 9 times to access the **HIGH TRIM** function.
- 4 The LED will flash back white the setting number of the current value as it appears in each function's detailed table below. For example, the default **HIGH TRIM** is setting #2 (10V)
- 5 To change the setting number, press and release the button the number of times equal to the new setting #. For example, 3 times (for 9V).
- 6 The LED will flash back white the new setting number as confirmation and will be saved after three confirmations. If LED double flashes blue at any time, start process over.

DETAILED DIMMING FUNCTION TABLES

FUNCTION #5 - TURN OFF SCHEME

The method by which a sensor with daylight harvesting (dimming) turns off connected lighting.

SETTING #	VALUES	NOTES
2	Drop to Off	Dimming output drops to low trim level & connected power pack's relay is signaled to open (i.e. blue wire goes low).
3	Fade to Off (default)	Dimming output fades to low trim and connected power pack's relay is signaled to open (i.e. blue wire goes low).
4	Fade to 0V	Dimming output fades to low trim level and then drops to 0 volts (e.g. below a connected driver's electronic off level). The connected power packs's relay is signaled to remain closed (i.e. blue wire stays high).
5	Fade to Low Trim	Dimming output fades down to low trim level and the connected power packs's relay is signaled to remain closed (i.e. blue wire stays high).
6	Drop to Low Trim	Dimming output drops down to low trim level and the connected power packs's relay is signaled to remain closed (i.e. blue wire stays high).
7	Drop to 0V	Dimming output drops to 0 volts (e.g. below a connected driver's electronic off level and the connected power packs's relay is signaled to remain closed (i.e. blue wire stays high).

FUNCTION #9 - HIGH TRIM

The maximum voltage to which the daylight harvesting sensor is allowed to raise its dimming output when measuring a low level of ambient light.

SETTING #	VALUES	NOTES
2	-10 VDC (default)	Light output at each voltage level depends on driver/ballast and luminaire.
3	-9 VDC	
4	-8 VDC	
5	-7 VDC	
6	-6 VDC	
7	-5 VDC	

FUNCTION #10 - LOW TRIM

The minimum voltage to which the daylight harvesting sensor is allowed to reduce its dimming output when measuring high levels of ambient light.

SETTING #	VALUES	NOTES
2	-0 VDC	Light output at each voltage level depends on driver/ballast and luminaire.
3	-1 VDC	
4	-2 VDC	
5	-3 VDC (default)	
6	-4 VDC	
7	-5 VDC	
8	-6 VDC	

FUNCTION #11 - FADE OFF TIME

Adjustable time interval for lights to ramp down to off. Note that the signal on the blue output wire will wait until the Fade Off Time has completed before transitioning from high to low.

SETTING #	VALUES
2	0.75 Sec
3	1.5 Sec (default)
4	3 Sec
5	5 Sec
6	15 Sec
7	Disabled

FUNCTION #12 - FADE ON TIME

Adjustable time interval for lights to ramp up when connected occupancy sensors signal an occupied state.

SETTING #	VALUES
2	0.75 Sec
3	1.5 Sec (default)
4	3 Sec
5	5 Sec
6	15 Sec
7	Disabled

