

Product Overview

Input Voltage (Vac)	Output Power (W)	Output Voltage Range (V)	Output Current Range (A)	Efficiency@ Max Load and 70°C Case	Max Case Temp. (°C)	Input Current (Arms)	Max. Input Power (W)	Inrush Current (Apk/50%-µs)	THD @ Max Load (%)	Power Factor @ Max Load	Surge Protection Common/Diff (KV)	Weight (Lbs/kgs)	Envir. Protection Rating
347	75	25-75	0.35 - 1.2A	88.5	85 °C	0.25	85	52 / 110	<10%	>0.95	4/4	1.9/0.86	UL damp and dry
480				89		0.18		73 / 120	<15%				

Wire Diagram

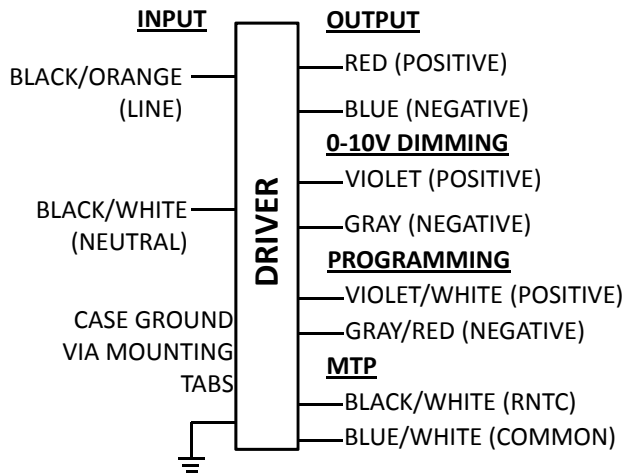

Product Data:

Input and output use lead-wires.
Lead-wires are 18AWG 105C/600V solid copper per UL1452.
Lead Length outside enclosure: 460 mm (±30mm) on all wires

Dimming	Dimming Range	Minimum Output Current (A)	Other Comments
0-10V Analog Class 1 or 2 Wiring Shutdown= Yes (see specification)	10% ~ 100%	0.1	Dimming source current: 150 µA (±3%)

Enclosure



	in.	mm
Case Length	8.44	214.4
Case Width	2.35	59.8
Case Height	1.48	37.6
Mounting Length	8.91	226.2
Overall Length	9.47	240.5



Revised 02/14/2014

Xitanium XH075C120V075KPF1

75W 1.2A sProg -F 347-480V

Electrical Specifications

All the specifications are typical and at 25°C Tcase unless specified otherwise.

XH075C120V075KPF1	
Brand Name	XITANIUM
Description	Xitanium 75W 1.2A sProg -F 347-480V
Input	347 ~ 480V
Input Freq.	50/60Hz
RoHS	Yes
Status	Released

Order code	XH075C120V075KPF1
Full product code	XH075C120V075KPF1M (Mid Pack)
Full product name	XITANIUM 75W 1.2A PROG -F 347-480V
Line Voltage	347-480Vac_rms
Line Current	0.25A @ 347V, 0.18A @ 480V
Line Frequency	50/60Hz
Min. Mains voltage operational	312 V [min]
Max. Mains voltage operational	504V [max]
THD (total)	Refer to graph
Power Factor (PF)	Refer to graph
Inrush Current	Per NEMA 410
Lightning Surge Protection	Refer to table below
Output voltage range	25V to 75Vdc
Maximum open circuit voltage	100V (±5%)
Output Current Ripple (ripple = peak to average / average)	15% max @ max lout Low frequency (≤120 Hz) content <5%
Protections	Short Circuit and Open Circuit Protection for LED + and LED-
Ambient Temp Range	-40C to +55C
Max Case Temperature (Tcase)	85°C
Interfaces	0-10V Dimming
AOC (Adjustable Output Current)	YES, Programmable via MultiOne
MTP (Module Temperature Protection)	YES, Programmable via MultiOne
0-10V Dimming Specifications	150µA source current from driver, See dim curve for detail.
Environmental Protection Rating	UL damp and dry
Agency Approbations	UL879, UL1012, UL935, (cRUs/CSA)
Electromagnetic Compliance	FCC Title 47 Part 15 Class A
Isolation	Refer to table
Audible noise	<24dB Class A

Programming Tool:

For latest version please check www.philips.com/multione

Notes:

1. The driver can be programmed "off-line" i.e. there is no need to power the driver to program it.
2. Only one driver can be programmer at the time, using the MultiOne tool
3. Exercise caution while handling Common/RNTC and programming wires – as they are not protected against mains and output.
4. All un-terminated leads need to be protected against shorting to themselves or any grounded surface.

Revised 02/14/2014

Xitanium XH075C120V075KPF1

75W 1.2A sProg -F 347-480V

Electrical Specifications

All the specifications are typical and at 25°C Tcase unless specified otherwise.

XH075C120V075KPF1	
Brand Name	XITANIUM
Description	Xitanium 75W 1.2A sProg -F 347-480V
Input	347 ~ 480V
Input Freq.	50/60Hz
RoHS	Yes
Status	Released

0-10V Dimming Curve:

Dimming source current from the driver: 150 μ A (\pm 3%) (@ 0<Vdim<8V)

Minimum Dim Level: 10% of Iout (minimum 100 mA)

Guaranteed Driver shutdown @Vdim >14.5V

Typ. sink current: 3mA (4mA Max) at 16V dim

Guaranteed no shutdown driver with Vdim<12V

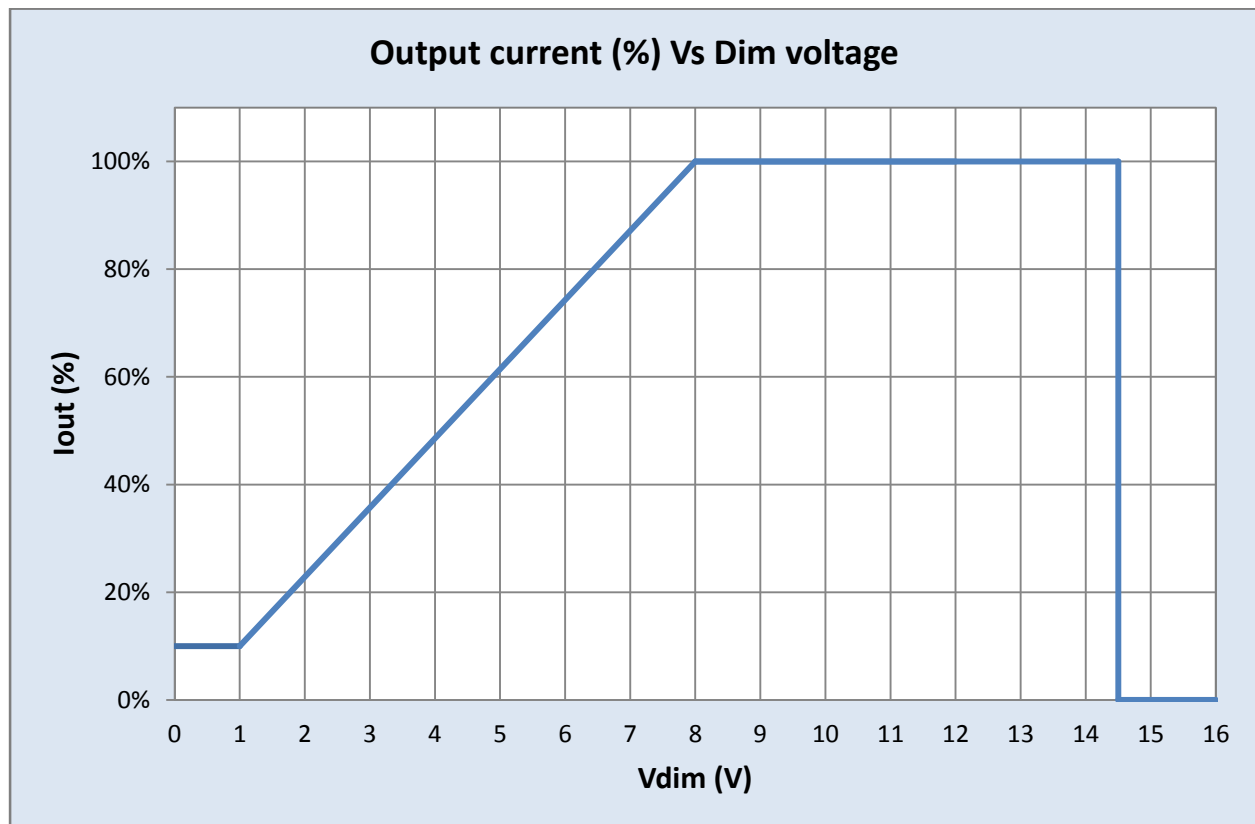

Revised 02/14/2014

Xitanium XH075C120V075KPF1

75W 1.2A sProg -F 347-480V

Electrical Specifications

All the specifications are typical and at 25°C Tcase unless specified otherwise.

XH075C120V075KPF1	
Brand Name	XITANIUM
Description	Xitanium 75W 1.2A sProg -F 347-480V
Input	347 ~ 480V
Input Freq.	50/60Hz
RoHS	Yes
Status	Released

Operating Window:

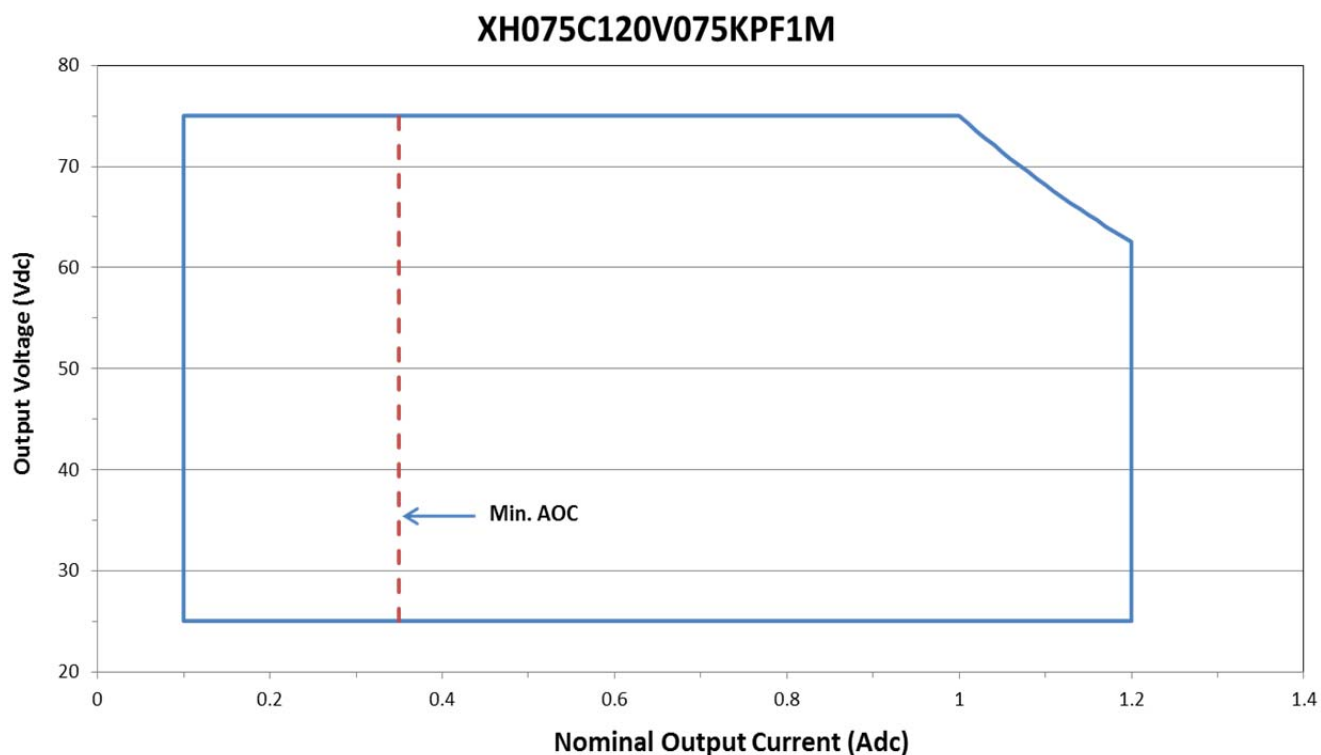

Revised 02/14/2014

Xitanium XH075C120V075KPF1

75W 1.2A sProg -F 347-480V

Electrical Specifications

All the specifications are typical and at 25°C Tcase unless specified otherwise.

XH075C120V075KPF1	
Brand Name	XITANIUM
Description	Xitanium 75W 1.2A sProg -F 347-480V
Input	347 ~ 480V
Input Freq.	50/60Hz
RoHS	Yes
Status	Released

Module Thermal Protection

Default programmed values	Min delta (R Start Dim – R Stop Dim)	Dimming range	Missing NTC Signal
R Start Dim: 2263 Ω R Stop Dim: 1757 Ω	500 ohms	100% to 10% (min current limited to 100mA)	NO

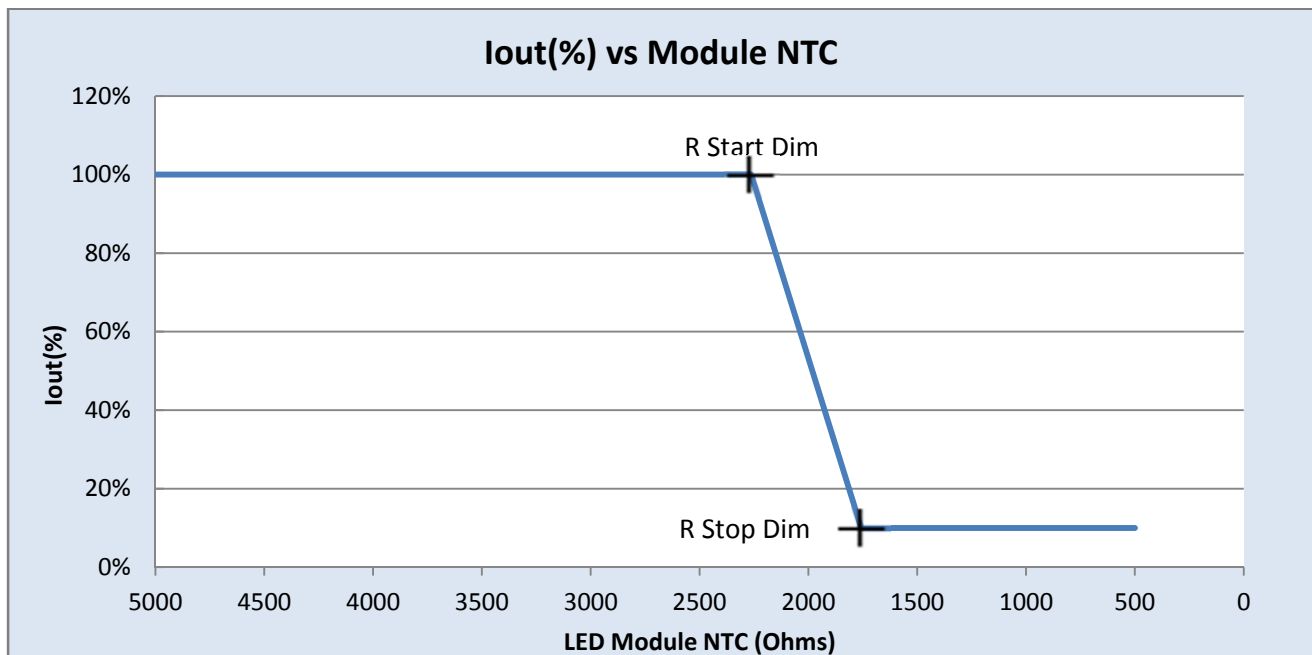

Revised 02/14/2014

Xitanium XH075C120V075KPF1

75W 1.2A sProg -F 347-480V

Electrical Specifications

All the specifications are typical and at 25°C Tcase unless specified otherwise.

XH075C120V075KPF1	
Brand Name	XITANIUM
Description	Xitanium 75W 1.2A sProg -F 347-480V
Input	347 ~ 480V
Input Freq.	50/60Hz
RoHS	Yes
Status	Released

Iout vs. Tcase of Driver:

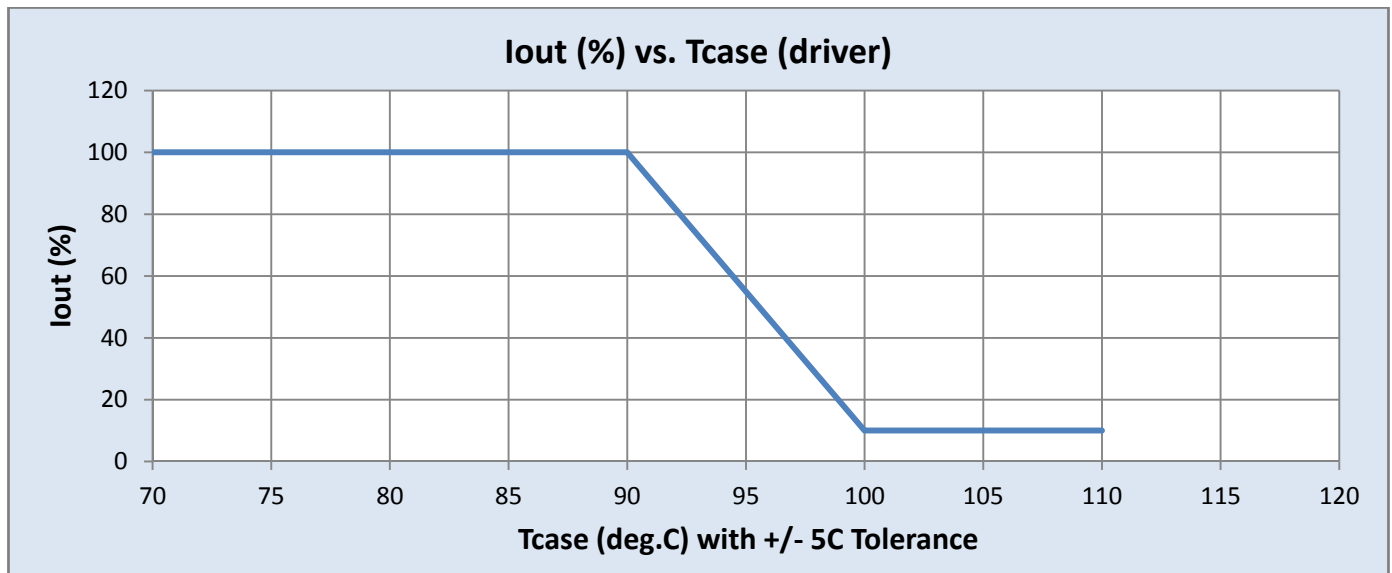

Lifetime vs. Tcase of Driver:

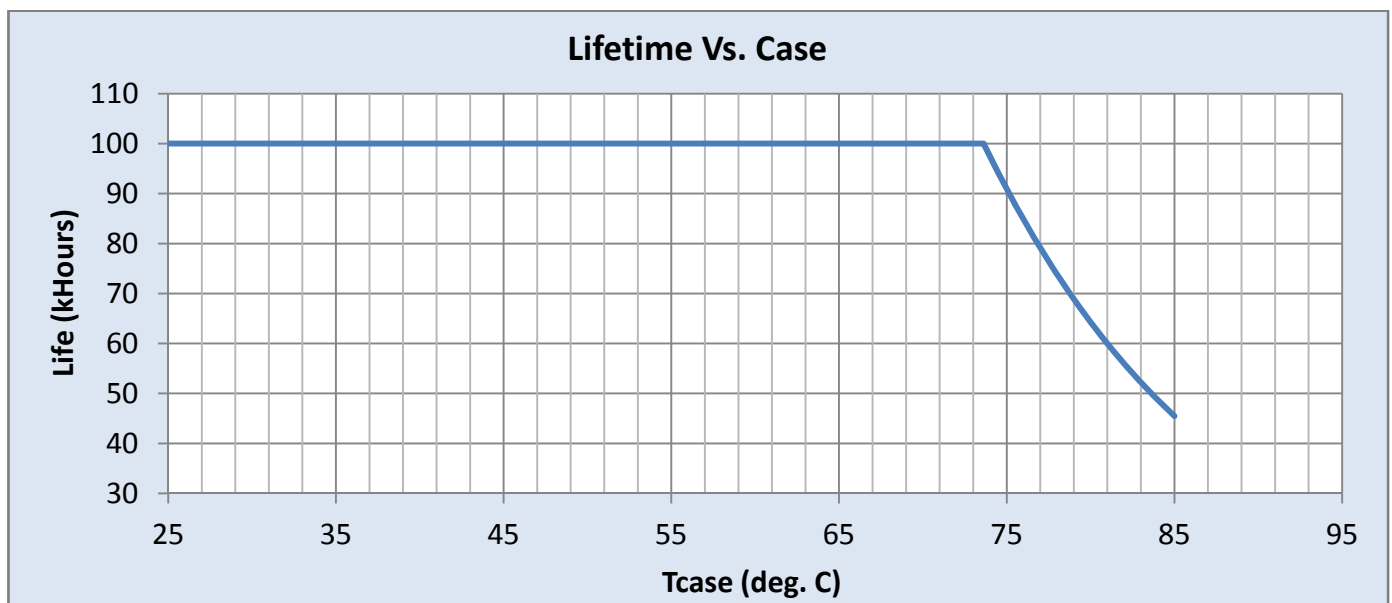

Revised 02/14/2014

Xitanium XH075C120V075KPF1

75W 1.2A sProg -F 347-480V

Electrical Specifications

All the specifications are typical and at 25°C Tcase unless specified otherwise.

XH075C120V075KPF1	
Brand Name	XITANIUM
Description	Xitanium 75W 1.2A sProg -F 347-480V
Input	347 ~ 480V
Input Freq.	50/60Hz
RoHS	Yes
Status	Released

Inrush Current Info:

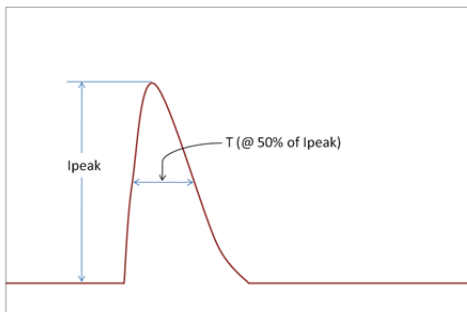

V_{in}	I_{peak}	$T (@ 50\% \text{ of } I_{peak})$
347 Vrms	52 A	110 μ s
480 Vrms	73 A	120 μ s

Inrush current is measured at peak of the corresponding line voltage, source impedance per NEMA 410.

Lightning Surge Info:

ANSI Surge Type	Differential Mode (L-N)	Common Mode (L-G, N-G, L&N-G)
100 kHz Ring Wave (w/t 30 Ω)	6kV	6kV
1.2/50 μ s - 8/20 μ s Combination Wave (w/t 2 Ω)	4kV	4kV

Revised 02/14/2014

Xitanium XH075C120V075KPF1

75W 1.2A sProg -F 347-480V

Mechanical Specifications

XH075C120V075KPF1	
Brand Name	XITANIUM
Description	Xitanium 75W 1.2A sProg -F 347-480V
Input Voltage	347 ~ 480V
Input Freq.	50/60Hz
RoHS	Yes
Status	Released

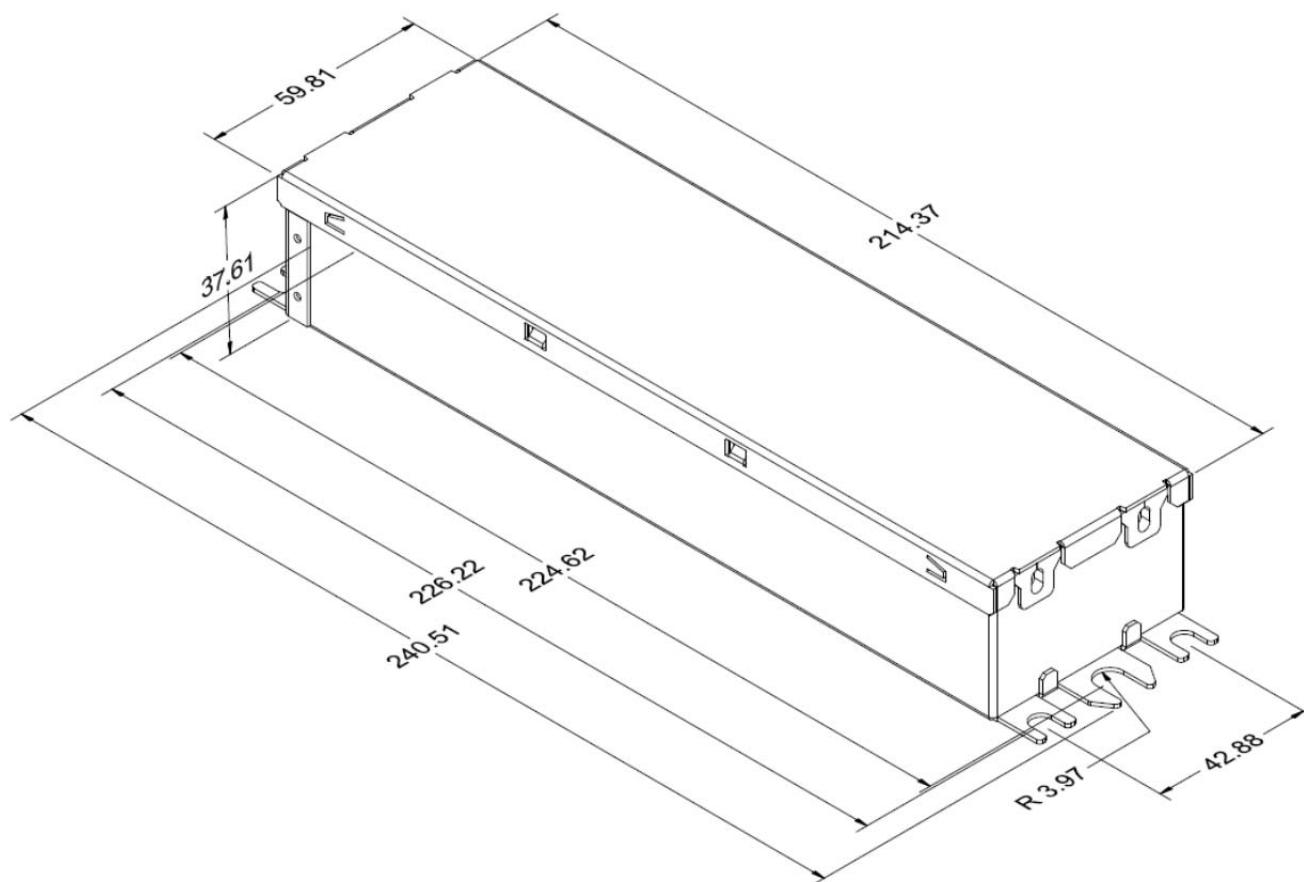

Revised 02/14/2014

Xitanium XH075C120V075KPF1

75W 1.2A sProg -F 347-480V

Performance Characteristics

Based on measurements on a typical sample. The accuracy of the measurements is within the tolerance of the measurement instruments. The graphs are meant to be a guideline and not a specification.

XH075C120V075KPF1	
Brand Name	XITANIUM
Description	Xitanium 75W 1.2A sProg -F 347-480V
Input Voltage	347 ~ 480V
Input Freq.	50/60Hz
RoHS	Yes
Status	Released

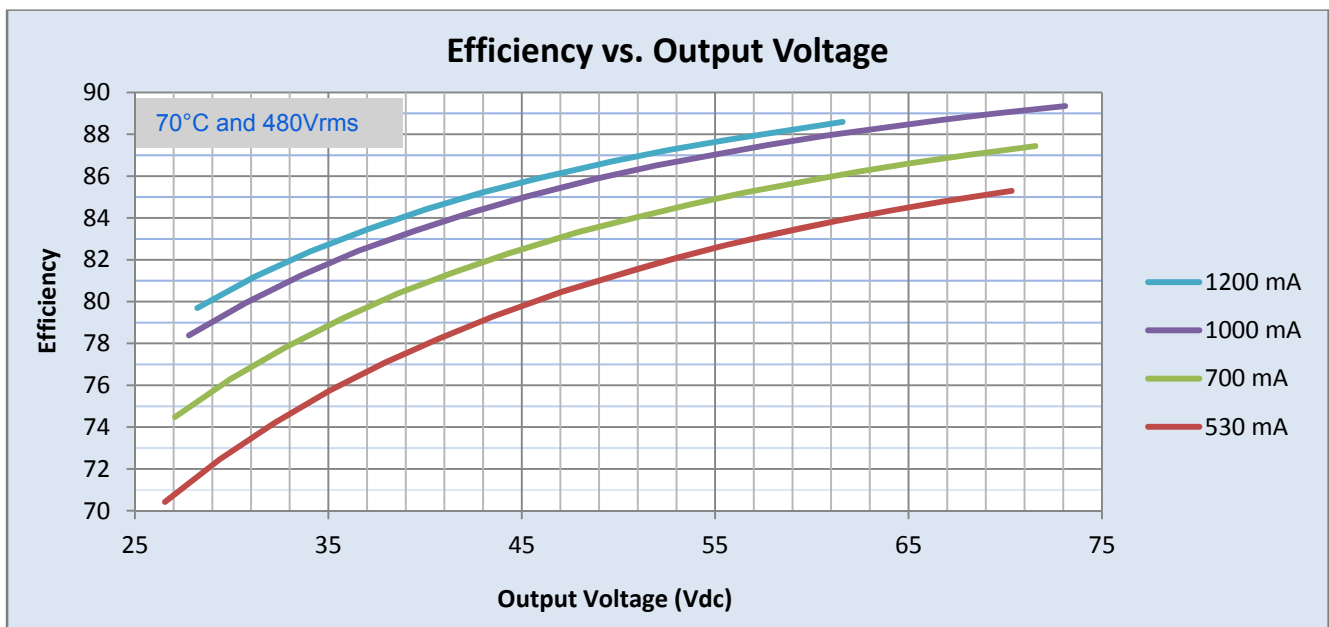
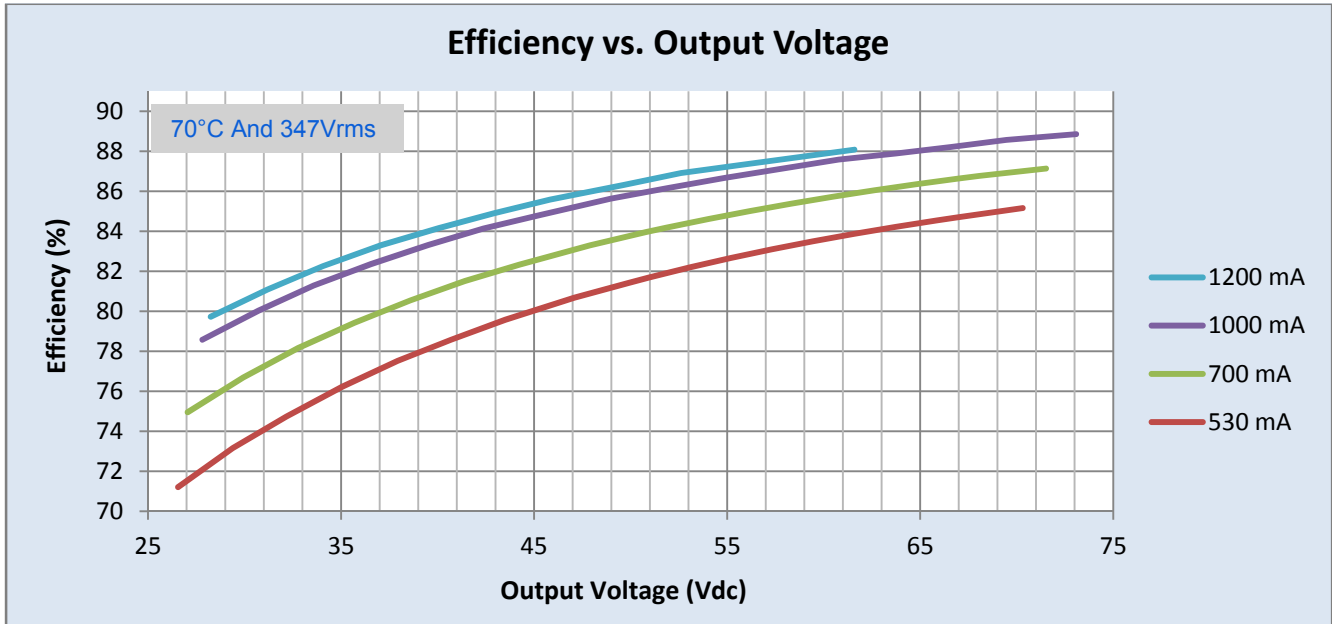

Revised 02/14/2014

Xitanium XH075C120V075KPF1

75W 1.2A sProg -F 347-480V

Performance Characteristics

Based on measurements on a typical sample. The accuracy of the measurements is within the tolerance of the measurement instruments. The graphs are meant to be a guideline and not a specification.

XH075C120V075KPF1	
Brand Name	XITANIUM
Description	Xitanium 75W 1.2A sProg -F 347-480V
Input Voltage	347 ~ 480V
Input Freq.	50/60Hz
RoHS	Yes
Status	Released

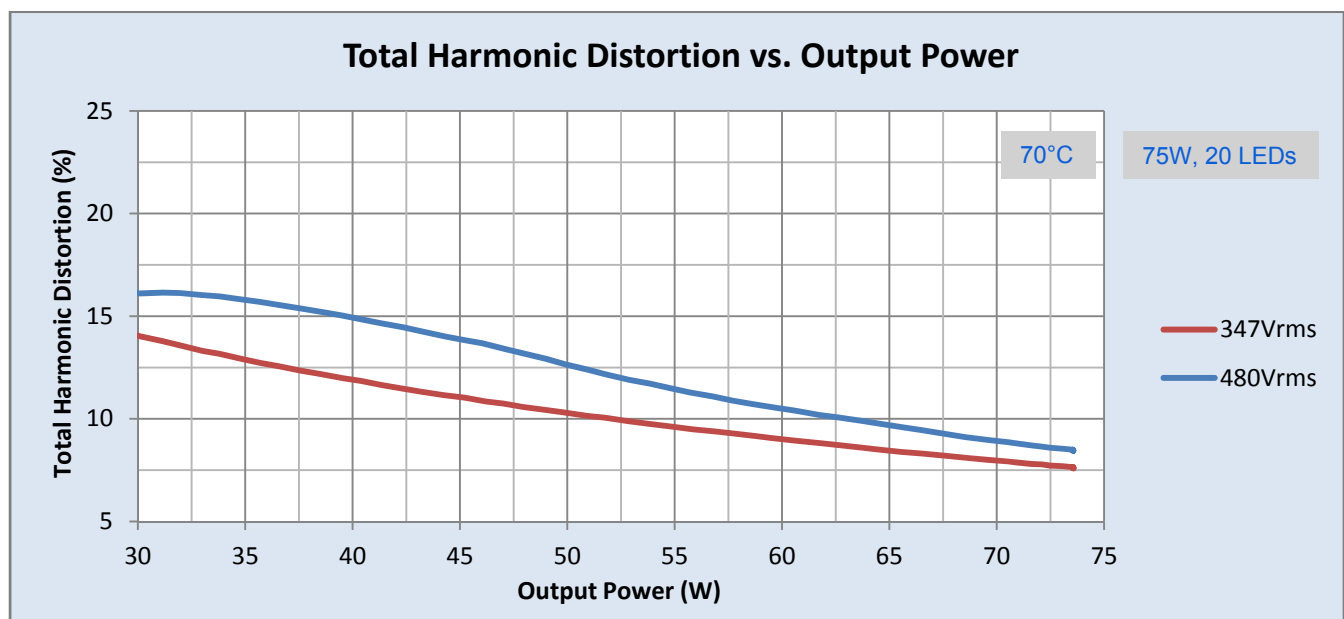
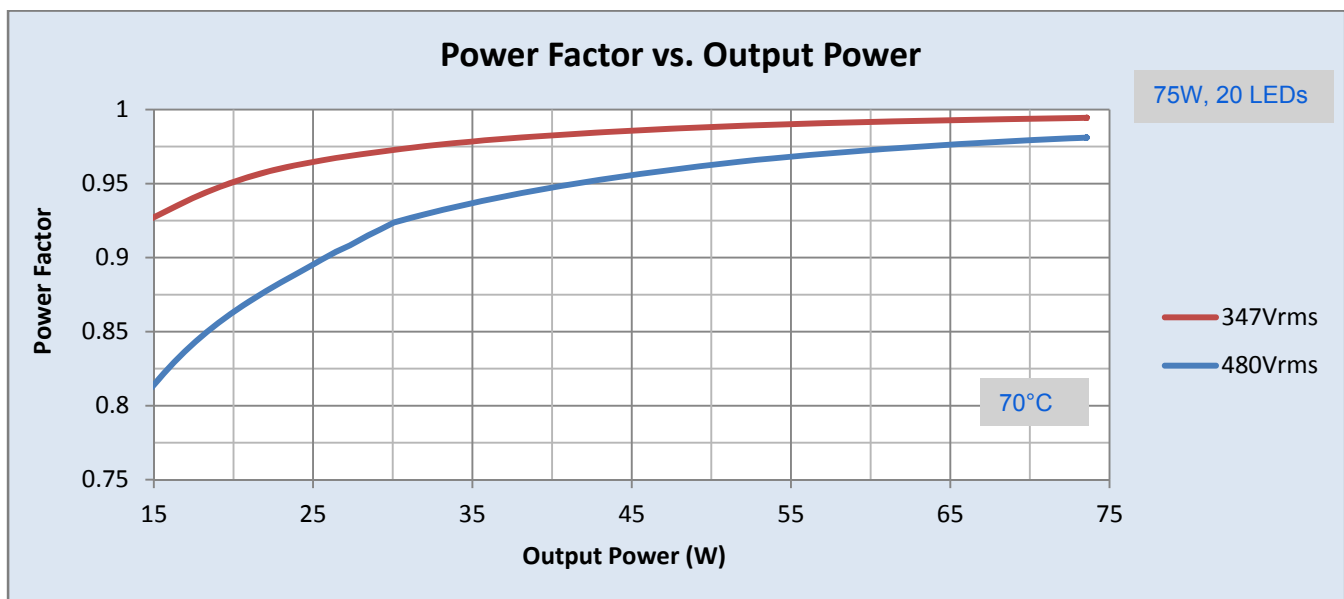

Revised 02/14/2014

Xitanium XH075C120V075KPF1

75W 1.2A sProg -F 347-480V

Application Notes

XH075C120V075KPF1	
Brand Name	XITANIUM
Description	Xitanium 75W 1.2A sProg -F 347-480V
Input Voltage	347 ~ 480V
Input Freq.	50/60Hz
RoHS	Yes
Status	Released

Isolation:

Isolation	Input Wires	Output Wires	0-10V Wires (Class 1 & 2)	Enclosure
Input Wires	Not applicable	2xU+1KV	2.5KVac	2xU+1KV
Output Wires	2xU+1KV	Not applicable	2.5KVac	2xU+1KV
0-10V Wires (Class 1 & 2)	2.5KVac	2.5KVac	Not applicable	2.5KVac
Enclosure	2xU+1KV	2xU+1KV	2xU+1KV	Not applicable

UL Conditions of Acceptability:

Please contact your representative for a copy of the latest UL Conditions Of Acceptability (COA).

The information presented in this document is not intended as any commercial offer and does not form part of any quotation or contract.

