



# D10CC30UNVTW-L/LS

## 1050mA LED Driver w/ Constant Power Tuning

- Universal (120-277V) Input Voltage
- Class 2, 30W Constant Current Output
- 0-10V Dimming to 1%



### Performance

Input Voltage	120 ~ 277 Vac ± 10%
Input Current Max	0.29 /120V 0.13/277V
Input Power Max	36W
Input Frequency	50 - 60 (Hz)
Power Factor*	> 0.95
THD max*	< 20 %
Output Voltage	15V to 30V @ 1.050 Amps (See Power Curve Chart) 15V to 56V @ 0.530 Amps
Max. Output Current	1050mA
Min. Dimming Current	11mA
Output Power	30W
Line Regulation	±3 %
Load Regulation	±5 %
Output Current Ripple	<10% (Pk-Pk/avg)
Inrush Current	120V: 8.5A / 390uS
Peak / >50% Duration	277V: 11.0A / 390uS

\* Refer to charts for additional information  
 - Harmonic Emissions comply with ANSI C82.77  
 - Inrush current complies with NEMA 410

### Environmental

EMI and RFI	Meets FCC part 15 (Class A) Non-Consumer Limits
Min. Operating Temperature	-40°C (-40°F)
Storage Temperature	-40°C to 85°C (-40°F to 185°F)
tc	85°C (185°F) max
Protection Rating	UL Dry & Damp
Transient Protection	IEEE C62.41 2.5kV

### Physical

Length	4.95 in
Width	2.39 in
Height	1.00 in
Mounting Length (L)	4.61" (feet)
Mounting Length (LS)	2.00" (#8-32 studs)
Weight (lbs)	1
Wire Trap / Plug-in Connectors for 18 AWG Solid Wire	

### Protection

Over voltage, Overload and short circuit, over temp.

### Safety:

UL 8750 & CSA 250.13-12  
UL Type TL

### Ordering Information

Order Number	Description	Qty/Carton
D10CC30UNVTW-LNOC	Multi-Exit	10
D10CC30UNVTWLSNOC	Bottom Exit w/ Studs	10

### Wiring Diagram:

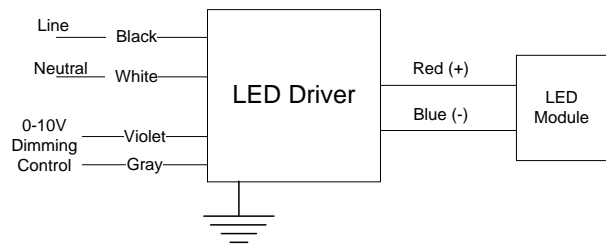

Application and operation performance specification information subject to change without notification.



## Programmable Tuned Output Settings

- This Everline LED Driver can be configured to set its current output to a selected fraction of their maximum rated design level. This function is called tuning (or also high-end trim) and it can be implemented with the LPTC01U using the Selector rotary switches. Tuning assignments are stored in driver memory and are not lost when power is removed. All factory produced drivers are tuned to maximum output unless otherwise noted on the label.
- Tuning SET Levels are listed in the table to the right. The SET Level corresponds to an associated Output Current value.
- Refer to application note EVD09 at [www.unvlt.com](http://www.unvlt.com) for additional information.

Set Value	Output Current (A)
100	1.05
99	1.04
98	1.03
97	1.02
96	1.01
95	1.00
94	0.98
93	0.97
92	0.96
91	0.95
90	0.94
89	0.93
88	0.92
87	0.91
86	0.90
85	0.89
84	0.88
83	0.87
82	0.86
81	0.85

Set Value	Output Current (A)
80	0.84
79	0.83
78	0.81
77	0.80
76	0.79
75	0.78
74	0.77
73	0.76
72	0.75
71	0.74
70	0.73
69	0.72
68	0.71
67	0.70
66	0.69
65	0.67
64	0.66
63	0.65
62	0.64
61	0.63

Set Value	Output Current (A)
60	0.62
59	0.61
58	0.60
57	0.59
56	0.58
55	0.57
54	0.56
53	0.55
52	0.54
51	0.53
50	0.52
49	0.50
48	0.49
47	0.48
46	0.47
45	0.46
44	0.45
43	0.44
42	0.43
41	0.42
40	0.41

## Constant Power Operating Voltage-Current Operating Range

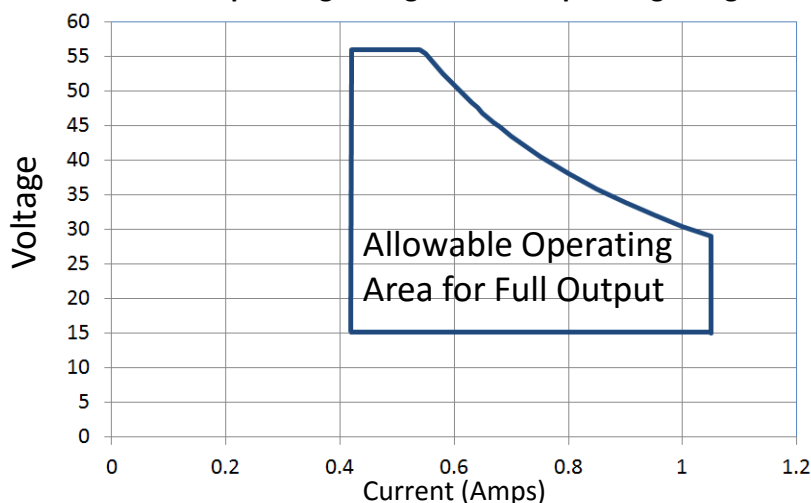

For points along the curve:

- \* Maximum output current will not exceed 1.050A.
- \* Maximum output voltage will not exceed 56V.
- \* Output power ( Volts x Amps) will not exceed 30W.



Application and operation performance specification information subject to change without notification.



## 0-10V Dimming

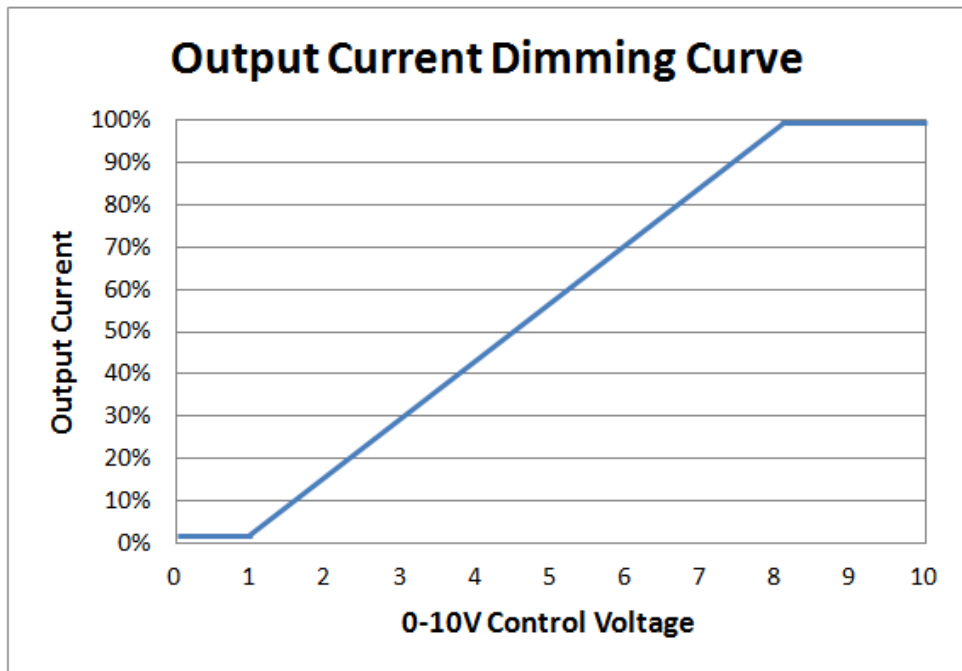

### 0-10V Analog Dimming Interface

- Analog 0 to 10 vDC Voltage Control
- Use Violet (+) & Gray (-) for connection to 0-10vDC.
- 10v = maximum output, 0v = minimum output
- Wiring Violet & Gray together provides min. light output.
- Capping Violet & Gray separately provides 100% light output.
- 0-10V interface must be wired as a Class 2 Circuit.
- Driver will source a maximum of 200uA for control needs.
- Controller must sink current from the 0-10V control leads.

**EVERLINE™**

Application and operation performance specification information subject to change without notification.



## Performance: Efficiency, THD, & Power Factor

Typical performance measurements are shown. The charts are to be used as a guideline and not for specification use.

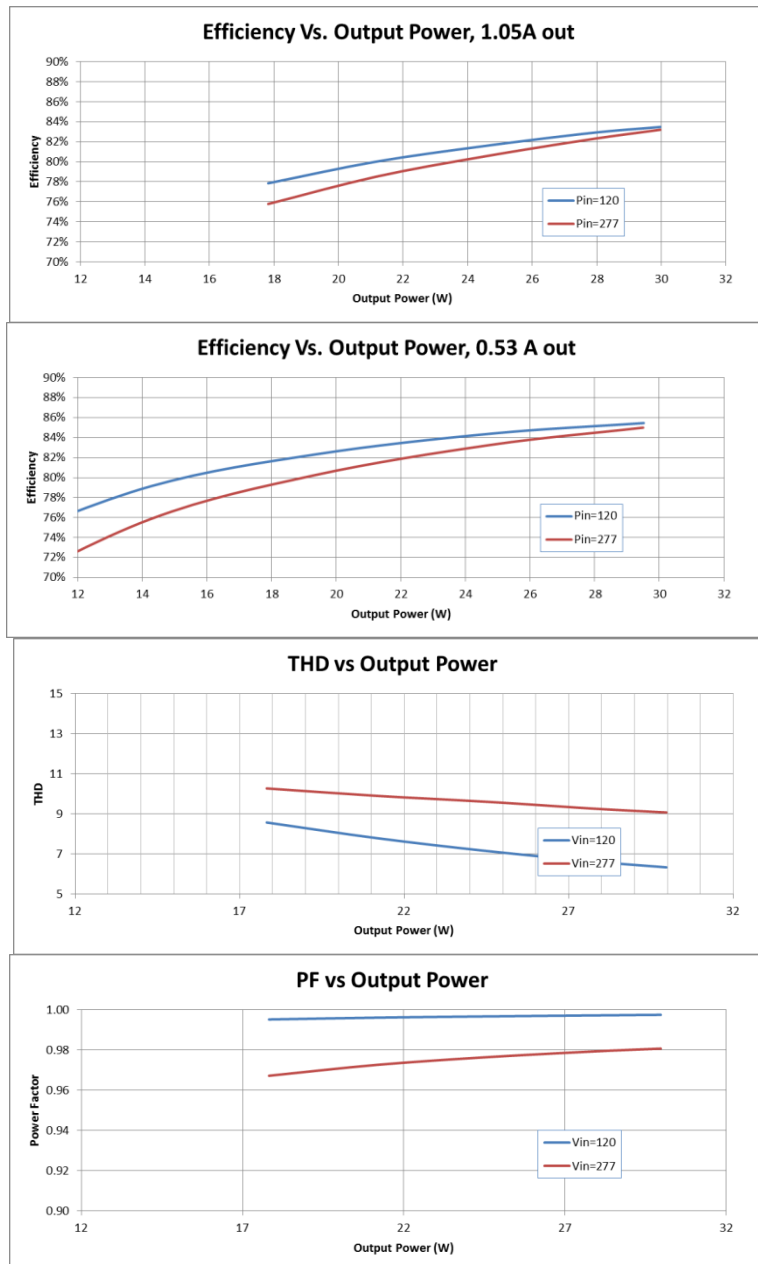

Output power based on varying load voltages.



Application and operation performance specification information subject to change without notification.



# D10CC30UNVTW-L/LS

## Dimensions

-L

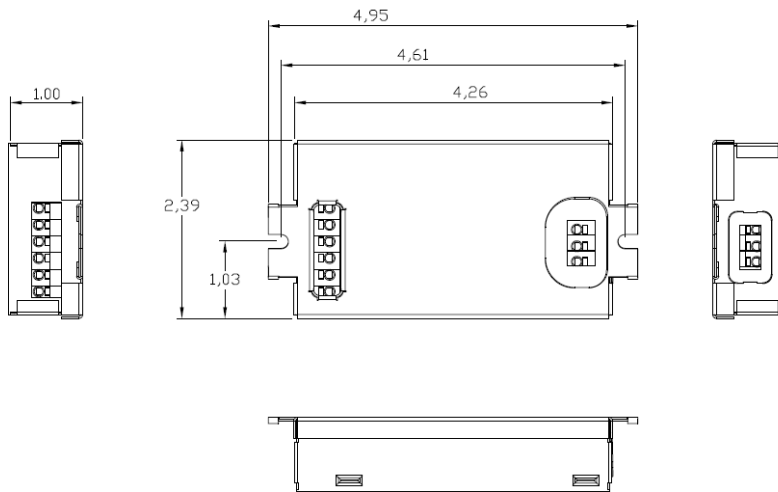

LS

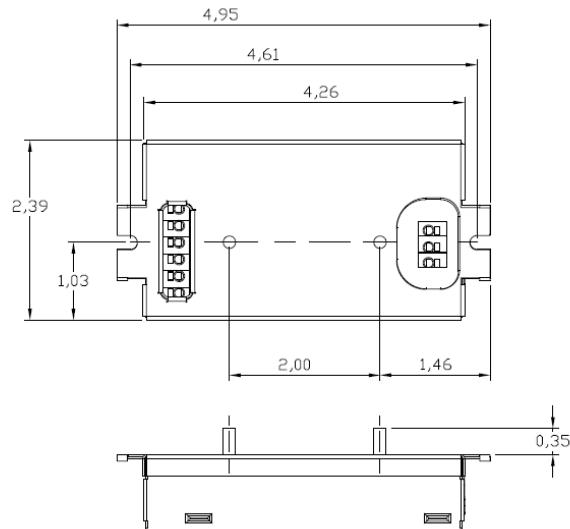

LS Provides lead exits at the bottom only

**EVERLINE**

Application and operation performance specification information subject to change without notification.



## Life vs. Driver Tcase

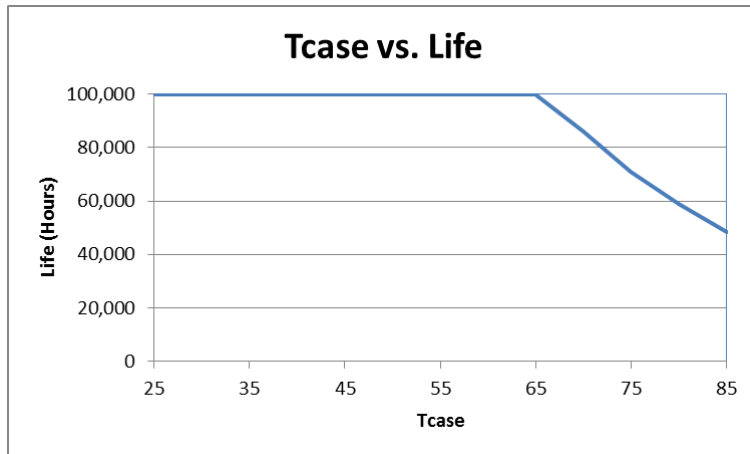

The Data curve provided predicts the LED Driver life based on the case temperature measured at the Tc location identified on the label or specification sheet. The Telecordia SR-332 standard is used to generate the prediction curves.

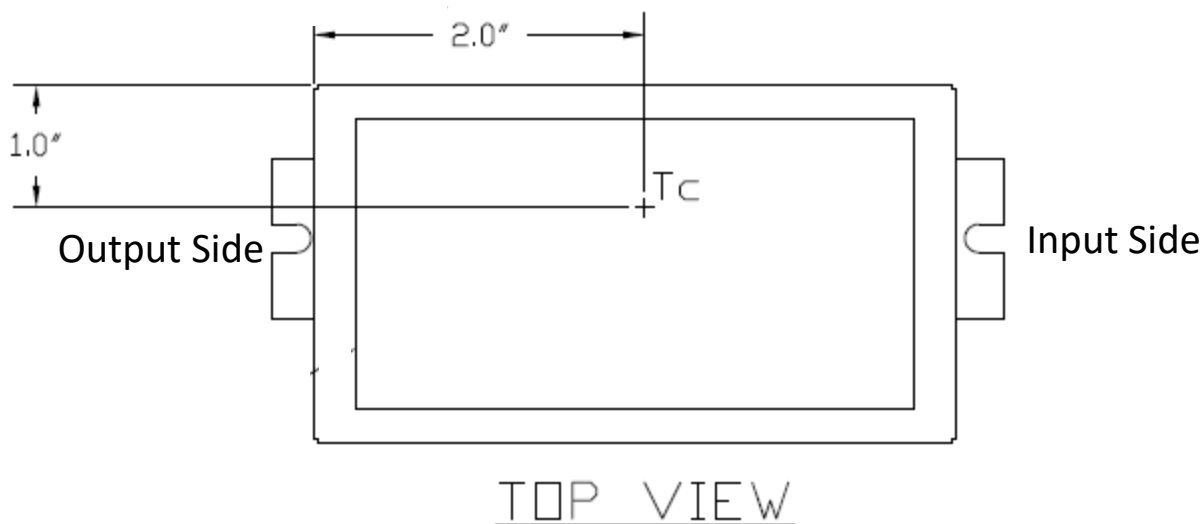

Application and operation performance specification information subject to change without notification.



# D10CC30UNVTW-L/LS

## Condition of Acceptability

-When installed in the end use equipment, the following are among the considerations to be made:

1. These products are intended for building inside the enclosure of the end-use application with no vent openings. Acceptability of the LED driver with respect to mounting, spacing, casualty, temperature and segregation is to be determined as part of the end device evaluation.
2. The Driver was evaluated as Type TL (Temperature Limited) for use at a Tref max and Measured Tref temperature at Tref as shown in the table below. See ILL. 5 for the Tc location on the unit:

Model	Tref max	Measured Tref @40°C Ambient Temperature
D10CC30UNVTW-L	90°C	65°C

3. The driver has been evaluated at the following temperature test condition with the results shown in the table below. See ILL. 5 for the Tc location on the unit:

Model	Operating Conditions	Max Case Temp (Tc)	Ambient
D10CC30UNVTW-L	120Vrms Input	85°C	59°C
	277Vrms Input	85°C	59°C

4. The Ground bonding test was conducted from the green terminal connection to enclosure from a 40 amperes for a period of two minutes and the measured resistance was less than 0.01 ohms.
5. The maximum measured leakage current from the accessible driver enclosure conductively connected to the accessible Class 2 output were as follows:

Model	Maximum Measured Leakage Current MIU	
	120 V	277 V
D10CC30UNVTW-L	0.18	0.51

6. These products are provided with terminal blocks for supply and load connection. These terminals are intended for use with 18 AWG solid copper conductors with 0.33 in. strip length and are suitable for field and factory wiring.
7. These products are marked suitable for dry/ damp locations. Additional considerations will be necessary as these LED drivers are integrated into wet rated end devices (i.e. input and output supply connection means, accessibility of the output based on maximum voltage restrictions for wet rated Class 2 circuits, acceptability of markings, etc.).
8. When driver maximum output current is reprogrammed at the luminaire facility. An additional marking on the driver or luminaire must be provided with the output current the driver has been programmed to deliver.
9. The dimming control circuit for model D10CC30UNVTW-L (-LS) is isolated from the primary circuits and is part of the isolated LED Driver Class 2 circuit and is suitable for Class 2 wiring methods.
10. The output of Driver Model D10CC30UNVTW-L (-LS) is greater than 42 VDC and is LED driver Class 2 Per Annex "A" of CSA C22.2 250.13

FCC Statement: This device complies with part 15 of the FCC Rules. Operation is subject to the following two conditions: (1) This device may not cause harmful interference, and (2) this device must accept any interference received, including interference that may cause undesired operation.

## Warranty:

Universal Lighting Technologies warrants to the purchaser that each power supply will be free from defects in material or workmanship for a period of 5 years from the date of manufacture when properly installed per instructions and under normal operating conditions of use. Call 1-800-225-5278 for technical assistance.



Application and operation performance specification information subject to change without notification.