

# Emergency LED Driver

## LED-EMB-15W-LV-S

### Constant Output Power

#### Features

- Compact and easy to install
- Meet most of safety standards for lighting
- Built-in Lithium Battery
- Battery protections: over charge protection, over discharge protection, short circuit protection
- Indicator shows a variety working modes
- Intelligent emergency self-testing function
- The batteries meet 500 cycles of standard charge and discharge
- Constant output power (Auto-sensing output within each range)

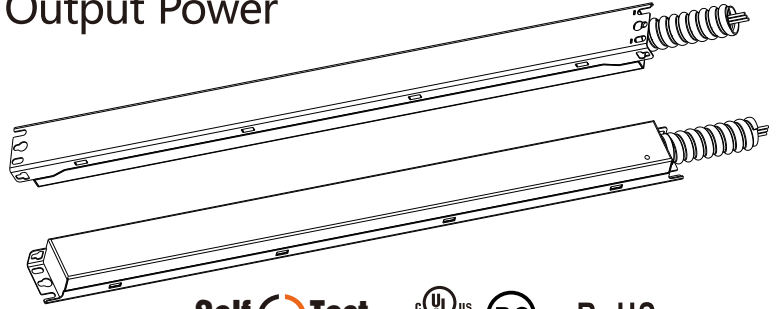

Self Test



RoHS

#### Specifications

<b>Input Voltage</b>	100-277Vac 50/60Hz	<b>Temperature Rating (Ambient)</b>	0°C to +50°C (32°F to 122°F)	<b>Emergency time</b>	90 minutes
<b>AC Input Current</b>	100mA max.	<b>Output Voltage</b>	25V-48Vdc	<b>Output Power</b>	15W
<b>AC Input Power</b>	7.0W max.	<b>Charging Current</b>	≤250mA	<b>Battery (Li-ion battery)</b>	14.8V/2000mAh
<b>Full Warranty</b>	5 Years	<b>Charging Time</b>	≥24Hours		

#### Dimensions:

17.7"x1.26"x0.83" (450mmx32mmx21mm)

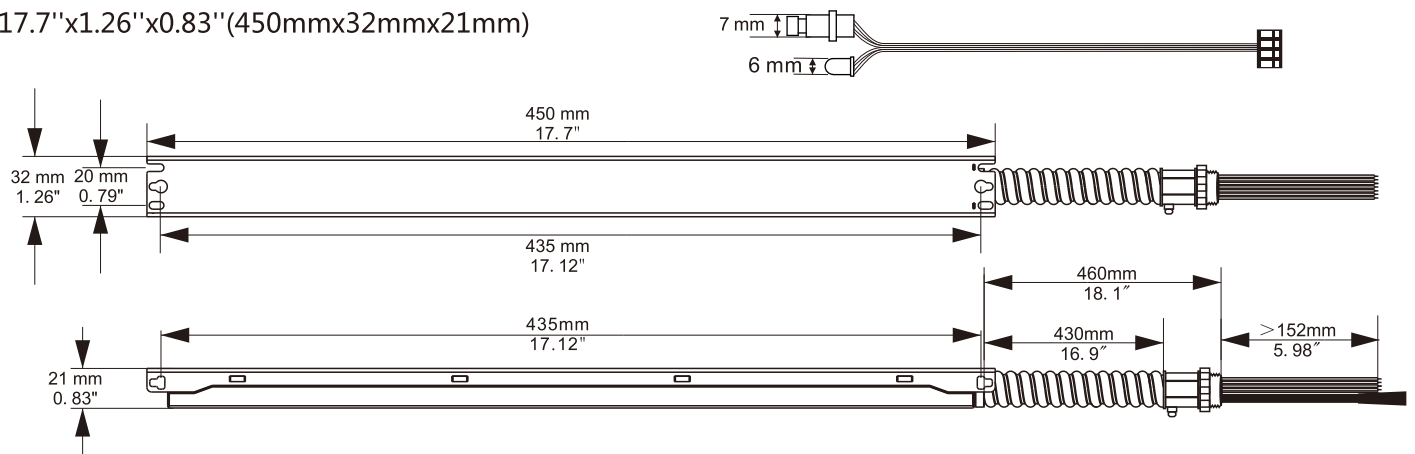

#### Wiring Diagram

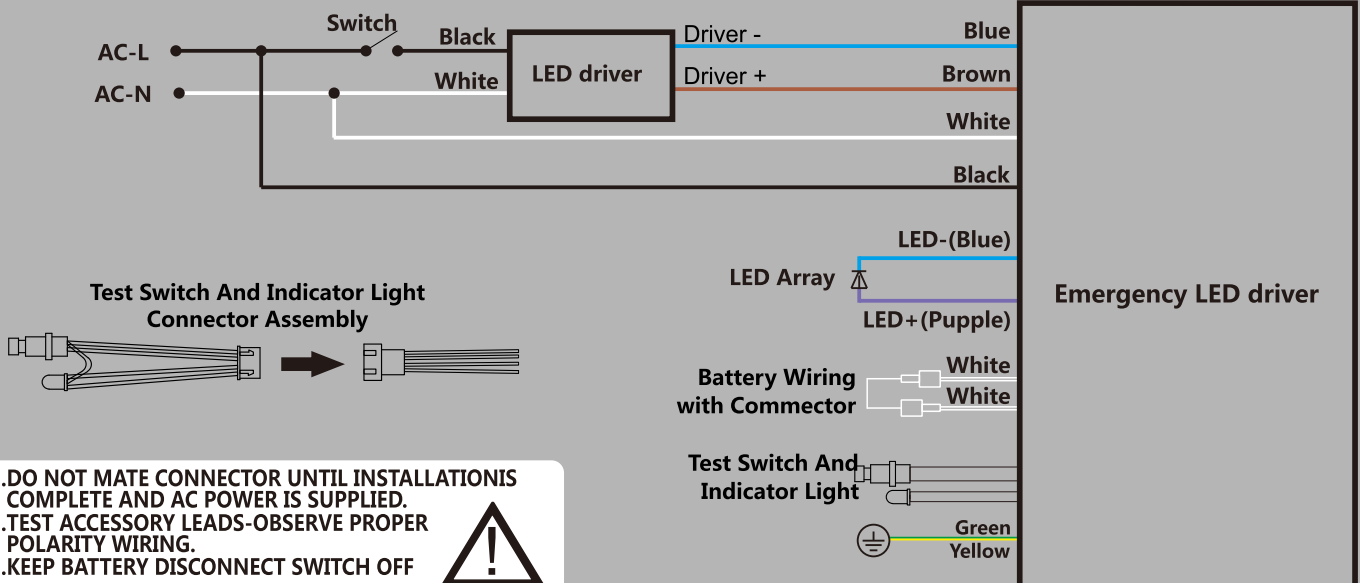

1. DO NOT MATE CONNECTOR UNTIL INSTALLATION IS COMPLETE AND AC POWER IS SUPPLIED.
2. TEST ACCESSORY LEADS-OBSERVE PROPER POLARITY WIRING.
3. KEEP BATTERY DISCONNECT SWITCH OFF DURING STORAGE AND TRANSPORTATION



## Operation

### AC Operation:

AC power is present, The LED load from the LED driver is normal power supply, AC LED driver output current can not exceed 150W or 4A, the emergency driver is charging in a standby mode. The green LED light flashes indicates that it is charging. The green LED light on indicates that it is full charged. After the AC power supply working 48h, The emergency LED drive will automatically from AC power working switch into emergency working mode for 30S every month and then automatically backs to the working mode of the AC power supply, the AC power supply works per year for automatically from the AC power mode backs to the working emergency mode Until the emergency discharge is completed.

### Emergency operation:

When the AC power goes out, The emergency driver detects the AC power outage and automatically switch to the emergency mode.

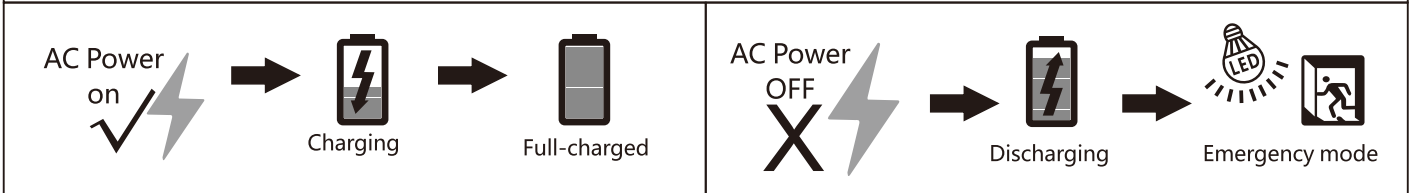

## Indicator light introduction

- ① Green/flashing: Charging
- ② Green/on: Full-charged
- ③ Red/on: Discharging(emergency mode)
- ④ Red/flashing: Discharging(emergency mode) finished soon

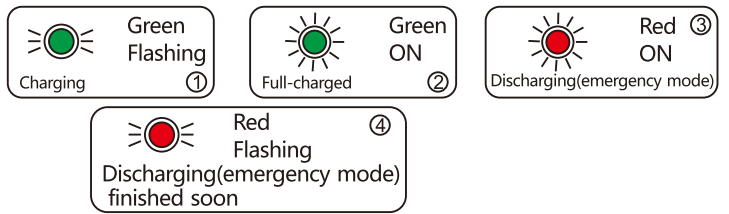

## Test switch introduction

Press the test switch to confirm whether the emergency function is normal



## IMPORTANT SAFEGUARDS

When using electrical equipment, basic safety precautions should always be followed including the following

### READ AND FOLLOW ALL SAFETY INSTRUCTIONS.

- Risk of fire or electric shock. Luminaire wiring and electrical parts may be damaged when drilling for installation of LED Emergency Backup. Check for enclosed wiring and components.
- Risk of fire or electric shock. This LED Emergency Backup installation requires knowledge of luminaire. electrical systems. If not qualified, do not attempt installation. Contact a qualified electrician.
- Before installing, make certain the AC power to the fixture is off.
- The electrical rating of this product is 100-277Vac. Installer must confirm that there is 100-277Vac to the fixture before installation.
- To prevent electrical shock only mate unit connector after installation is complete and before the AC power to the fixture is back on.
- This LED Emergency Backup unit requires an un-switched AC power source of 100-277Vac, 50/60Hz. The AC driver must be on the same branch circuit as the LED Emergency Backup unit.
- Do not let power supply cords touch hot surfaces.
- Do not mount near gas or electric heaters.
- Do not use outdoors.
- Do not connect battery pack connector until all other wiring is complete and AC power is on.
- The emergency LED driver is for use with grounded, UL listed LED luminaires, shall be enclosed by the LED luminaire and bonded to the grounding of LED luminaire.
- Verify that all replacement lamp types marked on the installed luminaire are also identified as suitable for use with this emergency battery pack.
- The battery pack is fixed by the screw and the indicator lamp is attached to the shell of the luminaire by 3M tape.
- Equipment should be mounted in locations and at heights where it is not be subjected to tampering by unauthorized personnel.
- The use of accessory equipment not recommended by the manufacturer and may cause an unsafe condition.
- Do not use this equipment for other than its intended use.
- Use with grounded, UL Listed, dry or damp location rated fixtures.

