

Catalog Number • Numéro de Catalogue • Número de Catálogo: LMBR-650

Country of Origin: Made in China • Pays d'origine: Fabriqué en Chine • País de origen: Hecho en China

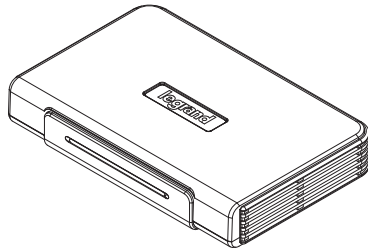

DESCRIPTION

The wireless border router manages the formation and configuration of the 6LoWPAN wireless network and provides network connectivity via wired Ethernet to a local area network (LAN). Wireless network bridge (LMBC-650) devices connect to the border router to establish mesh routing paths. The border router also provides key information about the health of the mesh network in the form of signal quality, device status, network status, and other real-time network information such as energy monitoring. The border router allows cloud connectivity, which can be used to update firmware in all connected wireless devices, as well the LMBR-650 itself.

MOUNTING AND INSTALLATION

Each border router ships with the following components:

- LMBR-650 border router
- LMPB-100 Power Supply
- DC power adapter cable, DC barrel to RJ45 jack
- T-shaped mounting bracket
- Self tapping screws x 3
- Cable tie

Not included:

- LMRJ cable connection between power adapter cable and LMPB-100
- CAT5e network cable for connection to LAN, DLM Management software, and other BACnet devices

If the site will only have a single LMBR-650, it should be mounted as described below. If there are multiple LMBR-650s, one of them will be designated as the **Primary** LMBR and all others will be **Secondary** LMBRs. It is Wattstopper best practice that the Primary LMBR be used only for communication with other LMBRs and not have any wireless devices assigned to its network. Therefore, the Primary LMBR will often be mounted in a network enclosure and will only communicate via ethernet cable and not with its wireless radio.

A single (or secondary) LMBR-650 is intended to be mounted in a central location for optimal communication with wireless devices. It is rated for installation in plenum or non-plenum ceiling spaces. The LMBR-650 should be mounted to a vertical surface, using the included T-shaped bracket, for optimum efficiency of wireless transmission/reception. For projects designed by Wattstopper services, check the drawing for optimal border router placement. Wattstopper recommends a minimum of 10' between the LMBR-650 and another LMBR-650 or any wireless bridges.

1. Using T-shaped mounting bracket, locate a suitable vertical surface to mount the T-shaped bracket with the two screw holes facing down (T upside down orientation as shown). Use provided self tapping screws to mount the T-adapter.
2. Once T-adapter is secure, locate the mounting holes on back side of border router and T-shaped adapter. With the border router network connections facing upward align the border router over the mounting pegs and slide down to lock into place.

NOTE: A single LMBR-650 or a secondary LMBR-650 in a multi-LMBR network should **not** be installed in an enclosure. A primary LMBR-650 can be installed in a network enclosure, since it will communicate via ethernet cable.

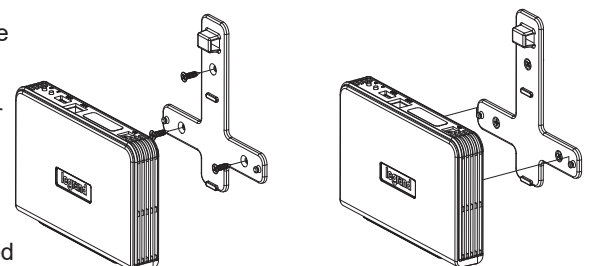

SPECIFICATIONS

Power	
Either	IRB powered using dedicated LMPB-100
..... (included) with DC barrel-to-RJ-45 connector cable	
Or	optional 120VAC plug-in power supply (NB-PS)
Current Consumption	65mA @24VDC
Wireless	IEEE 802.15.4, 2.4GHz
..... IPv6 Mesh (6LoWPAN / 802.15.4 / 2.4GHz), range 100 ft.	
..... Available Channels:	13-24
..... Built-in Antennas:	Two IPv6 Mesh with diversity
..... Bandwidth:	up to 156kbps
Wireless Encryption	AES-128 bit symmetric key
Connections	RJ45 10/100 Ethernet, 1 DC Barrel Connector
Storage	Internal MicroSD Card
Time	Real-time clock with supercap 14 day back-up
Device Capacity	up to 50 LMBC-650s and 250 total devices
1 Primary LMBR-650 can support up to 10 Secondary LMBR-650's	
LEDs	power and network status
Environment	For indoor use only
Operating Temp	32 to 131F (0 to 55C)
Storage Temp	23 to 176F (-5 to 80C)
Relative Humidity	5–95% Non-condensing
Compliance/Regulatory	
UL 2043 Plenum Rated, UL/C-UL (E101196), FCC, RoHS	

POWER OPTIONS AND WIRING

Determine the best power source for the border router.

DLM IRB powered (preferred, easiest method, plenum rated)

1. Connect the barrel end of the DC power adapter cable into the back of the border router.
2. Connect the LMRJ45 end of the adapter cable to the LMPB-100 Power Booster, using an LMRJ cable.
3. Connect a standard network cable to the LMBR-650. The other end should be connected to the switch in a Network cabinet or RACCESS cabinet, if using, or another switch or PC, if not.
4. Secure the cables to the square loop with a cable tie, to provide strain relief.
5. Once the DLM room network is powered up, the border router will begin to power on.
 - If the border router does not power on, check that the LMPB-100 is powered on and that cables are fully inserted.
 - If the border router still does not power on, confirm that there are not too many connected devices in the DLM room network.
6. Once powered on, device will begin boot sequence illuminating LEDs.

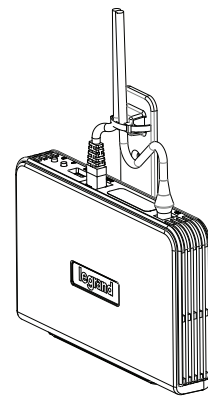

Optional 120VAC powered (not suitable for plenum spaces)

1. A 2 prong AC power adapter (NB-PS) with 4ft length cord can be purchased separately.
2. Install electrical box with receptacle where border router will be installed. (Note: ensure receptacles are not switched.)
3. Connect the barrel connector to the back of the border router and plug in the AC wall adapter to power on the device.
4. Connect a standard network cable to the LMBR-650. The other end should be connected to the switch in a RACCESS cabinet, if using, or another switch or PC, if not.
5. Secure the cables to the square loop with a cable tie, to provide strain relief.
6. Once powered on, device will begin boot sequence illuminating LEDs.

CONNECTION WITH DLM LOCAL NETWORKS AND DLM MANAGEMENT SOFTWARE

The LMBR-650 provides wireless communication with an LMBC-650 wireless bridge connected to a local DLM Network. The LMBR-650 can communicate with up to 50 bridges and 250 room devices. Maximum distance between REED/routing devices is 100 ft.

If more than one LMBR (and up to 11) are being installed at a site, it is Wattstopper best practice that one LMBR (the Primary) be used only for communication with the other LMBRs (for a maximum of 10) and not have any wireless devices assigned to its network. In this case, each LMBR should be connected to a wireless switch via ethernet cable. The Primary LMBR can be installed in the network enclosure, since it will not communicate directly with any wireless devices.

NOTE: If a bridge is installed inside a J-box, the coverage decreases to 75'. The minimum distance between bridges is 6". However, unlike wired bridges, where it can make sense to install several of them next to each other for ease of wiring, Wattstopper recommends installing each bridge a distance close to or in the room it is controlling, instead of bunched together.

The LMBR-650 connects with DLM Programming software (LMCS-100), RACCESS, or other BACnet devices by either connecting them directly with a Cat5e network cable, or by including an NB-Switch, as shown below.

Following is an example of a DLM network with a single LMBR-650, a network enclosure with an NB-Switch, and multiple DLM rooms. Wattstopper recommends a minimum of 10' between the LMBR-650 and another LMBR-650 or any wireless bridges

DLM Rooms with LMBC-650 wireless bridge

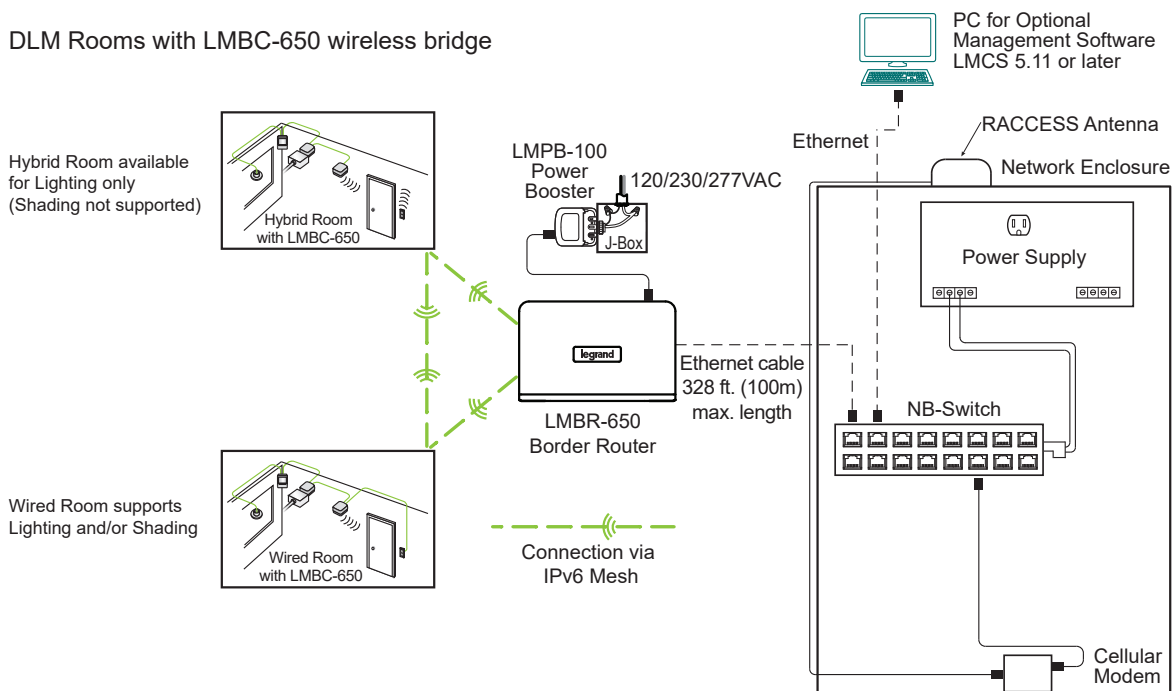

IMPORTANT INSTALLATION INFORMATION

To ensure a successful installation and startup of a wireless system, the following steps must be taken by the installing contractor. **Failure to document all device address and locations may delay completion of startup and result in additional startup charges.**

Key Requirement: Document **every** Device's MAC Address (at least the last 4 alphanumeric characters). An additional MAC address label is included for the installer to use on a floor plan map. The last four characters are repeated in a larger font, in bold. Keep this document so that the commissioning tech has access at a later date.



Examples of labels

COMMISSIONING AND CONFIGURATION

Certified Startup Technician Information

Initial Wireless Operation

1. At power on, led indicators on front of device will begin to illuminate.
2. Upon first use, the border router is configured with default network settings. During this initial state, the wireless network is ready to be commissioned by a Wattstopper authorized field technician.
3. Commissioning of the system is completed using the latest version of the DLM Computer software tool (LMCS-100). For the latest version of LMCS visit <http://www.legrand.us/wattstopper/digital-lighting-management/configuration-controls/dlm-computer-interface-tools-and-software.aspx>
4. Using LMCS, authorized startup technicians will discover all border routers and then provision the network.
5. During the provisioning process, wireless encryption keys and Network ID will be updated.
6. Final steps are to configure DLM parameters as needed.

LMBR-650 LED Indicators

LED	Flashing	Solid	Off
Green	Processor boot up SUCCESS	Processor boot up SUCCESS	Processor boot up ERROR
Orange		Off line data logging SUCCESS	Off line data logging ERROR
Blue	LAN Port set to 192.168.5.241 (default IP Address)	LAN Port set to Static IP	LAN Port set to DHCP
White	Networked (LMBR talking to other devices)	Searching for a network	
Red		Power connection SUCCESS	Power connection ERROR

NOTE: Blue LED behavior applies to LMBR-650 with firmware version 10.147 or later

WIRELESS NETWORK AND SECURITY SETTINGS

All communication is encrypted via AES 128bit encryption. Each border router ships with a unique MAC address printed on the product label. This address is used to identify the border router when configuring with LMCS.

During system startup and commissioning, the LMCS software is used to connect and set network settings by changing from default to unique settings that are shared by all devices connected to the border router.

Network and security settings can be reset to factory defaults and reconfigured. Contact support for assistance as needed.

SWITCHING BETWEEN DHCP & STATIC IP

Configuring LAN Port IP Settings

The LMBR-650 wired LAN port supports the following IP address configuration methods:

- **Self Addressing Static IP** address configured by the LMBR-650
- **Automatically assigned IP** address from a DHCP server
- **Manually assigned Static IP** address configured with LMCS

The Self Addressing feature is enabled by default on all LMBR-650 with firmware version 10.147 or later and is the easiest way to set a unique static IP address on an uncommissioned LMBR using the following process:

1. Connect the **factory default/uncommissioned** LMBR-650 to a wired local area network and power on the LMBR-650.
1. Self Addressing will select and assign an available Static IP address between 192.168.5.189 and 192.168.5. 240.
2. Once Self Addressing is complete the Blue LED status will be solid ON. If Self Addressing fails, the Blue LED status will be flashing and the LMBR will have a default IP Address of 192.168.5.241.

NOTE: Self Addressing requires firmware version 10.147 or later and is only active when the LMBR-650 is in a **factory default/uncommissioned** state. Prior to 10.147, DHCP was the default LAN Port setting. In all LMBR-650s with 10.147 and later the default LAN Port setting is Static IP. Upgrading a **commissioned** LMBR to 10.147 or later will not change any IP Settings.

Switching between Static IP and DHCP or resetting the LMBR-650

The border router has a recessed button located near the network and USB ports. You will need a paper clip to press the button.

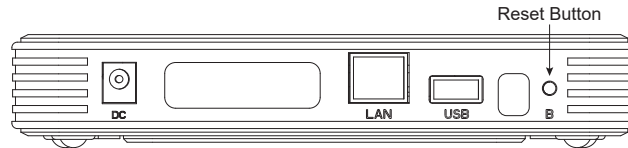

The reset button allows you to manually set the LMBR-650 LAN port to DHCP or Static IP, or to reset the router to the default Network and Channel. To access these functions, first enter “Config” mode by pressing and holding the button for 3 seconds. After three seconds, the Blue LED turns solid and the White LED will begin to blink (the Red LED always remains solid while the unit is powered). Release the button. At this point the following options are available, by pressing and releasing the B button to cycle through the choices: If you cycle past your choice, keep pressing until that option is selected again. The White button always remains blinking while you cycle through the options.

- Option 1: When you first enter Config mode, the Blue LED will display solid. This option will set the router to DHCP.
- Option 2: Press and release the B button once to set the router to Static IP. The Orange LED will display solid and the Blue LED will Turn Off to indicate this choice.

NOTE: If you change to a static IP using this method, the IP address will be 195.168.5.241. It is also possible to switch the LMBR-650 to a static IP address using LMCS-100 software. The LMCS method allows you to choose the specific IP address.

- Option 3: Press and release the B button a second time to exit “Config” Mode without making any changes. The Green LED will display solid and the Orange LED will Turn Off to indicate this choice.
- Option 4: Press and release the B button a fourth time to completely reset the router. The Blue, Yellow, and Green LEDs will all display solid to indicate this choice. This will set the Network ID and Channel to the default values and return it to an uncommissioned state. The Self Addressing Static IP mode will be re-enabled and it will once again select and assign a IP address. In addition to returning the LMBR-650 to its default setting, this will delete any security keys downloaded to the LMBR-650 if it was connected to a site when running discovery on LMCS-100 software. For more details, see the following information on resetting or replacing an LMBR-650.

If you select Options 1 through 3, then press and hold the button for 3 seconds to commit to the choice. If you select Option 4, press and hold the button for 15 seconds. While holding the button, for the first three seconds the white LED will continue blinking and then all the LEDs will start blinking. After 15 seconds, the LEDs will briefly blink more quickly indicating the LMBR-650 will be reset. Release the button. The LMBR-650 will then reboot. The rebooting process will take several seconds

NOTE: If you are on option 4 and press and release the B button without holding it for the 15 seconds, the unit will cycle back to choice 1, as indicated by the LEDs.

REPLACING OR RESETTING AN LMBR-650

NOTE: Resetting an LMBR-650 that has already been discovered using LMCS-100 software has important ramifications, described below. Wattstopper recommends that you contact support before proceeding with a reset of an already commissioned LMBR-650.

If replacing or resetting an LMBR in a site with only one LMBR, you will have to:

1. Create a brand new site, because this is the only way to get the security keys loaded into the LMBR.
2. Reset ALL devices connected to that LMBR.
3. Run the discovery process exactly like you would with a new installation.
4. Since you will have a new site file, you will have to reprogram all DLM parameters for the various devices.

If replacing or resetting an LMBR in a site with more than one LMBR, you do not have to create a new site. However you will need to:

1. Open the LMCS site file and delete the LMBR from the tree. If it was the Primary LMBR, one of the others will automatically become the primary.
2. Reset ALL devices that are assigned to the network of the LMBR being replaced or reset (all other devices assigned to other LMBRs do NOT need to be reset).
3. Run through the discovery process again to add the new/reset LMBR and then rediscover the devices that will connect to that LMBR's network. Once the devices have been reassigned to the network, there is no need to do any room assignment since they already exist in the room in the project file. However, you will still need to re-pair devices by highlighting each room in the three and clicking the Wireless Device Pairing button in LMCS.

NOTE: Keep in mind that if the old or reset LMBR was set to a static IP address, you will need to add a router back into the network in order to communicate with the new or reset LMBR, since it will be set to DHCP. Be sure to set the LMBR-650 to static IP before completing the process. It is not necessary to use the same static IP address as was used previously.

Reset via LMCS:

Once an LMBR has been commissioned within LMCS, it can be reset through LMCS. From the Networks Tab, expand the tree, and highlight the LMBR in the tree. Click the **Factory Reset** button in the information section. As with a reset via button press on the unit, you will then need to rediscover the LMBR in LMCS and return it to its previous Network ID and Channel in order to reestablish communication with the devices that are on that network.

FCC REGULATORY STATEMENTS

The design of LMBR-650 complies with FCC and IC safety levels of radio frequency (RF) exposure for Mobile devices.

This device is only authorized for use in a mobile application. At least 20 cm of separation distance between the LMBR-650 device and the user's body must be maintained at all times.

CAUTION: Any changes or modifications not expressly approved by The Watt Stopper Inc. void the user's authority to operate the equipment.

This equipment has been tested and found to comply with the limits for a Class A digital device, pursuant to part 15 of the FCC Rules. These limits are designed to provide reasonable protection against harmful interference when the equipment is operated in a commercial environment. This equipment generates, uses, and can radiate radio frequency energy and, if not installed and used in accordance with the instruction manual, may cause harmful interference to radio communications. Operation of this equipment in a residential area is likely to cause harmful interference in which case the user will be required to correct the interference at his own expense.

Contains FCC ID: Q4B-LMBR-600. The enclosed device complies with Part 15 of the FCC Rules. Operation is subject to the following two conditions: 1) this device may not cause harmful interference, and 2) this device must accept any interference received, including interference that may cause undesired operation.

IC REGULATORY STATEMENTS

Contains IC: 20256-BR1 This device complies with Industry Canada license-exempt RSS standard(s). Operation is subject to the following two conditions: 1) this device may not cause interference, and 2) this device must accept any interference, including interference that may cause undesired operation of the device.

In order to enhance the security of our products, Legrand ships its products with all insecure ports closed and insecure protocols disabled. You are free to configure your device as needed, but in doing so note that you may be decreasing the security of your device and any information contained in the device. As you modify the device's default settings, keep in mind how this may impact the security of the device and your network. In addition, you should use caution in connecting your device to the Internet, especially if you have altered the default security settings. If you have any questions or concerns about how your modifications of the device may affect its security, please contact the Legrand customer service team at 1-800-879-8585 / <https://www.legrand.us/support/wattstopper.aspx>

NOTE: No rights or licenses under patents owned or controlled by third parties, express or implied, are granted to use third-party devices in combination with these products in a wireless mesh network, or to use third-party services to access, monitor or control these products in a wireless mesh network via the internet or another external wide area network. Separate license rights may need to be obtained from such third parties for such devices, combinations and services.

WARRANTY INFORMATION

Wattstopper warrants its products to be free of defects in materials and workmanship for a period of five (5) years. There are no obligations or liabilities on the part of Wattstopper for consequential damages arising out of, or in connection with, the use or performance of this product or other indirect damages with respect to loss of property, revenue or profit, or cost of removal, installation or reinstallation.

INFORMATIONS RELATIVES À LA GARANTIE

Wattstopper garantit que ses produits sont exempts de défauts de matériaux et de fabrication pour une période de cinq (5) ans. Wattstopper ne peut être tenu responsable de tout dommage consécutif causé par ou lié à l'utilisation ou à la performance de ce produit ou tout autre dommage indirect lié à la perte de propriété, de revenus, ou de profits, ou aux coûts d'enlèvement, d'installation ou de réinstallation.

INFORMACIÓN DE LA GARANTÍA

Wattstopper garantiza que sus productos están libres de defectos en materiales y mano de obra por un período de cinco (5) años. No existen obligaciones ni responsabilidades por parte de Wattstopper por daños consecuentes que se deriven o estén relacionados con el uso o el rendimiento de este producto u otros daños indirectos con respecto a la pérdida de propiedad, renta o ganancias, o al costo de extracción, instalación o reinstalación.