

EM4-200S12DC

Class 2 Magnetic

Outdoor Black Powder Coated Steel Enclosure

Multi Circuit: **12VDC**

Total Wattage: **200W max**

Input Voltage: **120V 60Hz**



Conforms to UL STD. 2108
Certified to CSA
STD. C22.2 No 250.0
model EM3

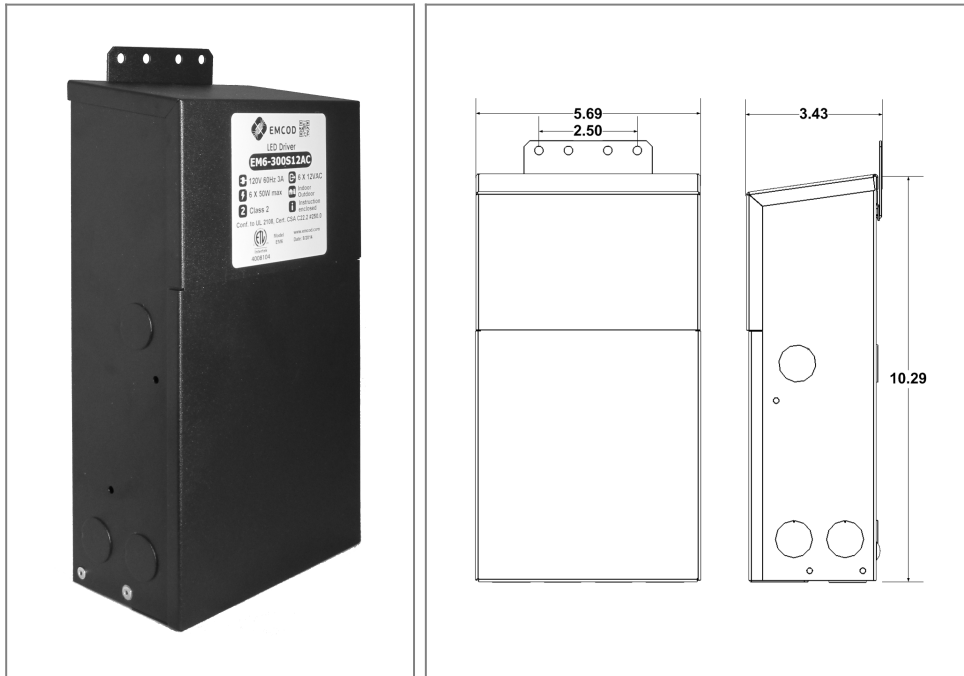

Transformer

Temperature class B(130°C)

Two section bobbin completely separated primary and secondary windings

Input leads are 18AWG 600V

Output leads: Terminal Block

Leads max. operational temperature is 105°C

Thermal manually reset primary breaker 3A

Thermal manually reset secondary breaker 5A per circuit

Housing

The actual transformer 200W is encapsulated in the enclosure

The enclosure is Black Powder Coated Steel, NEMA 3R rated

Wiring compartment has 13 knockouts sizes for 3/8 inch screw cable connectors

Enclosure Temperature does not exceed 75°C at 45°C ambient and fully loaded

Dimensions (inch): H = 10.29, W = 5.69, D = 3.43

Weight (LBs): 0.92

Electrical Parameters

Input Voltage: **120V 60Hz**

Max. input current at full load: **2A**

Output voltage without load: **12.8VDC**

Output voltage fully loaded: **11.8VDC**

Max. Total Wattage: **200W** Max. per circuit: **50W**

Max. Output Current: **4.1A** per circuit.

Efficiency: **90%**

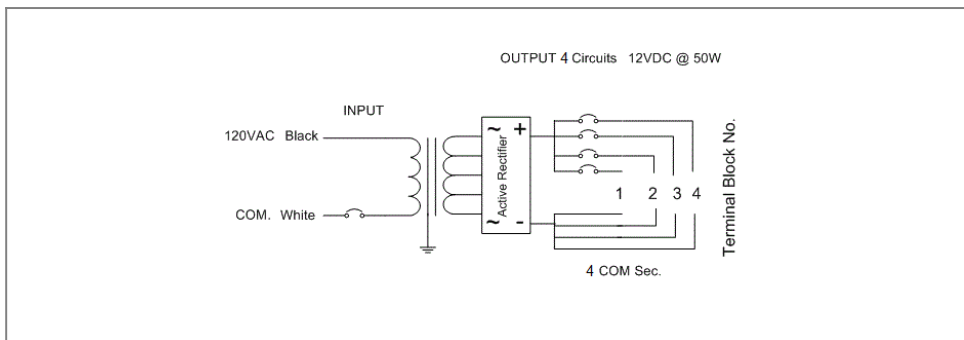

Mailing Address: 6925 Eton Ave. Canoga Park, CA 91303 Tech support: Arik Nirenberg phone: 818-904-3309 cellphone: 818-269-4091
Fax: 818 904 3327 info@emcod.com techsupport@emcod.com