



SENSORWORX®

WIRELESS REMOTE DUAL DIMMER/SWITCH

BATTERY POWERED

OVERVIEW

The **SENSORWORX** wireless dual dimmer and switch provides remote manual operation of two wirelessly controlled lighting zones. These attractive single gang wide wall stations are powered by a single battery and require just a few seconds per device to wirelessly configure. They can be easily linked to one or more wireless load controllers (such as the **SWX-851** wireless wall switch, **SWX-950** series wireless power pack, or **SWX-874** phase dimmer). Additionally, these devices can be utilized with other wireless wall stations to provide dimming and switching control from multiple locations.

FEATURES

- Dimming & On/Off Control of Two Wireless Zones in a Single Gang Device
- Pairs in Seconds with Wireless Load Controllers
- 10 Year Battery Life Design
- Decorator Style Fits Common Wall Plates (not included)
- Matches Styling of other SWX Sensors & Wired Wall Stations
- Enables Multiway Switching & Dimming (e.g., 3-way, 4-way)

SPECIFICATIONS

ELECTRICAL & WIRELESS

BATTERY TYPE

Requires one CR123(A) Lithium Battery (provided)

BATTERY LIFE

Designed for 10 Year Life
Non-Volatile Memory (saves all settings regardless of battery state)
Blink Warning @10% Life

RANGE

80' line of site w/o obstruction (walls)
40' with obstruction (walls/floors)

FREQUENCY

915 MHz ISM Band

WIRELESS LINKING

Simple 3 sec. Push Button Process

SECURITY

All Wireless Data is Encrypted

ENVIRONMENTAL

OPERATING TEMP

32°F to 122°F (0°C to 50°C) - Standard
-40° F/C (with **-HE** Option)

RELATIVE HUMIDITY

0-95% Non-Condensing,
Indoor Use Only

PHYSICAL

SIZE

2.74"H x 1.68"W x 1.39"D
(6.96 x 4.27 x 3.53 cm)
Fits Decorator Switch Plate Opening

WEIGHT

2.5 oz

MOUNTING

Single Gang Switch Box

CODE COMPLIANCE

These switches can be used to meet ASHRAE 90.1, IECC, & Title 24 energy code requirements.



ORDERING INFO

SAMPLE MODEL # SWX-854-2P-B-WH

MODEL & DESCRIPTION	COLOR *	OPTIONS
SWX-852-2P-B Wireless Remote 2-Zone On/Off Wall Station, Battery Powered	White - WH Ivory - IV Black - BK	Light Almond - LA Gray - GY Red - RD Low Temp. / - HE High Humidity *Wall plate not included
SWX-854-2P-B Wireless Remote 2-Zone Dimmer Wall Station, Battery Powered		
ACCESSORY PART #	COLOR	PACKAGE COUNT
SWX-199 Single Gang Wall Plate	White - WH Ivory - IV Black - BK	Light Almond - LA Gray - GY Red - RD 10 Pack - J10

APPLICATIONS

Adding a dual zone wireless remote wall switch to a room controlled by a two wireless power packs (**SWX-950**) and a wireless sensor (e.g. **SWX-201-B**) enables code compliant vacancy (manual on) operation of each zone. When linked with two wireless dimming power packs (**SWX-950-D2**), a dual zone remote wireless dimmer is perfect for providing raise/lower control of each zone.

The 2-zone switch (**SWX-852-2P-B**) and the 2-zone dimmer (**SWX-854-2P-B**) pair to each zone independently.

Additional remote dimmers & switches can be linked, enabling user control from multiple locations (3-way & multi-way). Linking a remote wireless switch to a wireless wall switch load controller (**SWX-851**) or phase dimming load controller (**SWX-874**) enables 3-way user control as well.

- Classrooms
- Open Areas
- Conference Rooms
- Hallways
- Small Offices
- Copy Rooms
- Private Restrooms
- Break Rooms

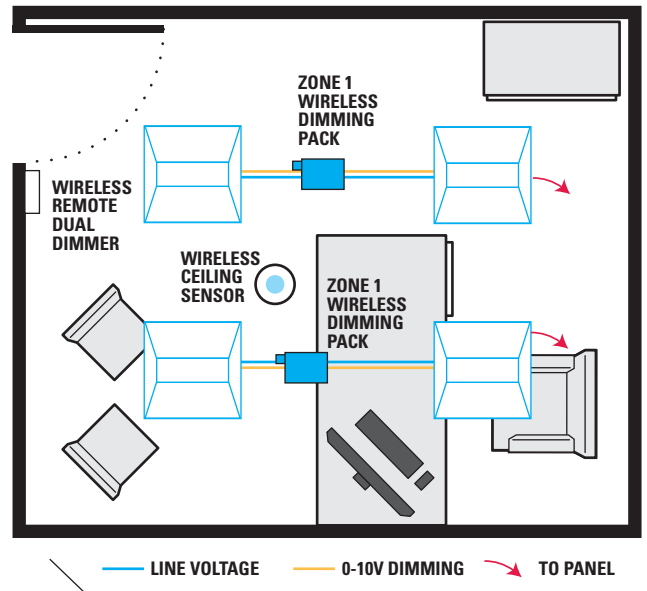

OPERATION NOTES

- Wireless remote switches and dimmers only transmit when a button is being pressed.
- The unit's LED (top or bottom) that is associated with the zone being controlled will light blue when a button is pressed.
- The dim up and dim down buttons may be held down to increase dimming rate.
- There are always 20 equal steps of dim level (voltage) adjustment from high trim to low trim (or reverse) when using a **SWX-854-2P-B** wireless remote dimmer.

INSTALLATION

- Designed to mount in 1-gang wall box with 3.28" hole spacing.
- Units can also share multiple gang wall boxes with other devices.

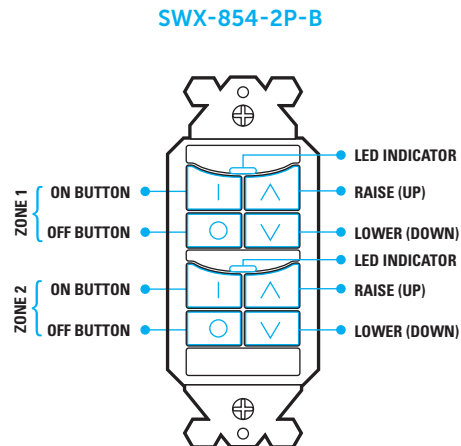
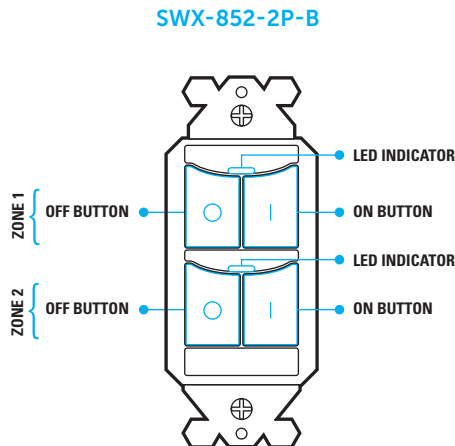

BATTERY INFORMATION

- The switch/dimmer runs on one CR123(A) Lithium Battery (included).
- Install battery prior to mounting. Polarity is indicated on the battery compartment door.
- If the unit's battery life reaches 10%, the LED will no longer light up after every button press.
- Replacement batteries are available at most retailers or home centers where batteries are sold or from **SENSORWORX**.

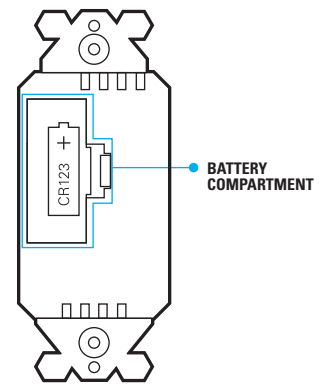

COMPATIBLE WIRELESS DEVICES

The below chart lists the devices that can be used in a **SENSORWORX** wireless application. Note that sensors and remote switch & dimmer devices are transmit only devices and therefore must be linked to a load controller for switching or dimming of lighting.

MODEL #	DESCRIPTION	WIRELESS TYPE	POWER TYPE
SWX-201-B	Small Motion 360° Sensor, PIR	Transmit	Battery
SWX-211-B	Small Motion 360° Sensor, PIR w/ Integrated Daylight Harvesting Photocell	Transmit	Battery
SWX-221-B	Dual Technology Sensor (PIR/Acoustic), Small Motion 360°	Transmit	Battery
SWX-401-B	Wide View Sensor, PIR	Transmit	Battery
SWX-421-B	Dual Technology (PIR/Acoustic) Wide View Sensor	Transmit	Battery
SWX-402-B	Long Range Hallway Sensor, PIR	Transmit	Battery
SWX-250-B	Daylight Harvesting & On/Off Photocell	Transmit	Battery
SWX-851-xx	Wall Switch Load Controller, No Neutral Required, <xx = color>	Transmit & Receive	120-277 VAC
SWX-852-B-xx	Remote Switch (On/Off), <xx = color>	Transmit	Battery
SWX-852-2-xx	Remote Line Powered Switch (On/Off), <xx = color>	Transmit	120-277 VAC
SWX-854-B-xx	Remote Dimming Switch (On/Off, Raise/Lower), <xx = color>	Transmit	Battery
SWX-854-2-xx	Remote Line Powered Dimming Switch (On/Off, Raise/Lower), <xx = color>	Transmit	120-277 VAC
SWX-854-4S-B-xx	Remote 4-Scene + Dimmer Wall Station, <xx = color>	Transmit	Battery
SWX-874-ELV-xx	Phase Dimming Load Controller - Reverse (default) or Forward Phase, <xx = color>	Transmit & Receive	120 VAC
SWX-950	Power Pack Load Controller, 20A	Transmit & Receive	120/277 VAC
SWX-951-D1	Fixture Controller, 1A@, 0-10V Dimming	Transmit & Receive	120-277 VAC
SWX-950-D2 (SWX-950-D1)	Power Pack Load Controller, 20A, 0-10V Class 2 Dimming (Class 1 model)	Transmit & Receive	120/277 VAC
SWX-950-AX	Hybrid Wireless/Wired Power Pack Load Controller, 20A	Transmit & Receive	120/277 VAC
SWX-950-AX-D2	Hybrid Wireless/Wired Power Pack Load Controller, 20A, 0-10V Dimming (Class 2)	Transmit & Receive	120/277 VAC
SWX-970-D2 (SWX-970-D1)	Advanced Load Controller w/ App, 16A,0-10V Class 2 Dimming (Class 1 model)	Transmit & Receive	120-277 VAC

WIRELESS PAIRING

Pairing a remote dimmer/switch with a wireless wall switch load controller or power pack load controller is quickly done via the following procedure:

1. Enter pairing mode by holding down the wireless load controller's button for 3 seconds until the LED starts alternating white then blue.
2. At the battery powered remote dimmer/switch, hold down the ON button for 3 seconds until the LED starts alternating white then blue. Releasing will pair the device with the controller in pairing mode (see note 1 below). The lights will toggle once as confirmation.
3. If additional remote dimmers or switches need to be linked, repeat step 2.
4. When all devices have been paired, close pairing mode on the wireless load controller by pressing the button 1 time. Pairing will also be automatically closed after 15 minutes of no new devices being linked.

Note 1: When in pairing mode, the alternating LED colors on the wireless load controller will periodically pause and blink out the total number of paired devices. There will be no blinks during the pause until the first device is linked.

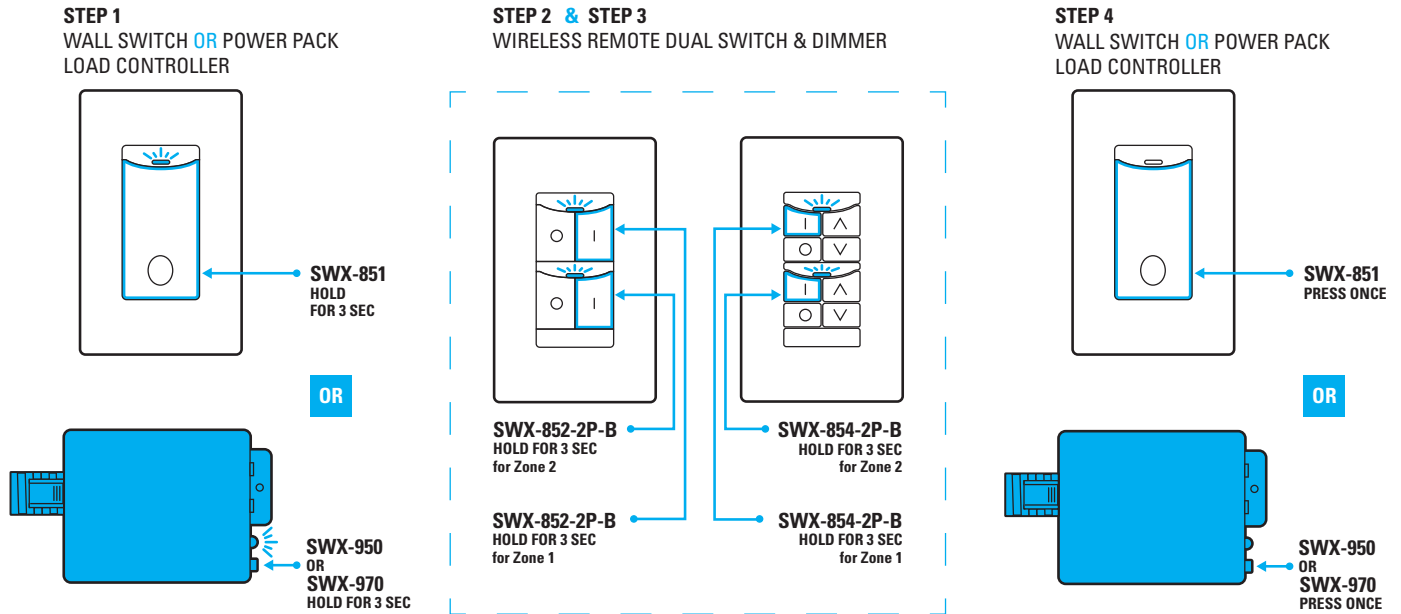

FCC INFORMATION

This device complies with Part 15 of the FCC Rules. Operation is subject to the following conditions:

1. This device may not cause harmful interference, and
2. This device must accept any interference received, including interference that may cause undesired operation

Changes and Modifications not expressly approved by BLP Technologies can void your authority to operate this equipment under Federal Communications Commission's rules.

In order to comply with FCC/ISED RF Exposure requirements, this device must be installed to provide at least 20 cm separation from the human body at all times.

This equipment has been tested and found to comply with the limits for a Class B digital device, pursuant to Part 15 of the FCC Rules. These limits are designed to provide reasonable protection against harmful interference in a residential installation. This equipment generates uses and can radiate radio frequency energy and, if not installed and used in accordance with the instructions, may cause harmful interference to radio communications. However, there is no guarantee that interference will not occur in a particular installation. If this equipment does cause harmful interference to radio or television reception, which can be determined by turning the equipment off and on, the user is encouraged to try to correct the interference by one of the following measures:

- Reorient or relocate the receiving antenna.
- Increase the separation between the equipment and receiver.
- Connect the equipment into an outlet on a circuit different from that to which the receiver is connected.
- Consult the dealer or an experienced radio/TV technician for help

ISED CANADA INFORMATION

This device contains licence-exempt transmitter(s)/receiver(s) that comply with Innovation, Science and Economic Development Canada's licence-exempt RSS(s). Operation is subject to the following two conditions:

1. This device may not cause interference.
2. This device must accept any interference, including interference that may cause undesired operation of the device.

In order to comply with FCC/ISED RF Exposure requirements, this device must be installed to provide at least 20 cm separation from the human body at all times.

L'émetteur/récepteur exempt de licence contenu dans le présent appareil est conforme aux CNR d'Innovation, Sciences et Développement économique Canada applicables aux appareils radio exempts de licence. L'exploitation est autorisée aux deux conditions suivantes :

1. L'appareil ne doit pas produire de brouillage;
2. L'appareil doit accepter tout brouillage radioélectrique subi, même si le brouillage est susceptible d'en compromettre le fonctionnement.
3. Afin de se conformer aux exigences d'exposition RF FCC / ISED, cet appareil doit être installé pour fournir au moins 20 cm de séparation du corps humain en tout temps

