

The Exitronix RS2 Series combines LED performance and dependability with a rugged 20 gauge steel enclosure. This corrosion-resistant, value-driven emergency unit features fully-adjustable LED lamp heads and easy installation.

Model: _____ Date: _____
 Accessories: _____
 Job Name: _____ Type: _____

FEATURES & BENEFITS

- High impact, injection molded, thermoplastic LED lamp heads
- 1.5W (12 LEDs x .125 watt) per lamp head
- Enclosure constructed of rugged 20 gauge steel
- Remote capacity of 20W, compatible with **MLED** LED remote lamps
- Extended run time (up to 8 hours without remotes)
- Meets City of New York Emergency Code requirements

SPECIFICATIONS

Illumination: Two top mounted, fully adjustable, high intensity lamp heads with high performance, chrome plated, metallized reflector and plastic lens

Housing: Rugged 20 gauge steel with powder coated finish

Input: 120/277VAC Dual primary, 60Hz

Battery: Maintenance-free sealed lead calcium battery

Operating Temp: 20°C to 50°C (68°F to 122°F)

Run Time: 90 minute emergency run time, 24 hour recharge time

Electrical: Low voltage disconnect eliminates deep discharge

Mounting: Shelf mount or universal mounting pattern provided for wall mount; knockouts for top or side conduit entry

Finishes: Black or White

Certifications: UL 924 Listed for Damp Locations, Meets NFPA 101 Life Safety Code, NEC, OSHA. Meets City of New York Emergency Code requirements

Warranty: Any component that fails due to a manufacturing defect is guaranteed for five years with a separate five year prorated warranty on the battery. The warranty does not cover physical damage, abuse or instances of uncontrollable natural forces. See the full Exitronix warranty document for detailed information and product registration instructions. (Terms and Conditions apply)

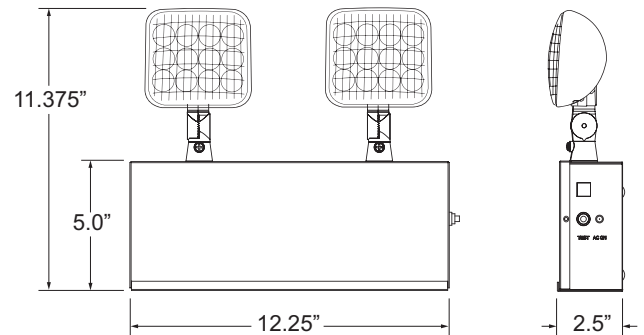

ORDERING INFORMATION Example: RS2-6-27-WH

Series	Battery	Wattage	Finish	Accessories ¹ (Field Installed)
RS2	6 = 6 Volt Lead Calcium	27 = 27 Watts	BL = Black WH = White	WG-S = Wire Guard (Back Mount) XG-PS = Poly Guard (Back Mount) MLED1-W = Indoor Single Remote White MLED2-W = Indoor Double Remote White MLED1-B = Indoor Single Remote Black MLED2-B = Indoor Double Remote Black MLED1-G-WP = Outdoor Single Remote Gray MLED2-G-WP = Outdoor Double Remote Gray MLED1-B-WP = Outdoor Single Remote Black MLED2-B-WP = Outdoor Double Remote Black
Notes				
¹ Order as separate line item				

ULTIMATE PERFORMANCE. UNPARALLELED VALUE.

CONSTRUCTION

The RS2 series is die-formed 20 gauge steel housing with epoxy powder coat finish. Finish is available in White or Black. Universal J-box mounting pattern provided for simple installation. Knockouts are provided on top, back, and sides for easy wire entry. Can also be shelf mounted - ordered separately.

Lamp heads are constructed of high impact thermoplastic in a color matching the finish of the enclosure. The fully adjustable lamp heads feature a nique twist locking collar that securely holds the lens and facilitates quick and easy re-lamping.

ILLUMINATION

Two top mounted, fully adjustable, high intensity lamp heads with high performance, chrome plated, metallized reflector and plastic lens delivers 1.5 watts (12 LEDs x .125 watt) per lamp head to the path of egress. Up to 20 watts of remote capacity is available to provide additional illumination or extended run time. Runs up to 8 hours without any remote heads.

ELECTRICAL

Input

Dual-voltage input 120 or 277VAC @ 60Hz. The RSB is configured with a fully automatic, high-efficiency two stage charger providing precise float voltage control. The internal solid-state transfer switch automatically connects the internal battery to the LED lamp heads for a minimum 90 minutes of emergency illumination. Charger status is easily determined via a dual diagnostic LED display.

SAMPLE PHOTOMETRICS - 3' PATH OF EGRESS

Using multiple RS2 units mounted at a typical 7.5' height delivers 18' on-center spacing with a 3' wide path of egress using 80/50/20 reflectances.

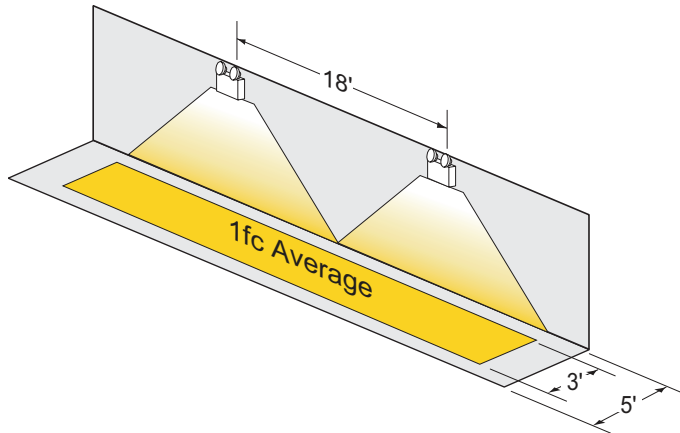

Sealed Lead Calcium Battery

Exitronix sealed lead calcium batteries are maintenance-free.

Emergency

The RS2 series emergency unit will operate for a minimum of 90 minutes during a loss of power with a 24 hour maximum recharge time for the battery.

Low Voltage Disconnect

When the battery's terminal voltage falls below predetermined levels, a low voltage circuit disconnects the emergency lighting load. The disconnect remains in effect until normal power is restored, preventing deep battery discharge and improving the life of the battery. The disconnect will also automatically reconnect the load circuit once the battery voltage returns to a normal value after charging.

Test Button

Our easily located test button allows for manual verification of proper operation of the transfer circuit and emergency lamps.

CONFORMANCE TO CODES & STANDARDS

The RS2 Series is UL 924 Listed for Damp Locations and meets or exceeds the following: NEC requirements, OSHA and NFPA 101. Meets City of New York Emergency Code requirements.

SAMPLE PHOTOMETRICS - 6' PATH OF EGRESS

Using multiple RS2 units mounted at a typical 7.5' height delivers 16' on-center spacing with a 6' wide path of egress using 80/50/20 reflectances.

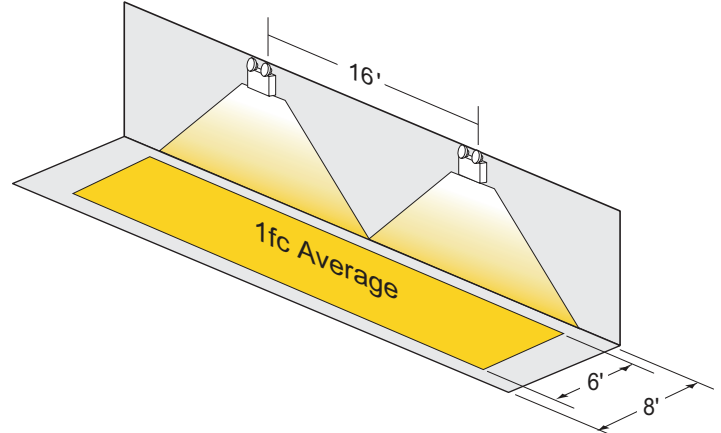

ULTIMATE PERFORMANCE. UNPARALLELED VALUE.