

Liteline RECESSED LIGHTING • LUMINAIRE ENCASTRE

SHADE KIT FOR LED PANEL LIGHTS

IMPORTANT: Read all instructions before installing fixtures. Retain for future reference. Suitable for continuous row mounting.

SAFETY: For your safety, this fixture must be wired in accordance to local electrical codes and ordinances. All work should be done by a qualified electrician.

WARNING: Make certain power is OFF from the electrical panel before starting installation or attempting any maintenance. Indoor installation only.

INSTALLATION INSTRUCTIONS FOR SURFACE:

1. Release two countersunk screws from SHADE frame. Remove the mounting bracket [Fig. 1].
2. Install the mounting bracket on the ceiling (hardware provided by others) [Fig. 2].
3. Connect aircraft cable to secure the fixture to the mounting bracket [Fig. 3].
4. ELECTRICAL CONNECTIONS:
 MAXIMUM OF FOUR 12 AWG BRANCH CIRCUIT CONDUCTOR SUITABLE FOR 90°C PERMITTED IN BOX (2 WIRES IN AND 2 WIRES OUT). NOT SUITABLE FOR THROUGH-WIRING. ALL CONDUCTORS MUST BE TERMINATED IN THE WIRING COMPARTMENT.
 MAXIMUM OF SIX 14 AWG BRANCH CIRCUIT CONDUCTOR SUITABLE FOR 90°C PERMITTED IN BOX (3 WIRES IN AND 3 WIRES OUT). NOT SUITABLE FOR THROUGH-WIRING. ALL CONDUCTORS MUST BE TERMINATED IN THE WIRING COMPARTMENT.
 - a. Remove the cover on the junction box.
 - b. Bring in a power supply line through one of the knockouts located closest to the input module. Wire connector required (supplied by others).
 - c. Connect the green (or bare copper) wire to the ground port of the input module.
 - d. Connect the white wire to the Neutral (N) port of the input module.
 - e. Connect the black wire to the Live (L) port of the input module.
 - f. Replace the junction box cover back in place.
 - g. Use the selector tabs on the side of the driver/junction box to select wattage (preset to highest wattage) and color temperature.
 - h. Turn the power back on from the main panel.
5. Align the secure pins on SHADE with the mounting bracket and slide the frame in place. Make sure the fixture drops into the groove on the mounting bracket [Fig. 5].
6. Secure two countersunk screws from SHADE frame [Fig. 6].

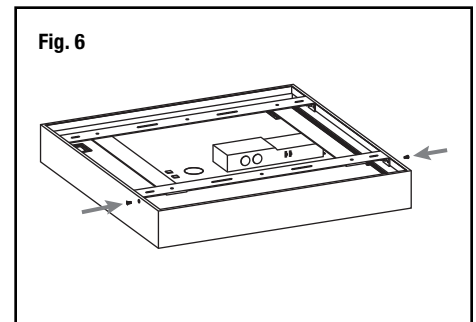
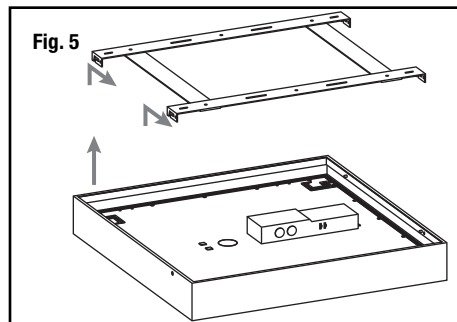
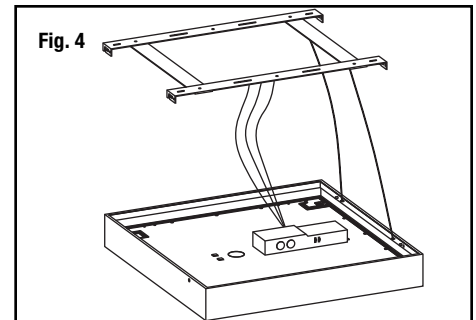
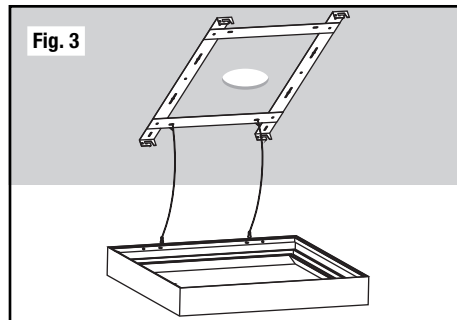
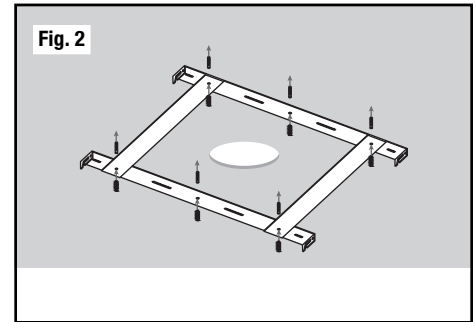
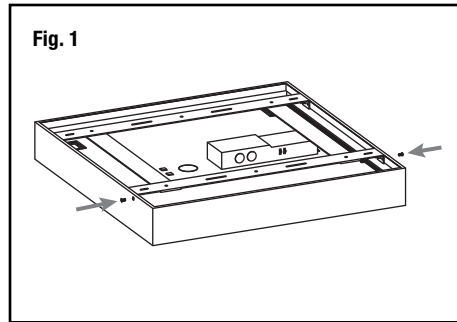

INSTALLATION INSTRUCTIONS FOR PENDANT:

1. Ensure that power has been turned off at the breaker to the junction box where this product is being installed.
2. Install the 4 cable couplers onto the ceiling and secure with screws [Fig. 1]. Refer to table below for ceiling measurements.
3. Place cylindrical end of the aircraft cables through the threaded sleeve and secure onto the cable couplers. [Fig. 2].
4. Place aircraft cable through the mounting bracket and align the fixture by adjusting the aircraft cable lengths and install the stoppers at the end. Fasten the screw on each stopper. Push down on the grip lock pin to allow aircraft cable to back out [Fig. 3].
5. Ensure the SHADE is securely mounted before proceeding to wiring [Fig. 4].
6. All electrical connections within the SHADE have been pre-wired at the factory. Use the included 10-ft electrical wiring to complete the electrical installation to the AC source. Ensure all electrical connections are in accordance to local electrical codes and ordinances. All work should be done by a qualified electrician.

Part No.	Length	Width
SH-P612	7" (178mm)	24 ¹ / ₁₆ " (633mm)
SH-P614	7" (178mm)	48 ¹ / ₁₆ " (1243mm)
SH-P616	7" (178mm)	72 ¹ / ₁₆ " (1852mm)
SH-P11	12 ¹ / ₁₆ " (329mm)	12 ¹ / ₁₆ " (329mm)
SH-P12	12 ¹ / ₁₆ " (329mm)	24 ¹ / ₁₆ " (633mm)
SH-P14	12 ¹ / ₁₆ " (329mm)	48 ¹ / ₁₆ " (1243mm)
SH-P22	24 ¹ / ₁₆ " (633mm)	24 ¹ / ₁₆ " (633mm)
SH-P24	24 ¹ / ₁₆ " (633mm)	48 ¹ / ₁₆ " (1243mm)

