



SENSORWORX®

POWER PACK

INSTALLATION & OPERATION INSTRUCTIONS

CATALOG NUMBERS	DESCRIPTIONS
SWX-900	POWER PACK
SWX-900-AX	POWER PACK WITH AUXILIARY SWITCH INPUT
SWX-910	SECONDARY RELAY PACK
SWX-910-AR	CONTACT CLOSURE PACK
SWX-920	AUXILIARY POWER SUPPLY
SWX-999	LOW VOLTAGE WIRING CHAMBER

ADDITIONAL UNIT OPTIONS
 - **HE:** High Humidity Environment

OVERVIEW

SENSORWORX power packs transform incoming line voltage power to Class 2 low voltage as needed by sensor(s) or other control device(s). Additionally, they switch on/off power to the connected lighting load as directed by the sensors and controls.

FEATURES

- Powers Low Voltage Sensors
- Switches Line Voltage Loads
- Electronically Timed Switching (i.e. Zero Crossing) Ensures Long Relay Life
- Integrated Test/Programming Button
- Optional Snap-On Attachment Provides Chamber for Low Voltage Wire Connections
- Optional Switch Input for Manual On, Hold On, or Hold Off Operations
- Plenum Rated (UL 2043)

INSTALLATION INSTRUCTIONS

MOUNTING INSTRUCTIONS

Power Packs are designed to attach to electrical enclosures with 1/2" knockouts.

INSTALLATION NOTES

- 1 For supply connections, use 14 AWG (90°C) or larger wires. Wire all circuits exiting chase nipple as Class 1 circuits.
- 2 Suitable for plenum use.
- 3 Risk of Electric Shock - More than one disconnect switch may be required to de-energize the equipment before servicing.

SPECIFICATIONS

ELECTRICAL

OPERATING VOLTAGE

120/277 VAC

CLASS 2 OUTPUT RATINGS

18 VDC, 150 mA
 (SWX-900 / SWX-900-AX / SWX-920)
 Connected device power:
 80 mA (SWX-900 / SWX-900-AX)
 150 mA (SWX-920)

LOAD RATINGS

(SWX-900 / SWX-900-AX / SWX-910)
 (relays use zero-cross switching)

20A @ 120 V -
 General Purpose Plug Load

20A @ 120/277 VAC -
 General Purpose, Tungsten, Magnetic Ballast

16A @ 120/277 VAC -
 Electronic Ballast, LED Driver

DC LOAD RATINGS

20A @ 28 VDC (MAX)
 1A @ 5 VDC (MIN)

MOTOR LOAD

1 HP

ENVIRONMENTAL

OPERATING TEMP

32°F to 122°F (0°C to 50°C) - Standard
 -40° F/C (with **-HE** Option)

RELATIVE HUMIDITY

0-95% Non-Condensing,
 Indoor Use Only

ROHS COMPLIANT

PHYSICAL

SIZE

3.00" H x 2.25" W x 1.88" D
 (7.62 cm x 5.72 cm x 4.78 cm)

WEIGHT

6.00 oz.

COLOR

Blue

MOUNTING

1/2" Knockout

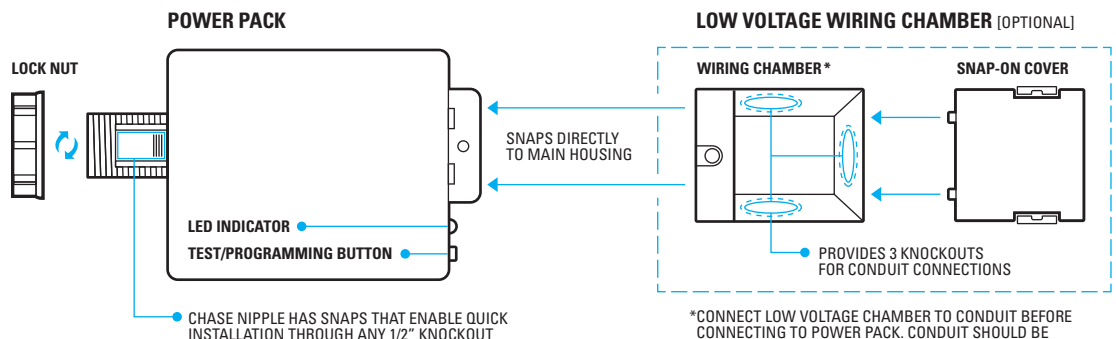

WIRING

STANDARD WIRING

MODEL #: SWX-900

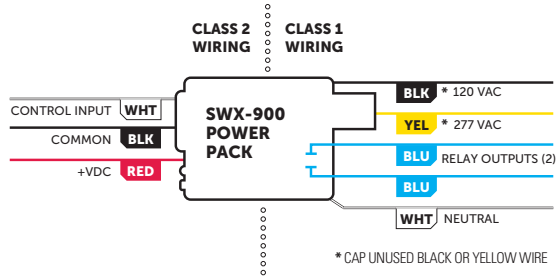

MODEL #: SWX-900-AX

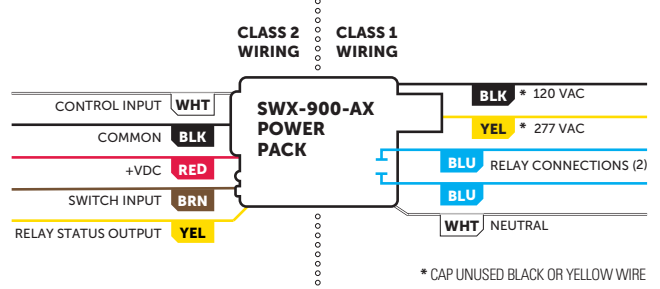

MODEL #: SWX-910

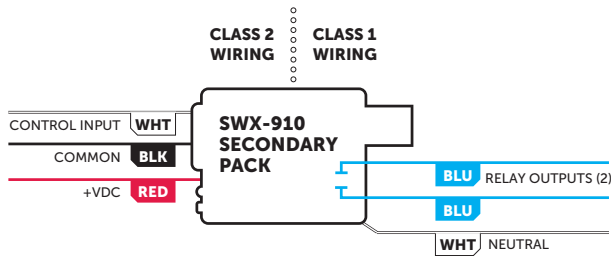

MODEL #: SWX-910-AR

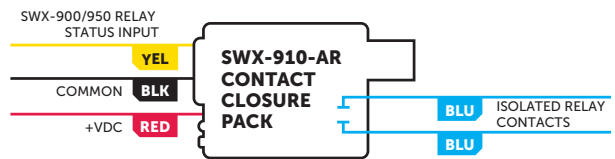

SINGLE SENSOR

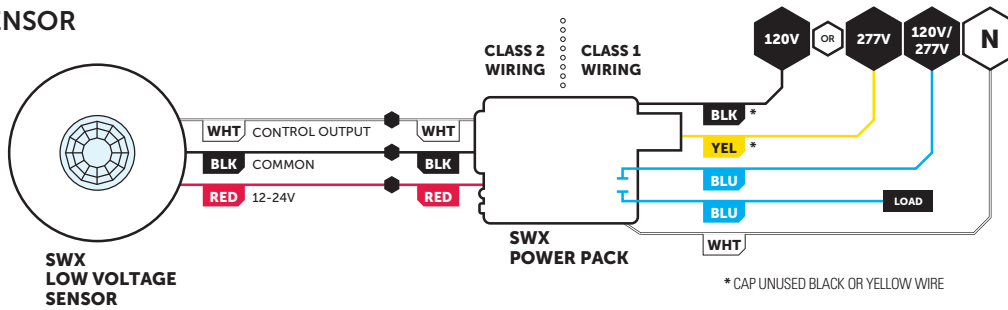

MULTIPLE SENSOR WIRING

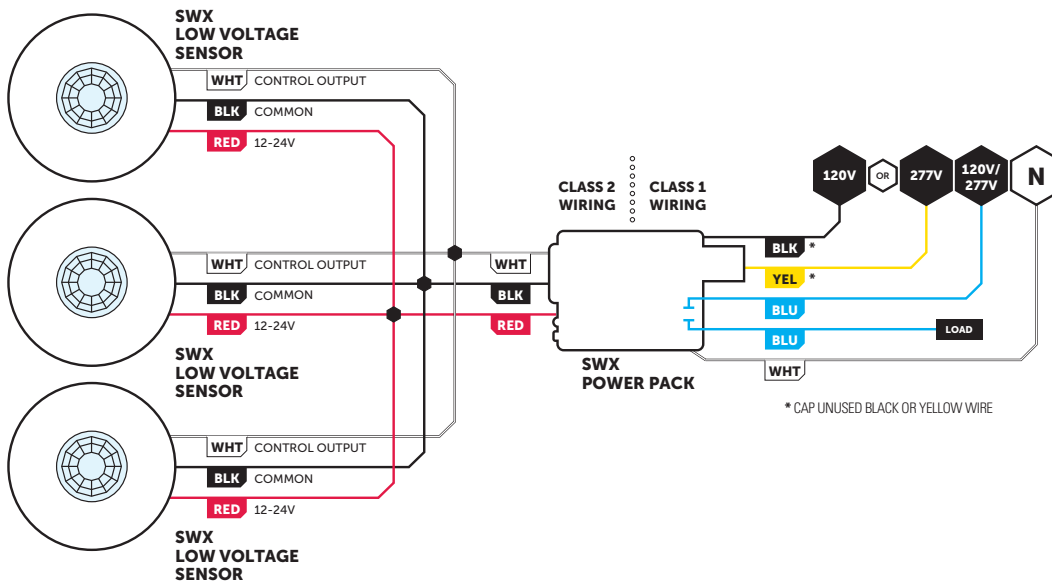

WIRING CONT.

MULTIPLE POWER PACK WIRING COMMON LINE FEEDS

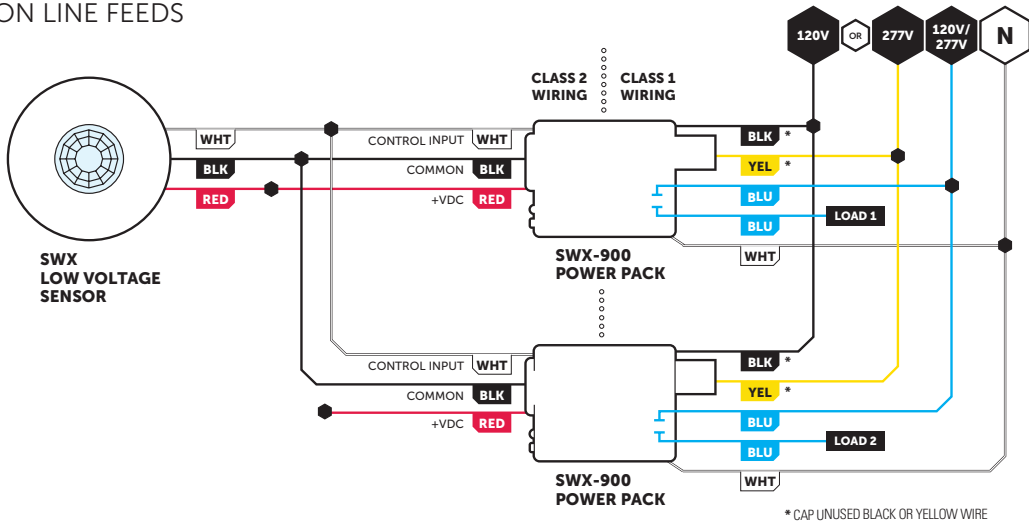

MULTIPLE POWER PACK WIRING SEPARATE LINE FEEDS

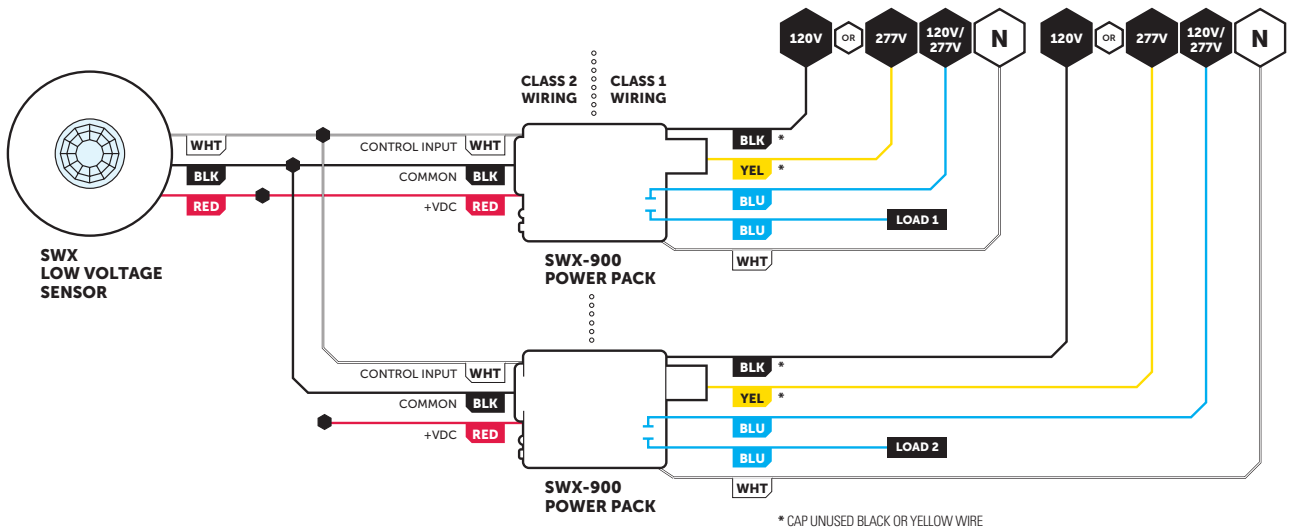

POWER PACK w/ SECONDARY RELAY PACK WIRING

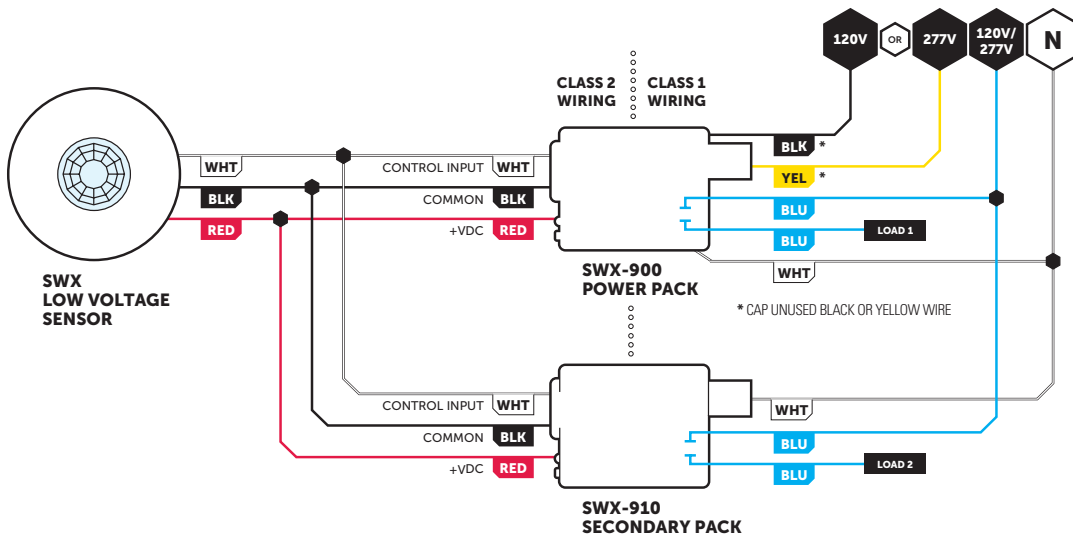

WIRING CONT.

POWER PACK CONNECTED TO SWITCH (requires -AX option)

- Some energy codes require Manual On (also called Vacancy) operation where an occupant is required to initially switch on lighting. The sensor then ensures lights are turned off once the space is unoccupied
- Interfacing momentary switches such as the SWX-801-xx or SWX-803-xx are recommended, however maintained switches can also be utilized
- For momentary switches, the power pack will react on the leading edge of a pulse on the brown input wire
- For maintained switches, any change of state on the brown wire that lasts longer than 0.5 seconds will be read by the power pack as one action
- If no sensor is present, tie power pack low voltage white wire to low voltage red wire

MOMENTARY SWITCH

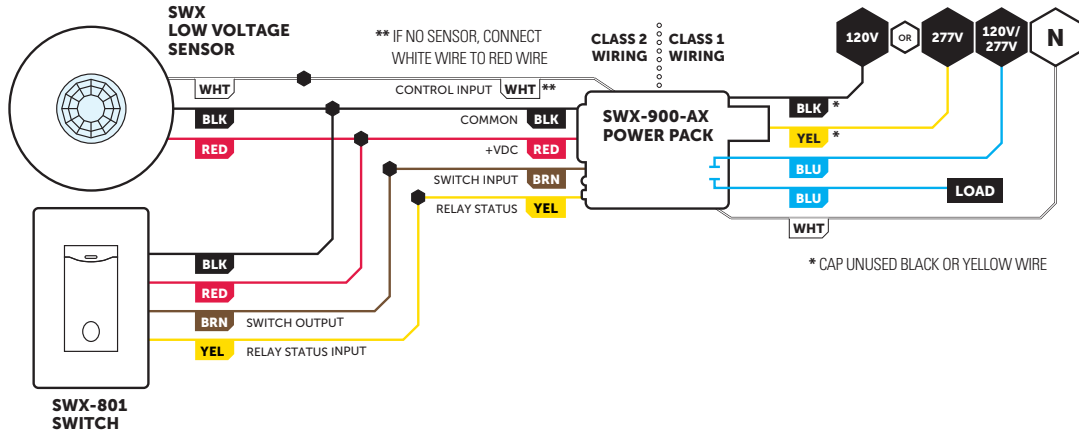

MAINTAINED SWITCH

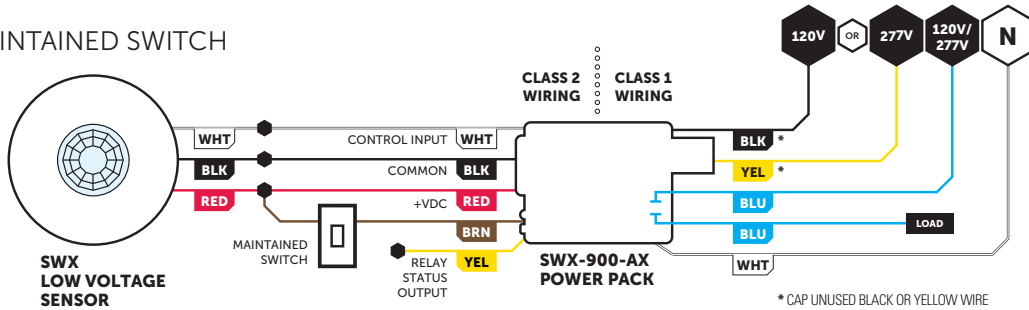

POWER PACK w/ SWITCH SIGNAL FROM EXTERNAL SYSTEM

- Typical for Hold On and Hold Off applications
- BROWN switch input can be activated by external signals +5VDC or higher (i.e. logic high)
- For hold on and hold off applications, switch input can also be configured to activate on logic low
- If no sensor is present, tie power pack low voltage white wire to low voltage red wire

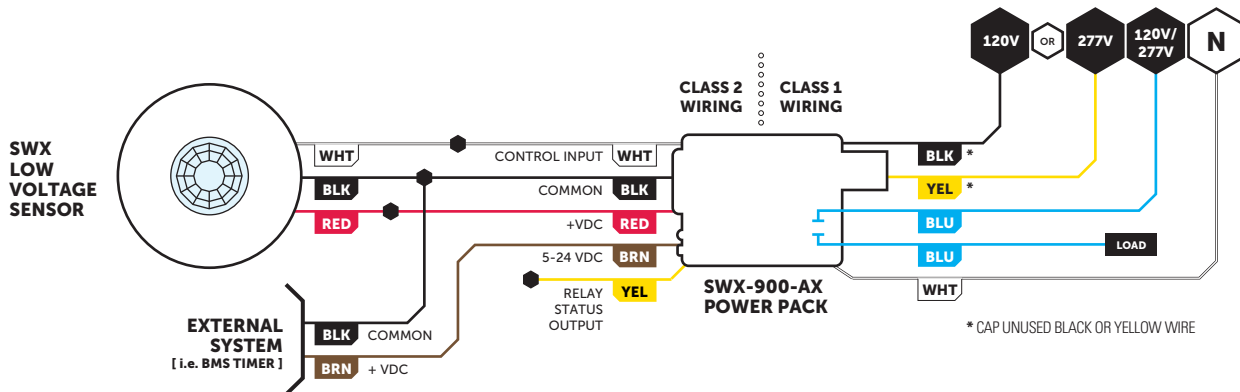

POWER PACK CAPACITY

SWX-900 series power packs can supply power to several occupancy sensors and additional secondary relay packs. Following the below formula ensures adequate power will be available. Note the **SWX-900's** relay has already been factored into the formula.

$$[(\# \text{ of PIR SENSORS}) \times 5\text{mA}] + [(\# \text{ of DUAL TECH SENSORS}) \times 10\text{mA}] + [(\# \text{ of SWX-910}) \times 70\text{mA}] < [(\# \text{ of SWX-900}) \times 80 \text{mA}]$$

EXAMPLE COMBINATIONS

PIR SENSORS			DUAL TECH SENSORS			SECONDARY PACKS SWX-910			TOTAL POWER REQUIRED		POWER SUPPLIED BY ONE SWX-900
#	POWER REQUIRED		#	POWER REQUIRED		#	POWER REQUIRED				
10	50mA	+	0	0	+	0	0	=	50mA	<	80mA
1	5mA	+	0	0	+	1	70mA	=	75mA	<	80mA
0	0	+	6	60mA	+	0	0	=	60mA	<	80mA
3	15mA	+	3	30mA	+	0	0	=	45mA	<	80mA

TESTING & TROUBLESHOOTING

TEST MODE

To test unit and line voltage wiring, press and release the black pushbutton one time (located on the end of the pack opposite the chase nipple). After a short pause, the unit's internal relay (and thus also the connected lighting load) will change state briefly and then return back to its original state if wired and functioning properly.

RESET

To restore factory settings, press and release the push-button 3 times, wait 2 seconds, then press and release the push-button 3 times again.

LED INDICATION

- During normal operation, the LED regularly flashes white as a status "heartbeat".
- The LED will flash blue once when the unit switches.
- If the LED repeatedly double flashes blue, the power supply is overloaded. This is probably due to having too many sensors or secondary relay packs connected. Remove excess low voltage load from the red wire until blue double flash stops.
- If the LED regularly flashes blue, both blue relay wires are connected to power when the relay is open. This indicates probable miswiring.

CONFIGURATION SETTINGS

OPERATIONAL MODES

Standard power packs (model **SWX-900**) and secondary packs (model **SWX-910**) close their relays automatically when a connected sensor signals occupancy. Versions with the

Auxiliary Switch Input option (e.g. model **SWX-900-AX**) have several additional modes of operation that are listed below. Auto On/Auto Off (Setting #2) is the default mode.

SETTING #	MODE	DESCRIPTION
2	Auto On / Auto Off Mode* (Occupancy Mode)	Lights come on automatically when occupancy is detected and turn off automatically after sensor's time delay expires.
3	Manual On / Auto Off (Vacancy Mode)	Lights must be manually switched on via a connected switch, but turn off automatically after sensor's time delay expires.
4	Unused	NA
5	Override On / Logic High	Lights are held on when auxiliary switch input wire is logic high (5-24VDC). Occupancy is ignored.
6	Override On / Logic Low	Lights are held on when auxiliary switch input wire is logic low (< 5VDC). Occupancy is ignored.
7	Override Off / Logic High	Lights are held off when auxiliary switch input wire is logic high (5-24VDC). Occupancy is ignored.
8	Override Off / Logic Low	Lights are held off when auxiliary switch input wire is logic low (< 5VDC). Occupancy is ignored.

TO CHANGE THE OPERATIONAL MODE

1. Read through the above list and note the number of the desired setting
2. Press and release the unit's pushbutton twice, then wait 2 seconds. The White LED will blink back the number of the current setting (e.g. 2 = Auto On / Auto Off).
3. Press the pushbutton the number times equal to the new desired setting (e.g. 3 = Manual On / Auto Off). The White LED will blink back the new setting as confirmation.
4. New setting is saved after White LED blinks confirmation 3 times. If Blue LED double flashes at any time, start process over.

LED OPERATION

To disable the LED from continuously flashing white as a "heartbeat", press and release the push-button 4 times, wait 2 seconds, then press and release the push-button 4 times again.

RELAY LOGIC

The power pack's relay closes in response to occupancy being detected. To reverse this logic (such that the relay opens in response to occupancy), press and release the push-button 5 times, wait 2 seconds, then press and release the push-button 3 times again.

ADDITIONAL OPERATION NOTES

- When in Auto-on/Auto-off mode, if lights are manually switched off when there are still occupants in a space (to show a presentation for example), they will remain off until either switched back on manually or the sensor times out once the space is empty.
- When in Manual On / Auto Off mode, if the switch is pressed but no occupancy is ever sensed, the lights will come on for 1 minute and then shut off. If no occupancy sensor is present, tie the power pack's white input wire to red (+VDC).

CONFIGURATION QUICK REFERENCE TABLE

FUNCTION	SETTING	DESCRIPTION
2 => Operational Modes	2	Auto-On / Auto Off (Occupancy Mode)
	3	Manual On / Auto Off (Vacancy Mode)
	4	Not Used
	5	Override On, Logic High
	6	Override On, Logic Low
	7	Override Off, Logic High
	8	Override Off, Logic Low
	3 => Reset	3
4 => LED Operation	2	LED Enabled
	4	LED Disabled
5 => Relay Logic	2	Normal Relay Logic
	3	Inverted Relay Logic

