

MLED



**WARNING – PLEASE READ ALL INSTRUCTIONS PRIOR TO INSTALLATION
READ AND FOLLOW ALL WARNINGS AND INSTRUCTIONS BEFORE INSTALLING OR MAINTAINING THIS PRODUCT.
TURN OFF POWER PRIOR TO ANY WORK ON THE SYSTEM OR PRODUCT.
DO NOT INSTALL DAMAGED PRODUCT.**

Installing, wiring, and maintenance must be done by qualified persons or a certified electrician in accordance with all local and National Electrical Codes.

Warranty is voided in case of unauthorized modifications and/or improper use.

Save these instructions and refer to them when additions, changes, or services to the fixture are made.

CAUTION – Do not install any fixture assembly closer than 6 inches (15.24 cm) from any combustible material.

Ensure that this product is compatible with electrical dimming protocols.

Suitable for dry locations only.

⚠ WARNING ⚠

- To avoid possible electrical shock, before installing light fixtures, disconnect power by turning off the circuit breakers both to the outlet box and to its associated wall switch location if you cannot lock the circuit breakers in the off position, securely fasten a prominent warning device, such as a tag to the service panel.
- Verify that supply voltage is correct by comparing it with the luminaire label information.
- Make all electrical and grounded connections in the accordance with the National Electrical Code (NEC) and any applicable local code requirements.
- Allow sufficient time for fixture and / or driver to cool before servicing and performing maintenance.

⚠ ADVERTENCIA ⚠

- Para evitar un posible choque, antes de instalar luminarias, desconecte la alimentación apagando los interruptores de circuito y ubicación del interruptor de pared. Si no se pueden bloquear los interruptores en la posición de apagado, sujetar un dispositivo de advertencia en el panel de servicio.
- Compruebe que la tensión de alimentación es correcta comparándola con la información de etiqueta de la luminaria.
- Hacer todas las conexiones eléctricas y puesta a tierra de acuerdo con el código eléctrico nacional (NEC) y los requisitos del código local aplicable.
- Permitir suficiente tiempo para el luminario y el controlador para enfriar antes de enesar el servicios y mantenimiento.

⚠ AVERTISSEMENT ⚠

- Pour éviter les chocs, avant d'installer des appareils d'éclairage, coupez l'alimentation en désactivant les disjoncteurs et l'emplacement du commutateur mural. Si vous ne pouvez pas verrouiller les disjoncteurs en position d'arrêt, fixer un avertissement sur le panneau de service.
- Vérifiez que la tension d'alimentation est correcte en le comparant avec les informations d'étiquette de luminaire.
- Effectuer tous les raccordements électriques et mise à la terre dans la conformité avec le Code électrique National (NEC) et des exigences du code local applicable.
- Laisser suffisamment de temps pour l'appareil et pilote refroidir avant d'effectuer l'entretien et la maintenance.

⚠ CAUTION ⚠

- All wiring must be in accordance with national and local electrical codes and ANSI/NFPA 70. If you are unfamiliar with wiring you should use qualified electrician.
- PPE Personal Protective Equipment such as gloves and safety glasses should be used at all times when installing, maintaining or servicing.
- Risk of fire. Keep combustible material away from fixtures.

⚠ PRECAUCION ⚠

- Todo el cableado debe hacerse de conformidad con los códigos eléctricos nacionales y locales y ANSI/NFPA 70. Si no está familiarizado con el cableado, se debe utilizar a un electricista.
- Equipo de protección personal como guantes y lentes de seguridad se debe utilizar al instalar, mantener o reparar.
- Riesgo de incendio. Mantenga los materiales combustibles lejos de los liminario.

⚠ MIS EN GARDE ⚠

- Tout le câblage doit être effectué conformément aux codes électriques locaux et nationaux et ANSI/NFPA 70. Si vous êtes peu familier avec câblage, vous devez utiliser un électricien qualifié.
- Équipement de protection personnelle comme des gants et des lunettes de sécurité doivent être utilisé en tout temps lors de l'installation, maintenance ou entretien.
- Risque d'incendie. Garder les matières combustibles loin de luminaires.

INSTRUCTIONS FOR USE

- 1 De-energize circuit before installation.
- 2 Use 1.5mm allen key to remove back plate assembly.
- 3 Install back plate to a J-Box (J-Box and mounting hardware supplied by others) for use with 3-1/2" and 4" octagonal or square recessed junction boxes with 2-3/4" mounting hole spacing. (Appropriate device ring cover may be required and to be supplied by others.)
- 4 Properly ground back plate assembly in accordance with all local and national electrical codes.
- 5 Connect primary voltage from the building to the line and neutral leads to the back plate assembly. Refer to product label for required input voltage.
- 6 If required, adjust strain relief (not shown) with small flat head screwdriver.
- 7 Attach quick disconnect, align canopy with back plate assembly, and secure using the 1.5 mm allen key.
- 8 Screw on decorative shade.
- 9 Energize circuit and test for proper operation.

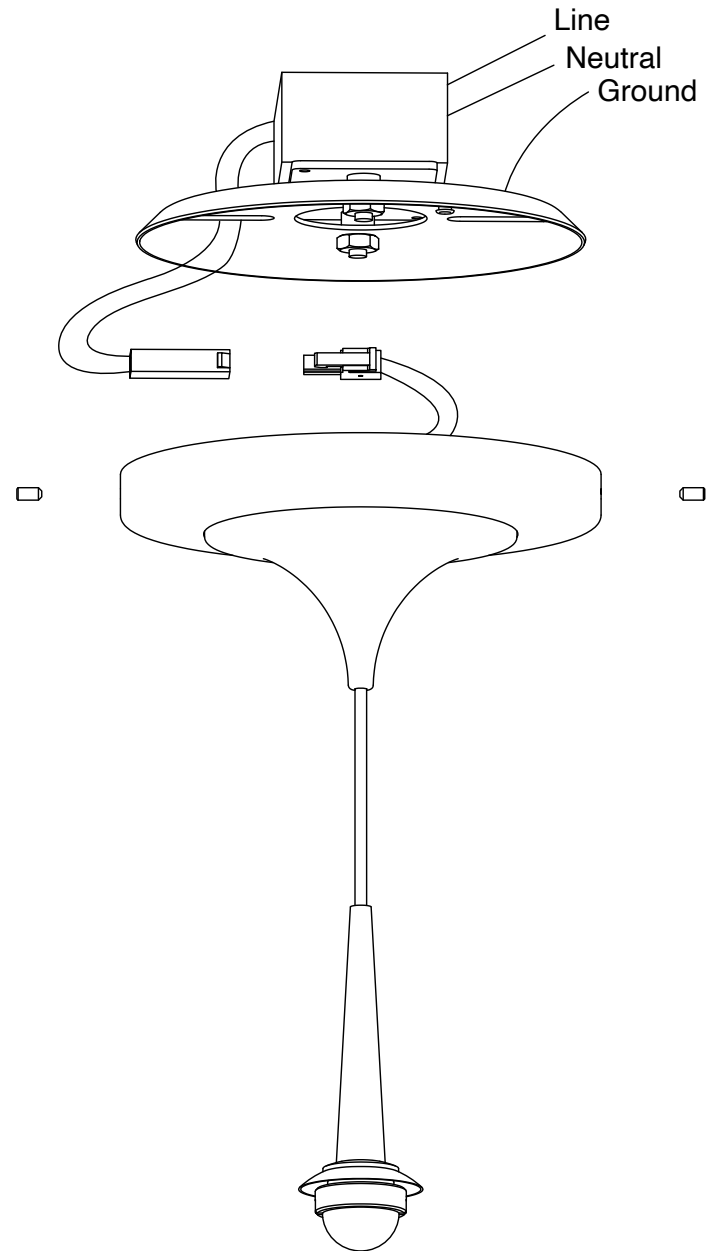

ECO/HALO Fixture Mounting

**WARNING – PLEASE READ ALL INSTRUCTIONS PRIOR TO INSTALLATION
READ AND FOLLOW ALL WARNINGS AND INSTRUCTIONS BEFORE INSTALLING OR MAINTAINING THIS PRODUCT.
TURN OFF POWER PRIOR TO ANY WORK ON THE SYSTEM OR PRODUCT.
DO NOT INSTALL DAMAGED PRODUCT.**



Installation, wiring, and maintenance must be done by a certified electrician in accordance with all local and National Electrical Codes.

Warranty is voided in case of unauthorized modifications and/or improper use.

Save these instructions and refer to them when additions, changes, or services to the fixture or the track system are made.

CAUTION – Do not install any fixture assembly closer than 6 inches (15.24cm) from any combustible material.

Do not install any part of a track system less than 5 feet (1.542 m) above the floor.

Do not attempt to energize anything other than track luminaires on track.

Suitable for dry locations only.

⚠ WARNING ⚠

- To avoid possible electrical shock, before installing light fixtures, disconnect power by turning off the circuit breakers both to the outlet box and to its associated wall switch location if you cannot lock the circuit breakers in the off position, securely fasten a prominent warning device, such as a tag to the service panel.
- Verify that supply voltage is correct by comparing it with the luminaire label information.
- Make all electrical and grounded connections in the accordance with the National Electrical Code (NEC) and any applicable local code requirements.
- Allow sufficient time for fixture and / or driver to cool before servicing and performing maintenance.

⚠ ADVERTENCIA ⚠

- Para evitar un posible choque, antes de instalar luminarias, desconecte la alimentación apagando los interruptores de circuito y ubicación del interruptor de pared. Si no se pueden bloquear los interruptores en la posición de apagado, sujetar un dispositivo de advertencia en el panel de servicio.
- Compruebe que la tensión de alimentación es correcta comparándola con la información de etiqueta de la luminaria.
- Hacer todas las conexiones eléctricas y puesta a tierra de acuerdo con el código eléctrico nacional (NEC) y los requisitos del código local aplicable.
- Permitir suficiente tiempo para el luminario y el controlador para enfriar antes de enesar el servicios y mantenimiento.

⚠ AVERTISSEMENT ⚠

- Pour éviter les chocs, avant d'installer des appareils d'éclairage, coupez l'alimentation en désactivant les disjoncteurs et l'emplacement du commutateur mural. Si vous ne pouvez pas verrouiller les disjoncteurs en position d'arrêt, fixer un avertissement sur le panneau de service.
- Vérifiez que la tension d'alimentation est correcte en le comparant avec les informations d'étiquette de luminaire.
- Effectuer tous les raccordements électriques et mise à la terre dans la conformité avec le Code électrique National (NEC) et des exigences du code local applicable.
- Laisser suffisamment de temps pour l'appareil et pilote refroidir avant d'effectuer l'entretien et la maintenance.

⚠ CAUTION ⚠

- All wiring must be in accordance with national and local electrical codes and ANSI/NFPA 70. If you are unfamiliar with wiring you should use qualified electrician.
- PPE Personal Protective Equipment such as gloves and safety glasses should be used at all times when installing, maintaining or servicing.
- Risk of fire. Keep combustible material away from fixtures.

⚠ PRECAUCION ⚠

- Todo el cableado debe hacerse de conformidad con los códigos eléctricos nacionales y locales y ANSI/NFPA 70. Si no está familiarizado con el cableado, se debe utilizar a un electricista.
- Equipo de protección personal como guantes y lentes de seguridad se debe utilizar al instalar, mantener o reparar.
- Riesgo de incendio. Mantenga los materiales combustibles lejos de los liminario.

⚠ MIS EN GARDE ⚠

- Tout le câblage doit être effectué conformément aux codes électriques locaux et nationaux et ANSI/NFPA 70. Si vous êtes peu familier avec câblage, vous devez utiliser un électricien qualifié.
- Équipement de protection personnelle comme des gants et des lunettes de sécurité doivent être utilisé en tout temps lors de l'installation, maintenance ou entretien.
- Risque d'incendie. Garder les matières combustibles loin de luminaires.

ECO INSTALLATION/REMOVAL INSTRUCTIONS

INSTRUCTIONS FOR USE

- 1 De-energize circuit before installation.
- 2 Depress Eco track adapter contact tabs to ensure electrical contact tabs are fully seated on the ECO track adapter before inserting into ECO track.
- 3 Align release tab to the groove (polarity) side of the ECO track.
- 4 While inserting the ECO adapter into the ECO track, twist the ECO adapter counterclockwise 90 degrees. ECO adapter will snap into the ECO track.
- 5 Polarity line on ECO adapter must align with polarity line on ECO track.
- 6 Energize circuit and test for proper operation.

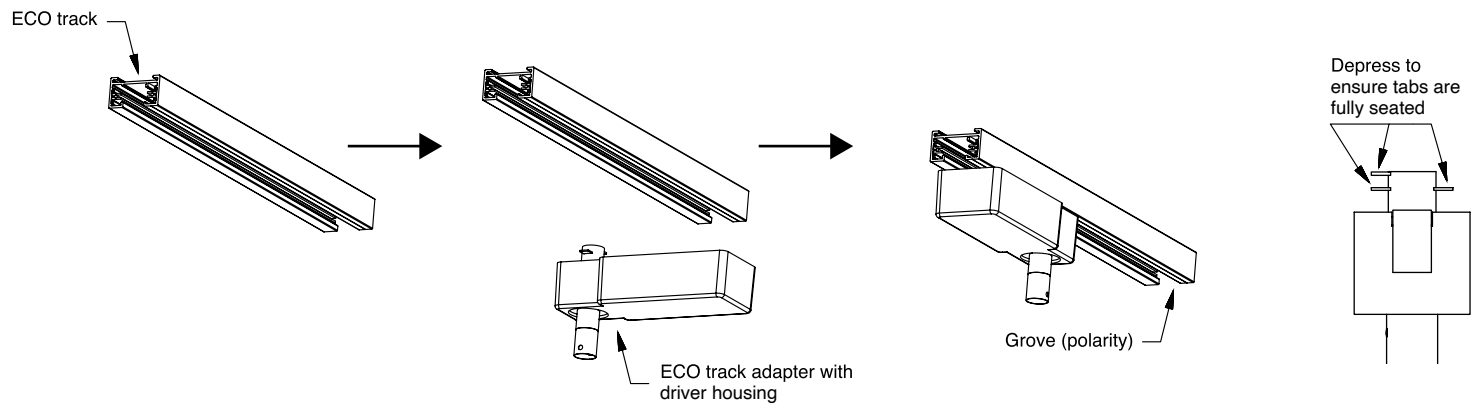

REMOVAL

- 1 Hold fixture body.
- 2 Depress the release tab on the ECO adapter.
- 3 Rotate the ECO adapter clockwise 90 degrees, releasing it from the ECO track.
- 4 Reposition or replace as required.

HALO INSTALLATION/REMOVAL INSTRUCTIONS

INSTRUCTIONS FOR USE

- 1 Put the track adaptor into the track groove, then squeeze out the cover cap by holding the lamp.
- 2 Rotate the adaptor by 90 degree in anti-clockwise direction, then the adaptor will be fixed in the groove.



REMOVAL

- 1 Pull out the cover cap by holding the lamp.
- 2 Rotate the adaptor by 90 degree in clockwise direction, then pull out the lamp.

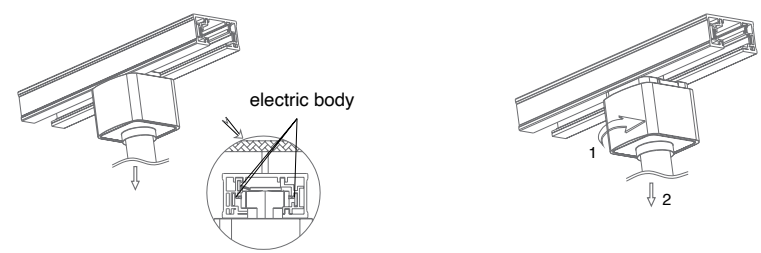

ZONYX Fixture Mounting

**WARNING – PLEASE READ ALL INSTRUCTIONS PRIOR TO INSTALLATION
READ AND FOLLOW ALL WARNINGS AND INSTRUCTIONS BEFORE INSTALLING OR MAINTAINING THIS PRODUCT.
TURN OFF POWER PRIOR TO ANY WORK ON THE SYSTEM OR PRODUCT.
DO NOT INSTALL DAMAGED PRODUCT.**

Installing, wiring and maintenance must be done by qualified persons or a certified electrician in accordance with all local and National Electrical Code.

Warranty is voided in case of unauthorized modifications and/ or improper use.

Save these instructions. Use as reference when service or maintenance is performed.

CAUTION – Do not install any fixture assembly closer than 6 inches from any combustible material.

Do not install any part of a ZONYX track system less than 7 feet above the floor.

Do not attempt to energize anything other than ZONYX track luminaires on track.

Suitable for dry locations only.

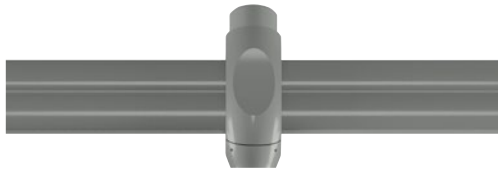

⚠ WARNING ⚠

- To avoid possible electrical shock, before installing light fixtures, disconnect power by turning off the circuit breakers both to the outlet box and to its associated wall switch location if you cannot lock the circuit breakers in the off position, securely fasten a prominent warning device, such as a tag to the service panel.
- Verify that supply voltage is correct by comparing it with the luminaire label information.
- Make all electrical and grounded connections in the accordance with the National Electrical Code (NEC) and any applicable local code requirements.
- Allow sufficient time for fixture and / or driver to cool before servicing and performing maintenance.

⚠ CAUTION ⚠

- All wiring must be in accordance with national and local electrical codes and ANSI/NFPA 70. If you are unfamiliar with wiring you should use qualified electrician.
- PPE Personal Protective Equipment such as gloves and safety glasses should be used at all times when installing, maintaining or servicing.
- Risk of fire. Keep combustible material away from fixtures.

⚠ ADVERTENCIA ⚠

- Para evitar un posible choque, antes de instalar luminarias, desconecte la alimentación apagando los interruptores de circuito y ubicación del interruptor de pared. Si no se pueden bloquear los interruptores en la posición de apagado, sujetar un dispositivo de advertencia en el panel de servicio.
- Compruebe que la tensión de alimentación es correcta comparándola con la información de etiqueta de la luminaria.
- Hacer todas las conexiones eléctricas y puesta a tierra de acuerdo con el código eléctrico nacional (NEC) y los requisitos del código local aplicable.
- Permitir suficiente tiempo para el luminario y el controlador para enfriar antes de enpesar el servicios y mantenimiento.

⚠ PRECAUCION ⚠

- Todo el cableado debe hacerse de conformidad con los códigos eléctricos nacionales y locales y ANSI/NFPA 70. Si no está familiarizado con el cableado, se debe utilizar a un electricista.
- Equipo de protección personal como guantes y lentes de seguridad se debe utilizar al instalar, mantener o reparar.
- Riesgo de incendio. Mantenga los materiales combustibles lejos de los liminario.

⚠ AVERTISSEMENT ⚠

- Pour éviter les chocs, avant d'installer des appareils d'éclairage, coupez l'alimentation en désactivant les disjoncteurs et l'emplacement du commutateur mural. Si vous ne pouvez pas verrouiller les disjoncteurs en position d'arrêt, fixer un avertissement sur le panneau de service.
- Vérifiez que la tension d'alimentation est correcte en le comparant avec les informations d'étiquette de luminaire.
- Effectuer tous les raccordements électriques et mise à la terre dans la conformité avec le Code électrique National (NEC) et des exigences du code local applicable.
- Laisser suffisamment de temps pour l'appareil et pilote refroidir avant d'effectuer l'entretien et la maintenance.

⚠ MIS EN GARDE ⚠

- Tout le câblage doit être effectué conformément aux codes électriques locaux et nationaux et ANSI/NFPA 70. Si vous êtes peu familier avec câblage, vous devez utiliser un électricien qualifié.
- Équipement de protection personnelle comme des gants et des lunettes de sécurité doivent être utilisé en tout temps lors de l'installation, maintenance ou entretien.
- Risque d'incendie. Garder les matières combustibles loin de luminaires.

INSTRUCTIONS FOR USE

- 1 De-energize circuit before installation.
- 2 To attach fixture to Zonyx track, slide it from top and press into track. Close part (A) and install cap (B).
- 3 Energize circuit and test for proper operation

REMOVAL

- 1 De-energize circuit before removal.
- 2 Hold Zonyx track adapter and unscrew cap (B).
- 3 Open part (A) and remove adapter from track.
- 4 Reposition or replace as required.
- 5 Energize circuit and test for proper operation.

ADAPTER

The Zonyx adapter clamps directly onto the track. Make sure the lamp is secure in the socket and the fixture is attached to the adapter. Do not connect track with parts other than those stated for Zonyx system. All connections after installing or adjusting the fixture must be clean and tight to avoid arcing and overheating; failure to do so may result in subsequent lamp, fixture, or system failure.

IMPORTANT WARNING! - When turning the retaining collar (B), adjusting the direction of the fixture, or moving the fixture in any way **DO NOT** loosen the adapter receptacle (A). Tighten the receptacle (A) by turning in a clockwise direction. All connections after installing or adjusting the fixture must be clean and tight to avoid arcing and overheating; failure to do so may result in subsequent lamp, fixture, or system failure!

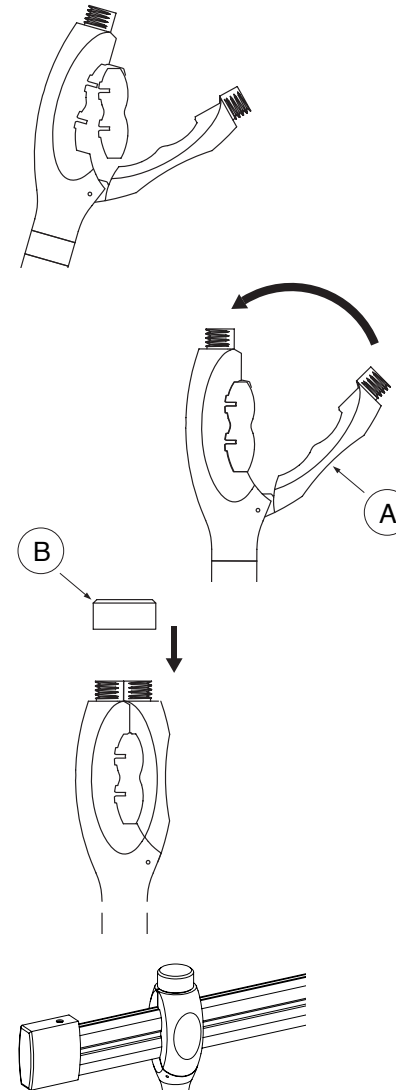

GEO Fixture Mounting

**WARNING – PLEASE READ ALL INSTRUCTIONS PRIOR TO INSTALLATION
READ AND FOLLOW ALL WARNINGS AND INSTRUCTIONS BEFORE INSTALLING OR MAINTAINING THIS PRODUCT.
TURN OFF POWER PRIOR TO ANY WORK ON THE SYSTEM OR PRODUCT.
DO NOT INSTALL DAMAGED PRODUCT.**

Installation, wiring, and maintenance must be done by a certified electrician in accordance with all local and National Electrical Codes.

Warranty is voided in case of unauthorized modifications and/or improper use.

Save these instructions and refer to them when additions, changes, or services to the GEO fixture or the GEO track system is made.

CAUTION – Do not install any fixture assembly closer than 6 inches (15.24 cm) from any combustible material.

Do not install any part of an GEO track system less than 5 feet (1.542 m) above the floor.

Do not attempt to energize anything other than GEO track luminaires on track.

Suitable for dry locations only.



⚠ WARNING ⚠

- To avoid possible electrical shock, before installing light fixtures, disconnect power by turning off the circuit breakers both to the outlet box and to its associated wall switch location if you cannot lock the circuit breakers in the off position, securely fasten a prominent warning device, such as a tag to the service panel.
- Verify that supply voltage is correct by comparing it with the luminaire label information.
- Make all electrical and grounded connections in the accordance with the National Electrical Code (NEC) and any applicable local code requirements.
- Allow sufficient time for fixture and / or driver to cool before servicing and performing maintenance.

⚠ ADVERTENCIA ⚠

- Para evitar un posible choque, antes de instalar luminarias, desconecte la alimentación apagando los interruptores de circuito y ubicación del interruptor de pared. Si no se pueden bloquear los interruptores en la posición de apagado, sujetar un dispositivo de advertencia en el panel de servicio.
- Compruebe que la tensión de alimentación es correcta comparándola con la información de etiqueta de la luminaria.
- Hacer todas las conexiones eléctricas y puesta a tierra de acuerdo con el código eléctrico nacional (NEC) y los requisitos del código local aplicable.
- Permitir suficiente tiempo para el luminario y el controlador para enfriar antes de enpesar el servicios y mantenimiento.

⚠ AVERTISSEMENT ⚠

- Pour éviter les chocs, avant d'installer des appareils d'éclairage, coupez l'alimentation en désactivant les disjoncteurs et l'emplacement du commutateur mural. Si vous ne pouvez pas verrouiller les disjoncteurs en position d'arrêt, fixer un avertissement sur le panneau de service.
- Vérifiez que la tension d'alimentation est correcte en le comparant avec les informations d'étiquette de luminaire.
- Effectuer tous les raccordements électriques et mise à la terre dans la conformité avec le Code électrique National (NEC) et des exigences du code local applicable.
- Laisser suffisamment de temps pour l'appareil et pilote refroidir avant d'effectuer l'entretien et la maintenance.

⚠ CAUTION ⚠

- All wiring must be in accordance with national and local electrical codes and ANSI/NFPA 70. If you are unfamiliar with wiring you should use qualified electrician.
- PPE Personal Protective Equipment such as gloves and safety glasses should be used at all times when installing, maintaining or servicing.
- Risk of fire. Keep combustible material away from fixtures.

⚠ PRECAUCION ⚠

- Todo el cableado debe hacerse de conformidad con los códigos eléctricos nacionales y locales y ANSI/NFPA 70. Si no está familiarizado con el cableado, se debe utilizar a un electricista.
- Equipo de protección personal como guantes y lentes de seguridad se debe utilizar al instalar, mantener o reparar.
- Riesgo de incendio. Mantenga los materiales combustibles lejos de los liminario.

⚠ MIS EN GARDE ⚠

- Tout le câblage doit être effectué conformément aux codes électriques locaux et nationaux et ANSI/NFPA 70. Si vous êtes peu familier avec câblage, vous devez utiliser un électricien qualifié.
- Équipement de protection personnelle comme des gants et des lunettes de sécurité doivent être utilisé en tout temps lors de l'installation, maintenance ou entretien.
- Risque d'incendie. Garder les matières combustibles loin de luminaires.

INSTRUCTIONS FOR USE

- 1 De-energize circuit before installation.
- 2 Ensure polarity groove is in line with polarity ridge on the track.
- 3 Insert the forward edge of fixture adapter into the track and tilt up into position.
- 4 Turn the mechanical fixing knob clockwise to secure the fixture adapter to track.
- 5 Select the desired circuit by turning the circuit selector switch to 1 or 2.
- 6 Energize track circuits and test for proper operation.
- 7 Place fixture into desired position and use rotation lock screw to secure. (Do not overtighten)

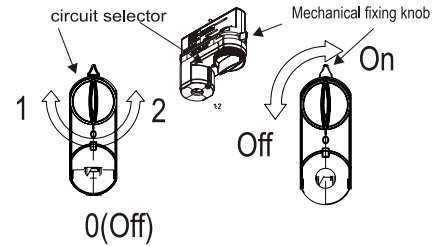
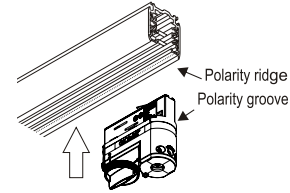

REMOVAL

- 1 De-energize circuit before removal and allow sufficient time to cool before servicing.
- 2 Return circuit selector switch to original position before removal.
- 3 Hold fixture body and adapter.
- 4 Turn mechanical fixing knob 90 degrees to release fixture from track.
- 5 Tilt fixture adapter away from track and reposition, remove, or replace as required.
- 6 Energize track circuits and test for proper operation.

rotation lock screw, (do not overtighten)

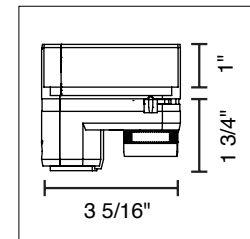
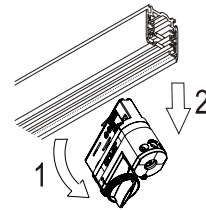
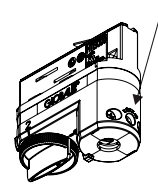

Conduit Canopy Cover



**WARNING – PLEASE READ ALL INSTRUCTIONS PRIOR TO INSTALLATION
 READ AND FOLLOW ALL WARNINGS AND INSTRUCTIONS BEFORE INSTALLING OR MAINTAINING THIS PRODUCT.
 TURN OFF POWER PRIOR TO ANY WORK ON THE SYSTEM OR PRODUCT.
 DO NOT INSTALL DAMAGED PRODUCT.**

Installing, wiring, and maintenance must be done by qualified persons or a certified electrician in accordance with all local and National Electrical Codes.

Warranty is voided in case of unauthorized modifications and/or improper use.

Save these instructions. Use as reference when service or maintenance is performed.

Suitable for dry locations only.

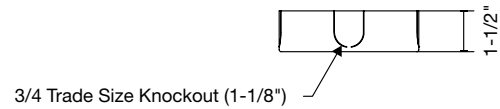
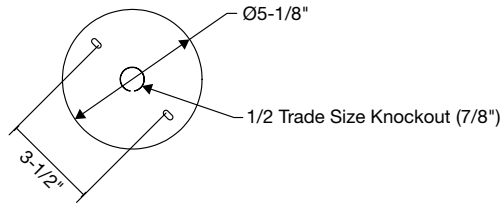

⚠ WARNING ⚠

- To avoid possible electrical shock, before installing light fixtures, disconnect power by turning off the circuit breakers both to the outlet box and to its associated wall switch location if you cannot lock the circuit breakers in the off position, securely fasten a prominent warning device, such as a tag to the service panel.
- Verify that supply voltage is correct by comparing it with the luminaire label information.
- Make all electrical and grounded connections in the accordance with the National Electrical Code (NEC) and any applicable local code requirements.
- Allow sufficient time for fixture and / or driver to cool before servicing and performing maintenance.

⚠ CAUTION ⚠

All wiring must be in accordance with national and local electrical codes and ANSI/NFPA 70. If you are unfamiliar with wiring you should use qualified electrician.

PPE Personal Protective Equipment such as gloves and safety glasses should be used at all times when installing, maintaining or servicing.

Risk of fire. Keep combustible material away from fixtures.

⚠ ADVERTENCIA ⚠

- Para evitar un posible choque, antes de instalar luminarias, desconecte la alimentación apagando los interruptores de circuito y ubicación del interruptor de pared. Si no se pueden bloquear los interruptores en la posición de apagado, sujetar un dispositivo de advertencia en el panel de servicio.
- Compruebe que la tensión de alimentación es correcta comparándola con la información de etiqueta de la luminaria.
- Hacer todas las conexiones eléctricas y puesta a tierra de acuerdo con el código eléctrico nacional (NEC) y los requisitos del código local aplicable.
- Permitir suficiente tiempo para el luminario y el controlador para enfriar antes de empezar los servicios y mantenimiento.

⚠ PRECAUCION ⚠

Todo el cableado debe hacerse de conformidad con los códigos eléctricos nacionales y locales y ANSI/NFPA 70. Si no está familiarizado con el cableado, se debe utilizar a un electricista.

Equipo de protección personal como guantes y lentes de seguridad se debe utilizar al instalar, mantener o reparar.

Riesgo de incendio. Mantenga los materiales combustibles lejos de los luminario.

⚠ AVERTISSEMENT ⚠

- Pour éviter les chocs, avant d'installer des appareils d'éclairage, coupez l'alimentation en désactivant les disjoncteurs et l'emplacement du commutateur mural. Si vous ne pouvez pas verrouiller les disjoncteurs en position d'arrêt, fixer un avertissement sur le panneau de service.
- Vérifiez que la tension d'alimentation est correcte en le comparant avec les informations d'étiquette de luminaire.
- Effectuer tous les raccordements électriques et mise à la terre dans la conformité avec le Code électrique National (NEC) et des exigences du code local applicable.
- Laisser suffisamment de temps pour l'appareil et pilote refroidir avant d'effectuer l'entretien et la maintenance.

⚠ MIS EN GARDE ⚠

Tout le câblage doit être effectué conformément aux codes électriques locaux et nationaux et ANSI/NFPA 70. Si vous êtes peu familier avec câblage, vous devez utiliser un électricien qualifié.

Équipement de protection personnelle comme des gants et des lunettes de sécurité doivent être utilisés en tout temps lors de l'installation, maintenance ou entretien.

Risque d'incendie. Garder les matières combustibles loin de luminaires.

INSTRUCTIONS FOR USE

- 1 To be used with 4" x 1-1/2" Octagonal junction box only.
- 2 De-energize circuit before installation.
- 3 Align cover prior to installation to ensure the removal of the correct knockouts.
- 4 NOTE – Prior to installation, electrical conduit connector setscrews MUST be rotated to face mounting surface (back of junction box.)
- 5 For through wiring, remove knockout and fasten fixture mounting bracket and junction box cover. Use appropriate connectors to attach both items.
- 6 Make the electrical connections.
- 7 Properly ground as required by local and national electrical codes.
- 8 Align fixture mounting bracket and junction box cover. Install simultaneously using screws provided by others.
- 9 Energize circuit and test for proper operation.

