



# FHSCP-UNV-10W-L-SD



## Emergency LED Driver

- Universal Voltage: 120-277VAC, 50/60Hz
- Output Voltage Range: 15-55V  $\overline{\text{---}}$
- Output Current: 181-666mA
- Output Wattage: 10W
- Output Type: LED Class 2
- Number of Output Channels: 1 Channel
- Dry and Damp

### General Specifications

Input Voltage / Frequency	120-277VAC , 50/60Hz
Input Current	0.1A
Input Power	5W Typical
Maintain Power	<0.85W
Input Power Pass-Through Rating (AC Driver Line)	5A
Max Output Rating (LED+ LED- Terminal)	3A Max
	55V Max
White/Black Lead	2A Max
Output Power	Typical 10W
Output Current Rated	181-666mA
Output Voltage Range	15 - 55V $\overline{\text{---}}$
Number of Output Channels	1 Channel
Test Switch	Bi-Color
Input Surge Protection	3KV/6KV Ring wave, 1KV/2KV Combine surge
Protections	Output Open Protection Output Overload Protection Output Short Circuit Protection
RFI/EMI	FCC Part15A
Ambient Operating Temperature Rang	0°C To 55°C (32°F To 131°F°)
Tc	62°C (143. 6°F)
Sound Rating	A
Battery Type	Lithium-ion
Battery Voltage	10.95V
Pack Capacity	2600mAh
Battery Rating	28.47Wh
Battery Count	3 Cells
Battery Recharge Time	24 Hours
Battery Discharge Time	1.5 Hours Min.
IP Rating	IP20
Test Switch Remote Mounting Distance	20' (6m) Max.
Service Life	50,000 hours @62°C (143. 6°F)
Warranty	@62°C (143. 6°F) 5 Years From the date of manufacture when properly installed
Safety Standard	UL 924, UL 1310, CSA C22.2 No.141



# FHSCP-UNV-10W-L-SD



## Mechanical Data

Overall Dimensions	
Length	9.45" (240mm)
Width	2.05" (52.1mm)
Height	1.34" (34mm)

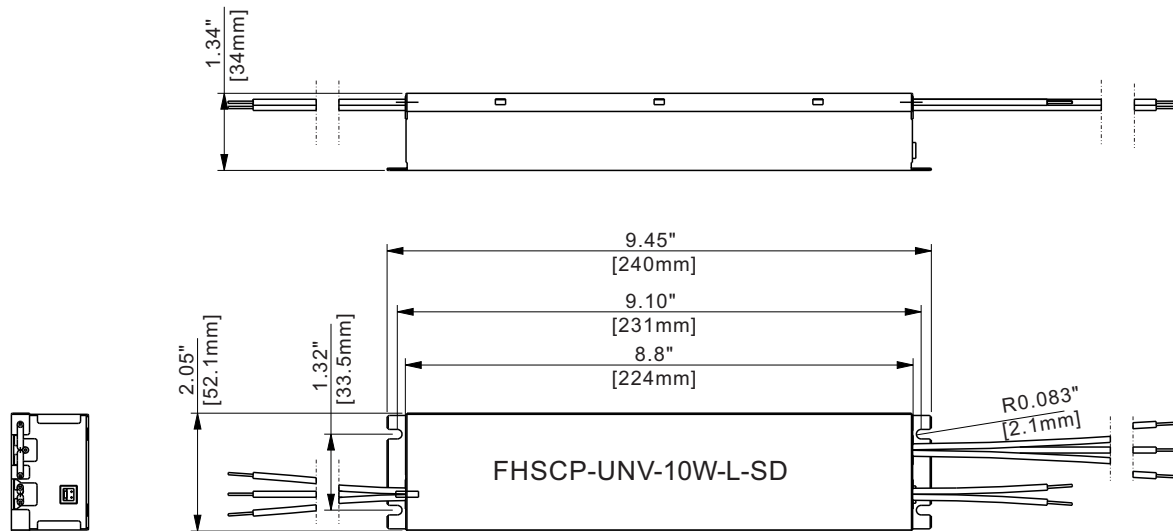

Tolerance=0.02"



# FHSCP-UNV-10W-L-SD



## Accessories

### Test switch wire

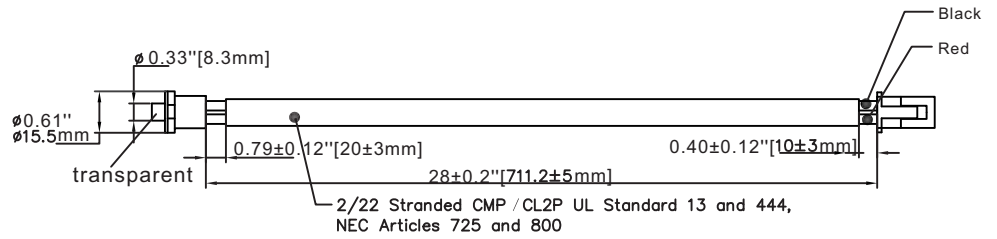

### Wall Plate: FHSWLPWH



Wall plate and screw color:  
white with black lettering

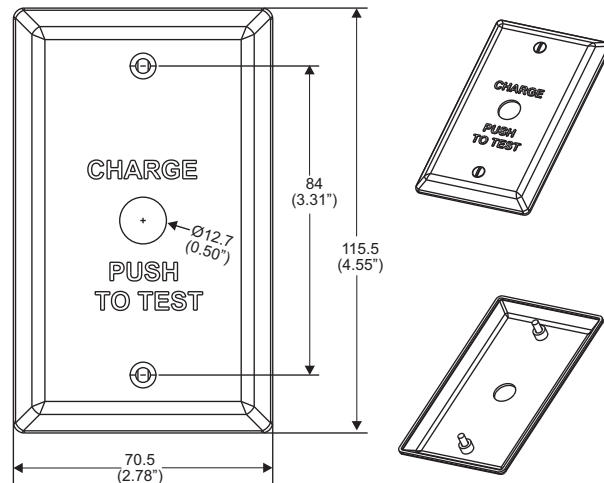

1. "Charge push to Test" plate
2. (2) 6-32 x 1/2" LG mounting screws

### Wall Plate: FHSWLPPWH (Pure White Wall Plate)



Wall plate and screw color:  
Pure white with black lettering



# FHSCP-UNV-10W-L-SD



## Wiring Diagram

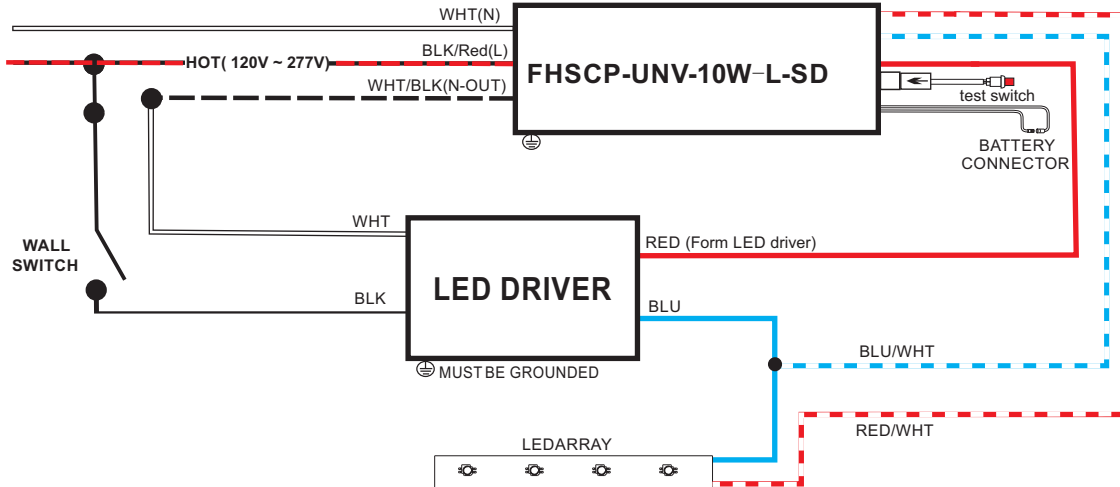

## Wiring Diagram (Emergency Only)

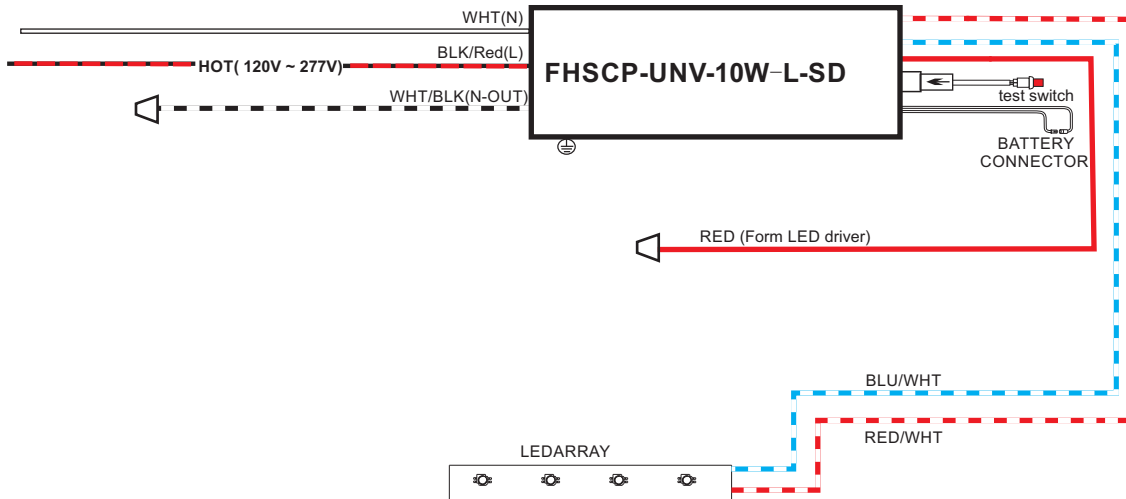



# FHSCP-UNV-10W-L-SD



## SELF-DIAGNOSTIC INSTRUCTIONS / OPERATION:

### If the self-diagnostic feature is enabled:











The emergency LED driver will conduct a self-check for sixty(60) seconds every thirty(30) days; and a ninety(90) minutes self-check every 12 months. After every self-check the LED indicator light will indicate a status signal. Check indicator status chart below to diagnose the status signal.

### If the self-diagnostic feature is disabled:

User must conduct a manual test every thirty (30) days to ensure the emergency LED light source illuminates as intended. A full discharge test shall be conducted once a year; the LED light source shall illuminate for a minimum of ninety (90) minutes.

**\*Self-Diagnostic feature is factory enabled**

## TEST SWITCH INDICATOR STATUS:

LED Indicators Status	EM Driver Status / Mode
 Solid Green	System OK / AC OK (Self-Diagnostic Enabled or Disabled)
 Slow Flashing Red, 4s on / 1s off	Battery NOT detected, check battery switch or connection
 Flashing Red, 1s on / 1s off	Battery Failure, replace battery
 Flashing Green, 1s on / 1s off	Self-Diagnostic test underway
 Slow Flashing Green, 0.1s on / 3s off	Normal working in EM mode
 Solid Red	No load or output over voltage protection triggered , Check LED connection
 Solid Red	Over Current Protection
 Flashing Green, 2s on / 0.5s off	Enables Self-diagnosis
 Flashing Green, 0.5s on / 2s off	Cancel Self-diagnosis
 Flashing Red, 0.5s on / 3s off	Abnormal Power-on Under Self-diagnosis / Battery Voltage abnormal

## TEST SWITCH OPERATIONS

### EM Test:

Press and hold the test button (>1s) to enter EM mode in normal AC powered.

### Manual Self-Diagnostic:

After charging twelve (12) hours at least, quickly press the test button three(3) times to force the controller to enter Self-Diagnostic cycle. To quit the Self-Diagnostic cycle after engaged, press and hold the test button for three (3) seconds.

### Query Self-Diagnostic Status:

Fast click 2 times within 2s to query the Self-Diagnostic status. The indicator would blink for current status for 3 cycles. 2s ON / 0.5s OFF stands for Enabled. 0.5s ON / 2s OFF stands for Disabled.

### How to Enable and Disable Self-Diagnostic Status:

Press and hold the test button for one second, then release, and press and hold the test button for 2 seconds.

### Cancel reporting error:

In standby, press and hold the button for about 5s to cancel the error indication.

### Emergency Battery Disconnect:

Press and hold the test switch for 5 seconds during EM output condition to turn off EM output. This is useful for production environment to turn off the EM output once a luminaire has completed functionality testing.



# FHSCP-UNV-10W-L-SD



---

## Guidelines

### Grounding

- Driver must be grounded by means of the Driver case.

---

### LED Load

- Fulham's Hotspot Constant Power Emergency LED drivers are designed to drive passive LED's, COB's and LED assemblies. Proper function is not guaranteed when (LED) loads with active components are used.

---

### Mounting and cooling

- Above an output power of 10W, the driver need to be mounted on a heat conductive surface of at least 100cm<sup>2</sup>. Always test if the surface is sufficient enough before installing the LED driver.

---

### Short Circuit Protection

- In case of a short circuit the LED driver switches to protection mode. After removal of the short-circuit the LED driver will recover automatically.

---

### No Load Operation

- In no-load operation the output voltage will not exceed the specific open circuit output voltage.

---

### Hot Swapping

- This driver does not support the hot swapping og the LED's.

---

### Remote Mounting

- up to 20ft with 18AWG wire. Contact Fulham for higher remote distance.

---

### Warranty

- Reference Fulham's limited Warranty: <https://cdn.fulham.com/PDFs/Limited-Warranty.pdf>



# FHSCP-UNV-10W-L-SD



## Part Number Matrix

<b>FHS</b>	<b>CP</b>	<b>UNV</b>	<b>10W</b>	<b>L</b>	<b>SD</b>
<u>LED Driver</u>	<u>Driver Type</u>	<u>Input Voltage</u>	<u>Max Output Power</u>	<u>Case Type</u>	<u>Special Features</u>
FHS = FireHorse HotSpot Driver	CP = Constant Power	UNV = 120V-277V	10W = 10 Watts	L = Long Case	SD = Self Diagnostic

## Product Image: FHSCP-UNV-10W-L-SD



## Packaging

Master Carton

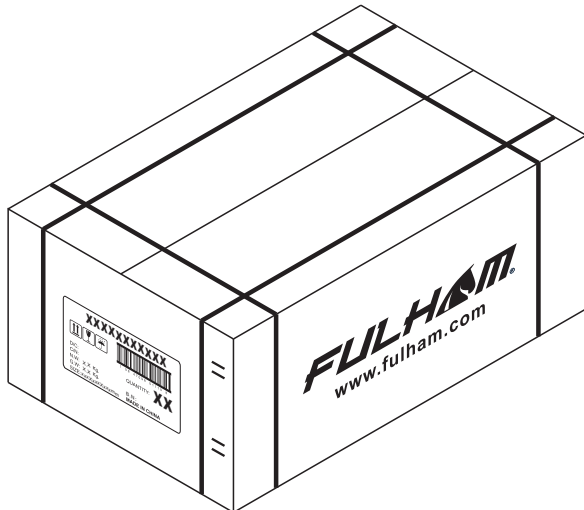

OUTER DIMENSION		
L	W	H
464mm (18.27")	364mm (14.33")	193mm (7.60")
Net Weight	Gross Weight	QUANTITY
9.8KG 21.60lbs	11.5KG 25.35lbs	20