

# WIRELESS CORNER MOUNT PIR OCCUPANCY SENSOR

LMPX-600



- Dual IPv6 and Bluetooth® low energy antennas provide robust signal strength and reliable communication
- Uses IPV6 to establish network communication with all DLM wireless devices
- Quick and easy wireless installation
- Up to 10-year battery life; battery level can be viewed with wireless DLM software
- Commissioning using DLM Configuration App
- Compact 2" x 5.7" sensor mounts easily on a wall, corner, or ceiling; multiple mounting options provide flexibility



## DESCRIPTION

The LMPX-600 wireless low profile Digital PIR Corner Mount Occupancy Sensor uses passive infrared (PIR) technology and one of three lenses to detect occupancy in different types of spaces for energy-efficient control of lighting and plug loads. It is a digital sensor, and is part of the NEW wireless Wattstopper Digital Lighting Management (DLM) system.

## OPERATION

The LMPX-600 communicates with the room controller(s) to turn loads on and off based on occupancy. It operates on an included CR123A battery providing a 10+ year lifespan. An installer can create a wireless network via Push-to-Pair, connecting it to other wireless DLM devices in the room (e.g. LMRC-611 wireless dimming room controller or LMBC-650 wireless bridge) drastically reducing installation time and eliminating wiring errors. Default operation is established by Plug n' Go, which automatically configures system components to maximize energy savings. Initially, all occupancy sensors control all loads on the same local network. Each LMPX-600 may be assigned to a specific load; load assignments and load parameters may be changed using Push n' Learn. The LMPX-600 may be reconfigured using one of two options:

1. **DLM Configuration App** available for iOS® or Android®. Simply walk through the on screen prompts to connect and configure wireless DLM devices in the room. Plug n' Go automatic configuration assigns all loads connected to dimming room controllers to the dimming switch upon system startup.
2. **Push-to-Pair** – Press the "config" button on each wireless device in the room to pair them together.

## DIGITAL SETTINGS AND WIRELESS COMMUNICATION

Changes are made at the sensor using the DLM Configuration App that communicates with the sensor via Bluetooth low energy technology. The built-in IPv6 and Bluetooth low energy radio transceivers in the LMPC-600 allows two-way communication for both wireless configuration using the DLM Configuration App and system operation. Time delay and sensitivity can be precisely adjusted and walk through mode can be activated.

## APPLICATIONS

The wireless nature of the LMPX-600 makes it ideal for renovations or any application where quick and easy installation of a lighting control system is desired. LMPX-600 sensors, with different lenses for different spaces, are ideal for high and low ceiling areas including large offices, computer rooms, kindergarten classrooms, aisle-ways, warehouses and open offices where coverage cut-off is desired.

The sensors can detect walking motion throughout an area of approximately 2,000 square feet. The high density lens provides coverage of desktop activity for an area up to 1,000 square feet. The long range and aisle-way lenses detect motion approaching the sensor as far out as 85 to 90 feet and 55 to 60 feet, respectively.

PROJECT

LOCATION/  
TYPE

## FEATURES

- Component of the wireless Digital Lighting Management integrated control system
- Robust and reliable BACnet over IPv6 Network based on open standards & protocols formed automatically with other wireless DLM components
- Multiple options for commissioning: the DLM Configuration App for iOS or Android, Push-to-Pair
- IPv6 wireless standard delivers reliable, long range, low latency wireless communication that is scalable for a single room or entire buildings with thousands of rooms
- Firmware can easily be updated over the air using the DLM Configuration App (which communicates via Bluetooth low energy technology).
- Plug n' Go™ automatic configuration for quick installation and maximum energy savings
- Push n' Learn™ functionality for customization without the need for tools or a PC
- Internal antennas with diversity provide robust signal strength and reliable communication
- Device Validation: Trusted hardware chips prevent any outside devices from being able to connect to the lighting control network.
- Zero touch provisioning: Pre-loaded digital identity and security profile increases system security level.
- Ongoing AES encryption: Communication between devices is protected by AES128 symmetric key encryption
- Backward compatible with wired DLM via wireless bridge (LMBC-650) enabling easy hybrid architecture when wired product functionality is needed
- Device Security: Factory provisioned trusted hardware with Legrand-private certificate chain and signed ECC keypair.
- Sensor coverage tested to NEMA Guide Publication WD 7-2000
- The product meets the materials restrictions of RoHS

## SPECIFICATIONS

- Power Supply: Battery powered, Lithium Ion, CR123A 3V, 1500 mAh (included)
- Connection to DLM Network: Wireless IPv6 Mesh
- Wireless Standards supported:
  - IPv6 (6LoWPAN / 802.15.4 / 2.4GHz), range up to 60 ft.
  - Bluetooth low energy (802.15.4 / 2.4GHz), range up to 30 ft.
- Built-in Antennas: IPv6 and Bluetooth low energy
- Wireless Encryption: AES 128-bit symmetric key
- Device Security: Factory provisioned trusted hardware with Legrand-private certificate chain and signed ECC keypair
- Operating conditions: for indoor use only; 32-104°F (0-40°C); 5-95% RH, non-condensing
- UL and cUL listed
- FCC part 15 compliant
- Five year warranty

## PRODUCT DIMENSIONS

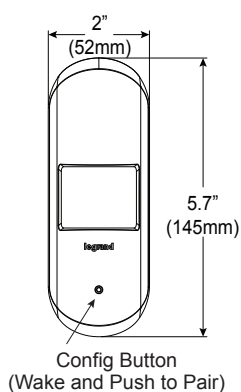

With Plate Mount Attached

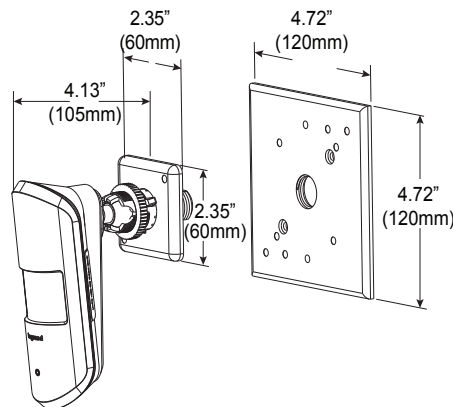

With Ball Mount

## MOUNTING

The LMPX-600 can be mounted using one of three possible methods:

- Mounted to a wall or corner using the included mounting plate
- Mounted directly to a wall, using the included ball mount
- Mounted to a j-box within a wall, using the included ball mount and ball mount plate
- Mounted to a ceiling, using the included ball mount and ball mount plate
- Mounted to a hanging threaded rod, for open ceiling environments, using the included threaded rod adapter

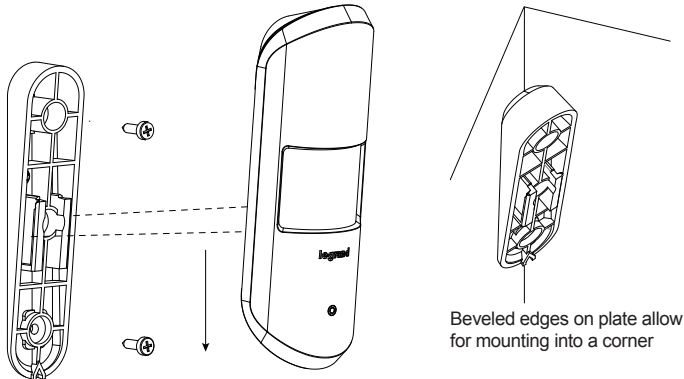

Align the slots of the bracket to the ribs on the back of the sensor. Then slide the unit into the bracket until it is locked in place.

**Wall/Corner Mount**

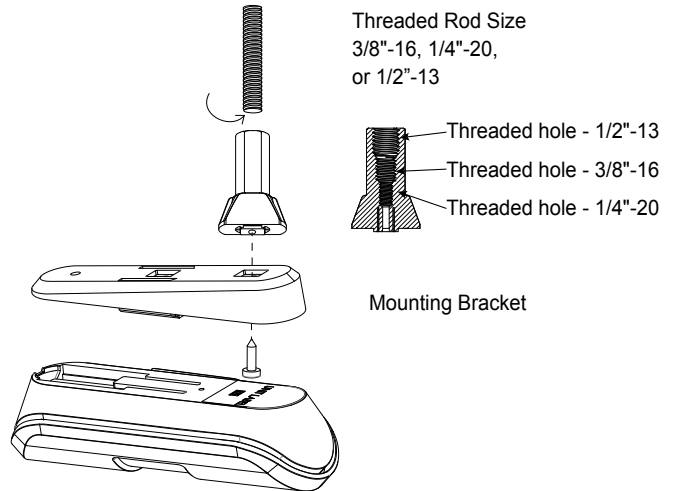

**Threaded Rod Mount**

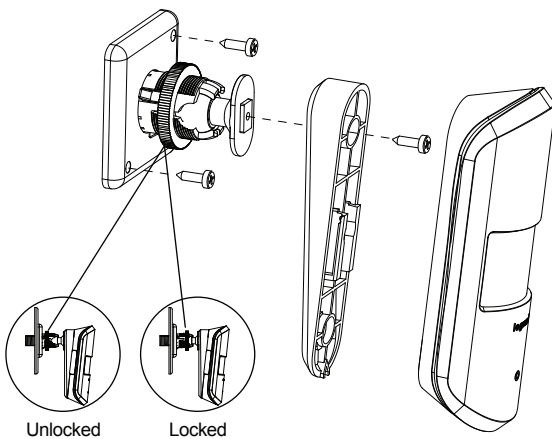

**Ball Mount to Wall**

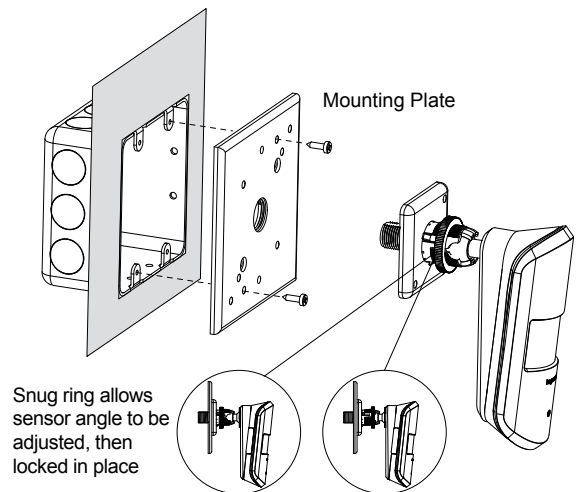

**Ball Mount to J-Box**

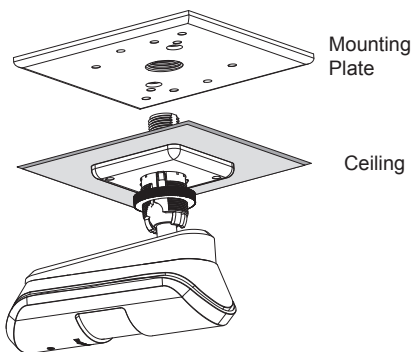

**Ball Mount to Ceiling**

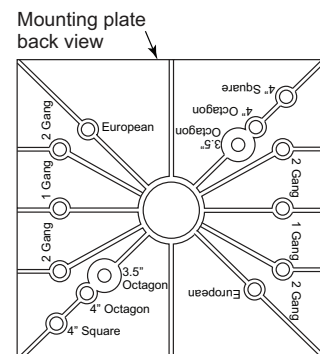

**Mounting plate accommodates different size J-boxes**

## COVERAGE PATTERNS

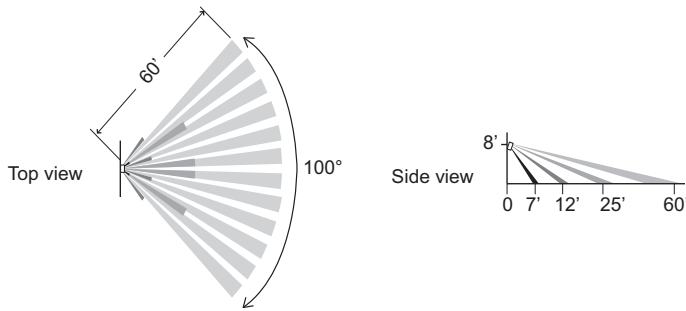

**LMPX-600, wide angle lens**

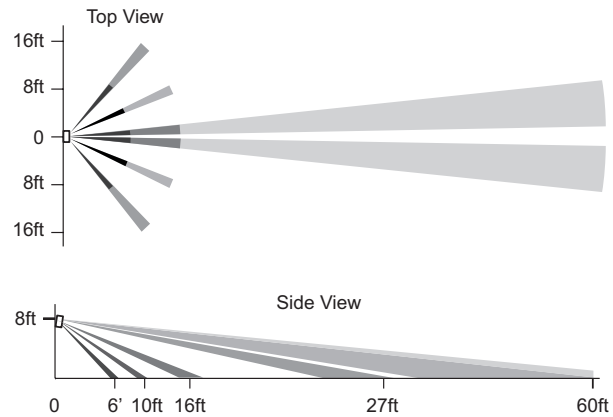

**LMPX-600-1, long range lens**

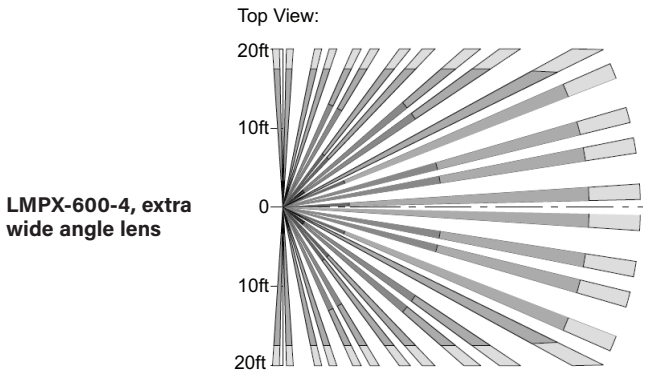

**LMPX-600-4, extra wide angle lens**

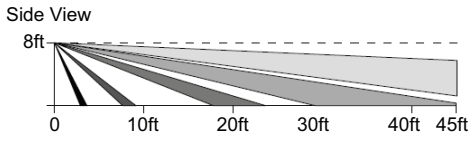

## CONNECTION

### Wireless Room

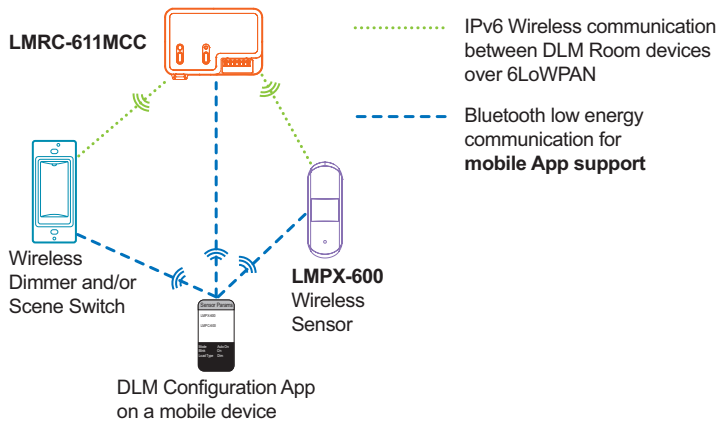

### Hybrid Room (Wired and Wireless Devices)

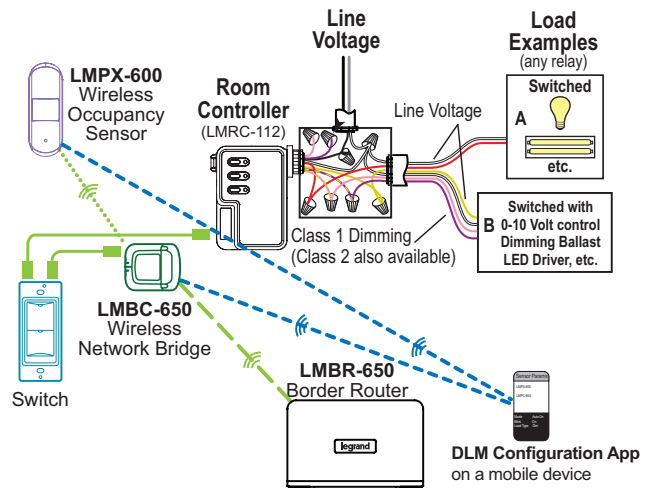

### Distance Recommendations:

- 30' max between LMPX-600 and mobile device
- 60' max between LMPX-600 and room controller or bridge

**Note:** For a single (non-networked) hybrid room, the LMBR-650 is not required.  
**Note:** The DLM Config App can only connect with the LMBC-650 to update firmware or pair devices. You need an LMBR-650 and LMCS to commission a Hybrid room. For a single room, without an LMBR-650, LMCS can connect to the LMBC-650 via the LMCI.

## ORDERING INFORMATION

Catalog #	Description
<input type="checkbox"/> LMPX-600	Wireless Corner Mount PIR Occupancy Sensor, wide angle lens
<input type="checkbox"/> LMPX-600-1	Wireless Corner Mount PIR Occupancy Sensor, long range lens
<input type="checkbox"/> LMPX-600-4	Wireless Corner Mount PIR Occupancy Sensor, extra wide angle lens

The Bluetooth® word mark and logos are registered trademarks owned by the Bluetooth SIG, Inc. and any use of such marks by Wattstopper is under license.

Google Play and the Google Play logo are trademarks of Google Inc.

The Apple logo, iPhone, iPod touch, and iTunes are trademarks of Apple Inc., registered in the U.S. and other countries.